

## Profile

- Max. resolution up to 1  $\mu\text{m}$
- Repeat accuracy  $\pm 0.01\text{ mm}$
- Status LED display
- Works with magnetic band MB500
- Reading distance up to 2 mm

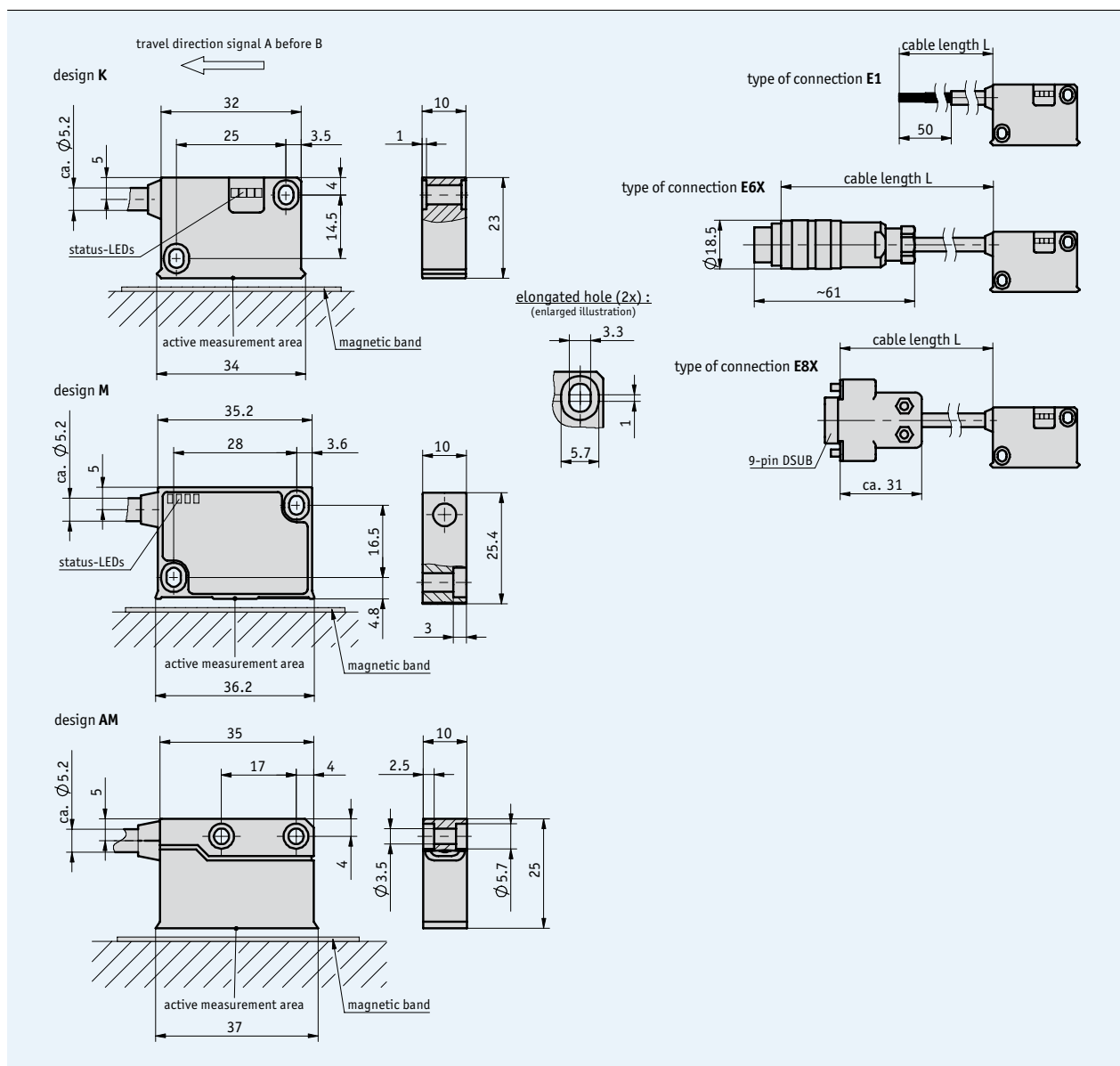

## Mechanical data

Feature	Technical data	Additional information
Scale embodiment	MB500	
System accuracy	$\pm(0.025 + 0.01 \times L)$ mm, L in m	
Repeat accuracy	max. $\pm 0.01$ mm	
Sensor/band reading distance	0.1 ... 2 mm 0.1 ... 1.5 mm	with reference signals O, I with reference signal R
Travel speed	depends on resolution and pulse interval	see table
Housing	plastic black	
Sensor cable	PUR	drag chain-compatible
Operating temperature	-10 ... +70 °C	
Storage temperature	-30 ... +80 °C	
Humidity	100 % rh	condensation permitted
Protection category	IP67	
Vibration resistance	10 g/50 Hz	
Max. measuring length	infinite	

### Travel speed

Resolution (mm)		Travel speed $V_{\text{max}}$ (m/s)									
		0.001	0.005	0.010	0.025	0.050	0.100	0.200	0.320	0.500	0.800
Pulse interval ( $\mu\text{s}$ )	0.001	4.00	3.20	1.60	0.80	0.32	0.20	0.10	0.05	0.03	0.01
	0.005	20.00	16.00	8.00	4.00	1.60	1.00	0.50	0.25	0.13	0.06
	0.010	25.00	25.00	16.00	8.00	3.20	2.00	1.00	0.50	0.25	0.12
	0.025	25.00	25.00	25.00	20.00	8.00	5.00	2.50	1.25	0.63	0.30
	0.050	25.00	25.00	25.00	25.00	16.00	10.00	5.00	2.50	1.25	0.61
Counting frequency (kHz)	0.100	25.00	25.00	25.00	25.00	25.00	20.00	10.00	5.00	2.50	1.21
	0.20	0.25	0.50	1.00	2.50	4.00	8.00	16.00	32.00	66.00	
		1250.00	1000.00	500.00	250.00	100.00	62.50	31.25	15.63	7.81	3.79

## Electrical data

Feature	Technical data	Additional information
Operating voltage	6.5 V DC ... 30 V DC 4.75 V DC ... 6 V DC	reverse-polarity protection on UB no reverse-polarity protection on UB
Current consumption	<20 mA off-load <75 mA loaded	at 24 V
Type of connection	flying leads round connector D-SUB 9-pin	
Output circuit	PP LD (RS422)	
Output signals	A, /A, B, /B, Option: I, /I or R, /R	
Pulse width of reference signal	1 or 4 increments	
Resolution	0.001, 0.005, 0.01, 0.025, 0.05, 0.1 mm	
Interference protection class	3	IEC-61000-6-2
Real-time requirement	real-time signal processing	
Signal level high	>UB - 2.5 V >2.5 V	with PP with LD
Signal level low	<0.8 V	

■ Signal forms

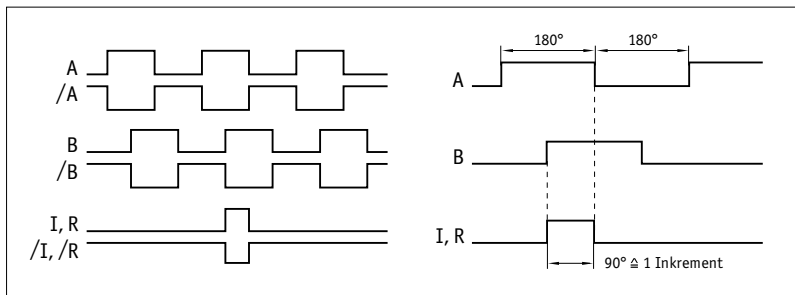

**!** The logical condition of signals A and B is not defined in reference to the index signal I or the reference signal R. It can deviate from the signal form.

**!** Reference or index signal with 4 increments (360°) signal length is only valid from the 5th counting step onwards. A corresponding delay should be taken into consideration after switching on the operating voltage.

■ Pulse interval

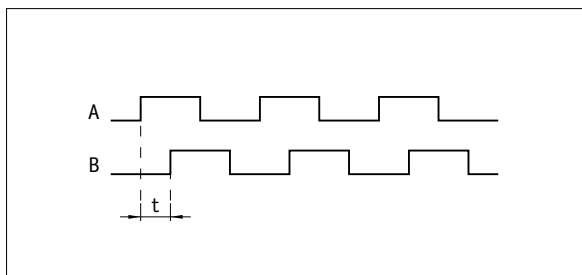

**Example: Pulse interval t = 1 μs**  
(i.e., the downstream unit must be able to process 250 kHz)

$$\text{Formula for counting frequency} = \frac{1}{1 \mu\text{s} \times 4} = 250 \text{ kHz}$$

Pin assignment

■ inverted without index signal

Signal	E1	E6X	E8X
A	red	1	1
B	orange	2	2
+UB	brown	4	4
GND	black	5	5
/A	yellow	6	6
/B	green	7	7
N.C.		3	3, 8, 9

■ inverted with index signal

signal	E1	E6X	E8X
A	red	1	1
B	orange	2	2
I, R	blue	3	3
+UB	brown	4	4
GND	black	5	5
/A	yellow	6	6
/B	green	7	7
/I, /R	violet	8	8
N.C.			9

### Mounting instruction

On systems with reference points on the magnetic band, please ensure the correct alignment of the sensor and band (see diagram).

Reference signal	O, I	R
A, Sensor/band reading distance	max. 2 mm	max. 1.5 mm
B, Lateral offset	max. ±2 mm	max. ±0.5 mm
C, Misalignment	<±3°	<±3°
D, Longitudinal tilt	<±1°	<±1°
E, Lateral tilt	<±3°	<±3°

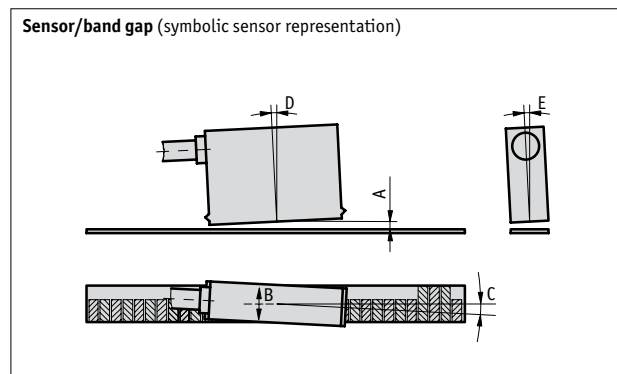

### Order

#### Order table

Feature	Order data	Specifications	Additional information
Operating voltage	10	6.5 ... 30 V DC	
	11	4,75 ... 6 V DC	
Design	K	plastic housing	
	M	metal housing with status LEDs	
	AM	metal housing without status LEDs	
Type of connection	E1	flying leads, 2 m cable	
	E6X	round connector without mating connectors	
	E8X	D-SUB 9-pin without mating connectors	
		cable extensions on request	
Cable length L	...	1 ... 20 m, in steps of 1 m	
		others on request	
Output circuit	PP	push-pull	only operating voltage 10
	LD	line driver	
Reference signal	O	without	
	I	index periodic	
	R	fixed reference	
Resolution	...	0.001, 0.005, 0.010, 0.025, 0.050, 0.1	
Pulse interval in μs	...	0.2, 0.25, 0.5, 1, 2.5, 4, 8, 16, 32, 66	

#### Order code



**Scope of delivery:** MSK5000, User information, Allen fastening screws M3 x 14 mm ISO 4762, lock washers M3 DIN 7980, strain relief for sensor cable, distance gage 0.8 mm

**Additional information:**

Short Description, Technical Details  
Product Overview

Page 46 cont.  
Page 4 cont.