

Distance couplings | General

Definition - distance couplings:

This category comprises several coupling series which can span axial distances up to 6 m of length. The common main characteristic feature of all types is a intermediate pipe resp. a metal bellow part, which is variable in length and can fit exactly the required applications of the customer. In many cases, they can be used as spacer shaft (synchronizing shaft) and can substitute conventional constructions of intermediate

shafts with complicated additional intermediate bearings. Misalignments, especially parallel misalignments, can be compensated to a higher extend.

Further more the stainless material and the easy assembly of all series must be emphasized. A secure, frictional connection with easy operation is given because of the hub design in half-shell version (series WDS, WDE) resp. with sliding hub (series EKZ).

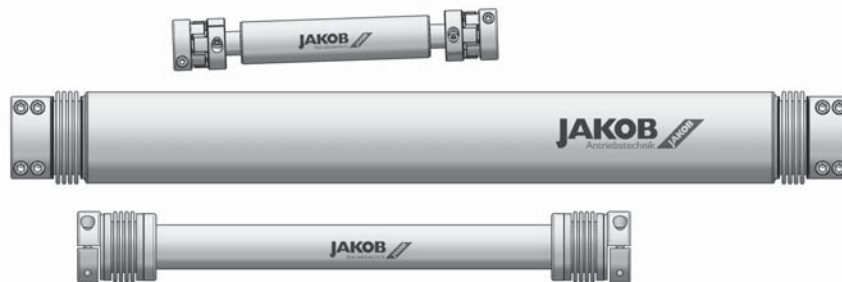

Characteristics – JAKOB-distance couplings:

- /// as connecting shaft without additional intermediate bearing
- /// up to 6 m axial distance
- /// high torsional stiffness // backlash free, exact torque transfer
- /// compensation of displacements
- /// very easy to fit // stainless design // maintenance free
- /// high speed

The customer can chose between three standard series with aluminium intermediate pipe:

Series EKZ

- /// length L = 0,2 - 3 m
- /// 6 sizes up to 700 Nm
- /// T max = 100°C
- /// elastomer spider
- /// plug-in sliding hub
- /// oscillation dampening
- /// costeffective type for medium speed

Series WDE

- /// length L = 0,2 - 3 m
- /// 5 sizes up to 500 Nm
- /// T max = 100°C
- /// metal bellow
- /// integrated cardan joint
- /// costeffective type with reduced operating parameters

Series WDS

- /// length L = 0,2 - 6 m
- /// 7 sizes up to 1600 Nm
- /// T max = 300°C
- /// metal bellow
- /// integrated cardan joint
- /// big pipe diameter for max. speed
- /// high torsional stiffness
- /// pipe connection detachable -> in house production of the pipe is possible

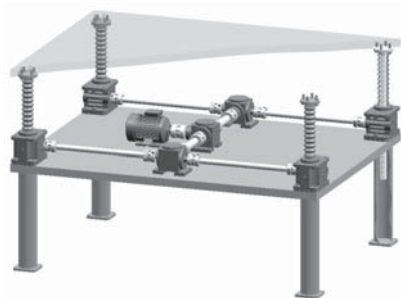

EKZ - coupling for lifting table drive

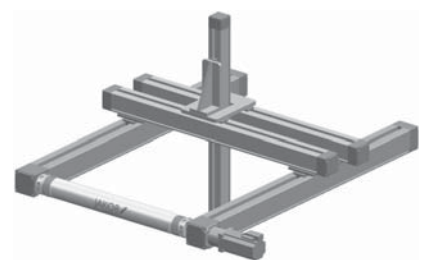

WDS - coupling for multi-axis linear module

Distance couplings I Assembly

Assembly:

The splitted hub-, or the shifting hub design allows for an easy assembly. Further simplification during installation is provided because one half of the split hub is screwed onto the pipe. This allows that the coupling can rest on the two shaft ends. The second half of the split hub can be then mounted to the coupling by screwing it on from below with the specified tightening torque. This feature makes a "one man assembly" possible even with extremely long couplings. During maintenance, the WB coupling can be exchanged without disassembling the drive or output units.

Formula for length determination:

$$L = A + t1 + t2 \quad [\text{mm}]$$

A = shaft separation ± 1
 t = plug in depth ± 1
 (see data sheets)

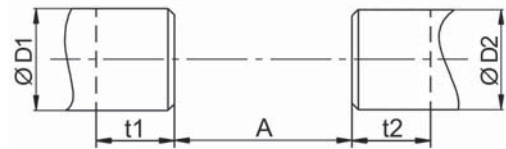

Series EKZ

plug in hub

clamp-connection with shifting seat to pipe end

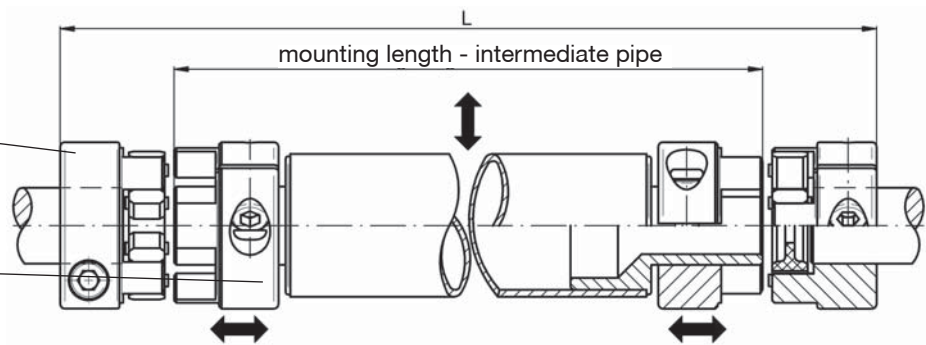

Series WDS

splitted hub design

removeable connection to pipe

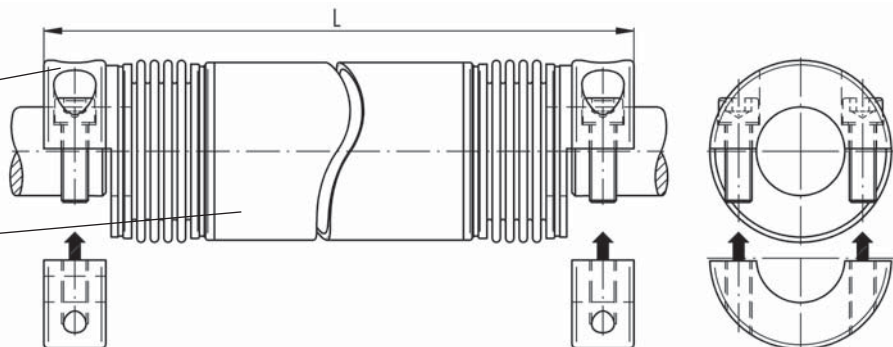

Series WDE

splitted hub design

glued connection to pipe

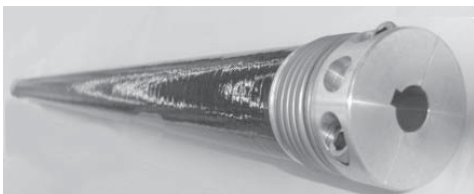
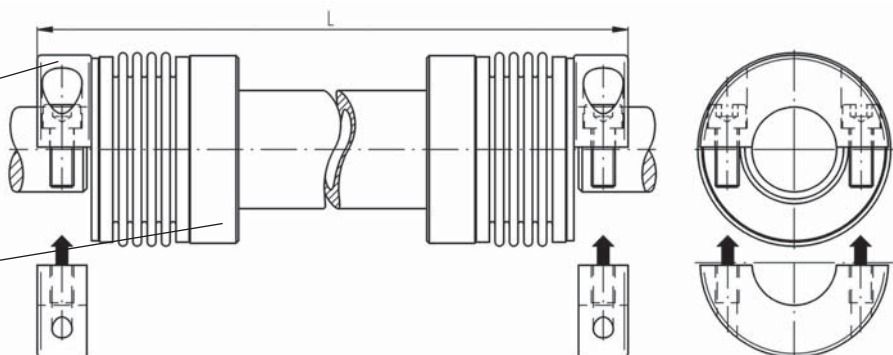

Note: The intermediate pipe can be delivered in different types of material and section thickness, as well as for high speed in straightened and balanced quality. At high speed and con current big pipe length the custom- designed optimized CFK - intermediate pipes will be used. (see Photos above)