

Safety couplings



Directory Safety couplings I Overview

Safety couplings – indirect drives

page



SKB // simple installation with clamping ring hub // for high axial and radial load
// extra ordinary synchronism and quiet running // with integral ball bearing

48



SKY // with conical clamping hub // with integral ball bearing
// small shaft diameters // extra ordinary synchronism and quiet running

49



SKX-L // with slide bearing // with small centric diameter of small size pulleys
// simple installation with clamping ring hub

50



SKG // with conical clamping hub and integral ball bearing
// compact attachment - optimal system integration

51



SKW // easy keyway connection // with integral ballbearing
// cost - effective type

52

Safety couplings – direct drives



SKB-KP // with bellow attachment // simple installation
// with radial clamping hub on both sides

54



SKY-KS // with bellow attachment // small shaft diameters
// with conical clamping hub on both sides // high speed

55



SKB-EK // with elastomere attachment // plug in // simple installation
// with radial clamping hub on both sides

56



SKY-ES // with elastomere attachment // small shaft diameters
// with conical clamping hub on both sides // high speed

57

Safety couplings I General

Definition – Safety couplings:

Due to the constantly increasing automation and dynamics of modern work processes, the devices which protect the complex and expensive units against resulting damages in case of errors are increasing in importance. JAKOB safety couplings reduce expensive machine damages, repairs and down time by acting as torque limiters and overload protection, absolutely reliably. JAKOB safety couplings are the life insurance for your machines, no matter whether the error is due to incorrect operation, programming error, material overload or tool breakage.

JAKOB safety couplings are the result of decades of continuous research and development as well as the experience gained from thousands of different applications worldwide.

Unique design aspects, high quality materials, precision machining of the individual components are some of the factors which make JAKOB couplings one of the leading couplings today. The safety couplings are used in all areas of the machine tool industry, ranging from critical servo drive applications to overload protection in conveyor systems.

Output characteristics – JAKOB Safety couplings:

- ✓ optimum overload and crash protection
- ✓ backlash free, exact torque transfer
- ✓ stepless disengagement torque adjustment
- ✓ fixed point reengagement (360° synchronised position)
- ✓ automatic re-engaging ✓ optional activate function
- ✓ degressive spring characteristic ✓ precise disengagement function
- ✓ excellent dynamic functional characteristics
- ✓ low moments of inertia ✓ high speed
- ✓ large selection of types (modular system)
- ✓ integral fitting of pulleys or gear wheels
- ✓ stop-signal (emergency- stop) by using proximity switch

Application examples:

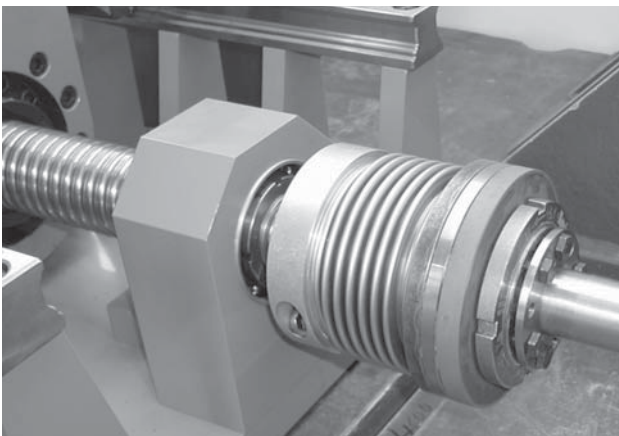

Collision protection of a drive spindle with safety coupling series SKB-K with bellow attachment

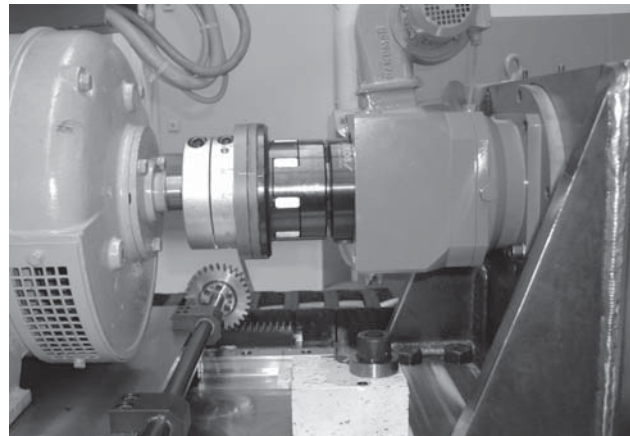

Safety coupling series SKB-E with elastomer attachment for overload protection of a planetary gearbox.

Safety couplings I Modular system

Due to the constantly increasing automation and dynamics of modern work processes, the devices which protect the complex and expensive units against resulting damages in case of errors are increasing in importance. JAKOB safety couplings reduce expensive machine damages, repairs and down time by acting as torque limiters and overload protection, absolutely reliably. JAKOB safety couplings are the life insurance for your machines, no matter whether the error is due to incorrect operation, programming error, material overload or tool breakage.

The constitutive options- and coordination are the necessary disengagement torque, the required torsional stiffness, the existing shaft diameter, the fitting condition as well as other operating parameters like temperature and shaft displacement.

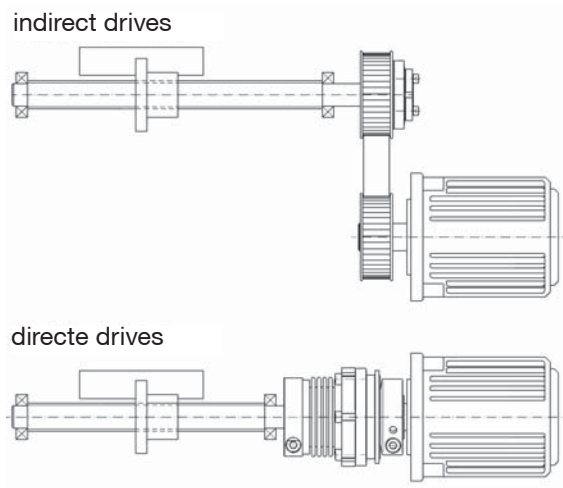

Definition-Safety couplings:

Safety mechanism

2 Nm - 3.000 Nm

attachments

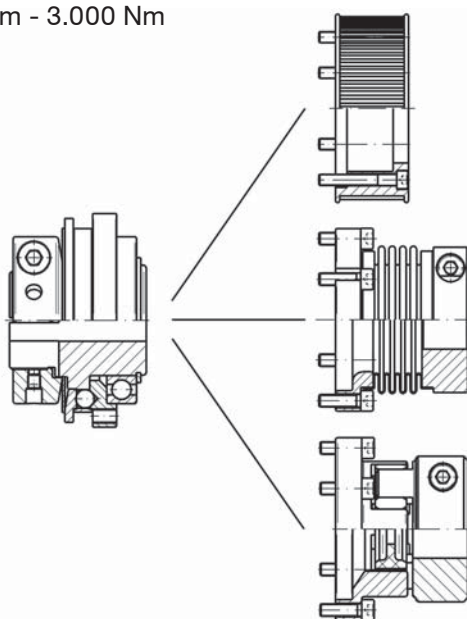

- /// pulleys
- /// gears
- /// Flanges

- /// metal bellows
 - torsional stiff
 - all- steel- version
 - high operating temperatures
 - variable length

- /// elastomer spider
 - oscillation dampening
 - plugin, electrically insulating
 - $T_{max} \leq 120^{\circ}C$

Series

SK

SKB-K
SKY-K

SKB-E
SKY-E

Notice:

- /// To reduce the wear of the safety coupling mechanism the drive should be stopped as soon as possible after disengagement. The switching signal of the limit switch can be used for this (emergency- OFF function) purpose
- /// In vertical drive axis the slide or the table can drop upon disengagement of the safety coupling due to its own weight and also the low residual torque of the safety coupling. To counter this effect it is suggested that either a compensating weight or an additional brake be provided.
- /// During the coupling selection the linear measuring system (positioning) must also be considered. When fitting an encoder on the drive motor a torsionally stiff coupling should be used to get the best result.
- /// For high speed application, please select types SKY or SKY-ES, because of their rotary symmetric design. Nominal speed up to 4000 min^{-1} are possible on request.
- /// The safety coupling is maintenance free under normal operating conditions.
- /// For mounting instructions and explanations about the shaft - hub - connection, please look at >Servo couplings< page 4-9.

Safety couplings I Technical and function principle

JAKOB safety couplings are designed as nominal break points or as overload protection in a direct or indirect drive train. The heart of the safety coupling is a highly precise, sturdy declutching mechanism with steel balls as spring loaded positive locking elements. The drive torque is guided into the centrally arranged hub via a frictional, backlash free radial clamping hub or conical bush connection. The hub is designed as a ball cage and serves for fitting the flange ring and the thrust plate with the cup springs press the balls over a thrust plate into hardened detents (calotte) of the flange ring. In normal operation the drive torque is transferred, backlash free, into the flange ring. For the further transfer of the torque and speed, a choice of compensation elements (metal bellows, elastomer spider, membrane hubs), a gear or pulley or an appropriate connection flange is fitted to the flange ring. If the set disengagement torque is exceeded in the case of a crash or collision, the flange ring turns in relation to the cage hub and the balls are abruptly pushed out of the detents. The drive train is cut-off within a few milliseconds..

The backlash free ball locking mechanism

The **preloading principal** of the hardened and polished steel balls between the ball cage, the hub, and the detents of the flange ring ensure a **backlash free torque** and angular motion transfer with high torsional stiffness. The mechanism is effective **in reverse direction** also i.e. for clockwise or counter-clockwise operation.

The degressive spring characteristic

The function of the safety coupling is influenced substantially by the cup springs, developed specifically for this application. Due to its operation in **degressive characteristic range**, the spring force drops with increasing spring stroke (switching path), whereby **the torque drops immediately** on response. With conventional spring loaded torque limiters on the other hand, springs are stressed even further and the spring force as well the disengagement torque increase considerably before the actual disengagement takes place, leading to additional damage, This results in undesirable functional characteristics between response and disengagement.

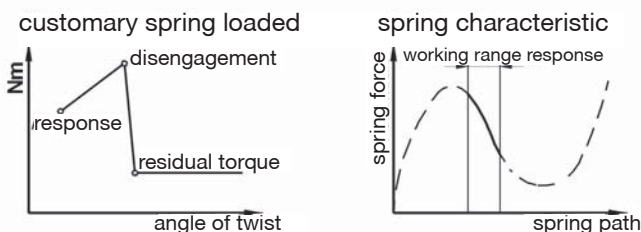

JAKOB- Safety coupling

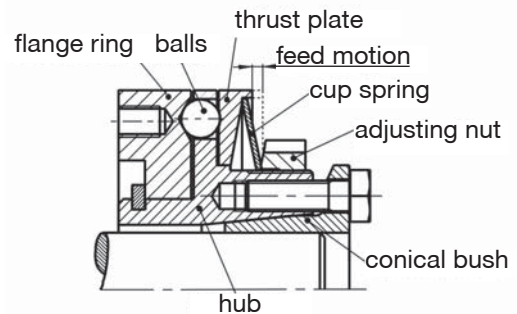
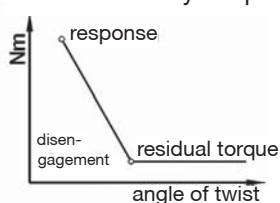

The axial stroke of the indexing plate can be used with a proximity or mechanical limit switch for the immediate stop (emergency-OFF) of the drive.

The dynamic disengagement characteristics

JAKOB safety clutches are distinguished by their excellent dynamic disengagement characteristics. The reason for this is the **degressive spring characteristic**, as well as the **minimised masses** (ball and indexing plate), which must be accelerated, axially during disengagement. The product of mass and acceleration ($F=m \cdot a$) results in a force which must be added to the spring force. In conventional couplings where large masses have to be moved, the static disengagement torque

The re - engaging

The balls, the cage bores and detents are distributed asymmetric on the circumference, so that every 360° only one **synchronized location** is possible. Until then the balls ratchet over with a low **residual torque** (max. 5% of TN). After elimination of the breakdown cause, the coupling re-engages during operation at low speed (< 60 r.p.m) **automatically** again into the **synchronized position** and is ready for function. The relocation time for the reference point location is reduced considerably due to the synchronous reengagement.

The release mechanism

The clutch series SBE and SKD are equipped with an additional control mechanism, which prevents a reengaging i.e. allows the balls to ratched over until standstill. The drive train is thereby put in a "stand by" state and the residual torque reduced to a minimum. The reengagement takes place automatically in either direction upon reversal of the rotation direction at low speeds as and when the reference position is reached.

The Labyrinth box

At the SKB, SKY, SKX-L and SKW series is the locking mechanism protected against penetration with dirt and washing out of lubricants by a special labyrinth box.

Safety couplings I Adjusting the disengagement torque

The disengagement torque is generally between approximately 40% and 100% of the nominal torque of the coupling and is steplessly adjustable. If the customer does not specify a setting value, the **setting is done at the maximum torque** (nominal torque). The set, static disengagement torque can be adjusted (on the machine) if necessary at a later date by turning the adjusting nut with a pin wrench. Adjusting nuts are provided with a user friendly scale; the disengagement torque, and the reference marks for T_{min} and T_{max}, are engraved on the face side of the adjusting nut to facilitate setting. Greater disengagement torques greater than T_{max} are possible (on request); through this results a stronger wear of the disengagement mechanic.

Caution:

Due to the degressive spring characteristic within the setting range, a turning back (counter clockwise) of the adjusting nut means an increase, or a turning in clockwise direction means a reduction of the disengagement torque (See direction arrow at clamping nut)!

Series SKG/SKY/SKW

Setting marking for disengagement torque:

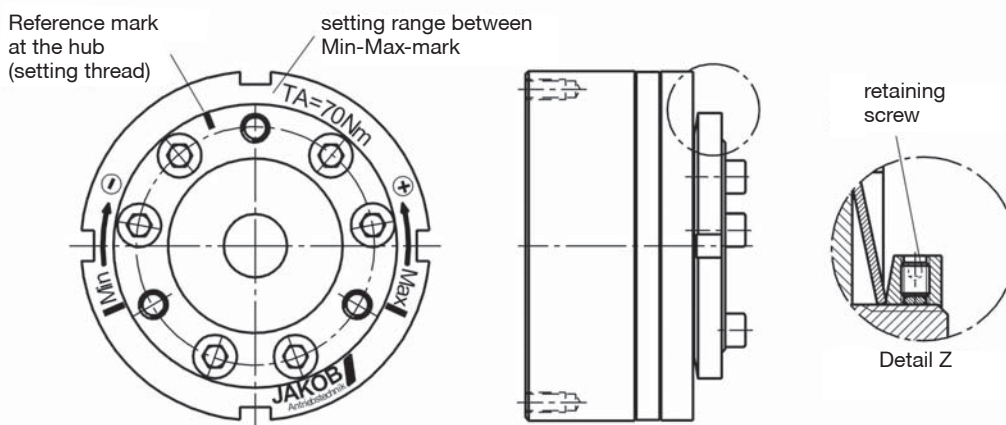

Unscrew retaining screw (see detail Z) completely; turn adjusting nut with pin wrench; after adjustment secure the adjustment nut against turning by drilling and tightening the self tapping screw.

Series SKB/SKX-L

Setting scale for disengagement torque:

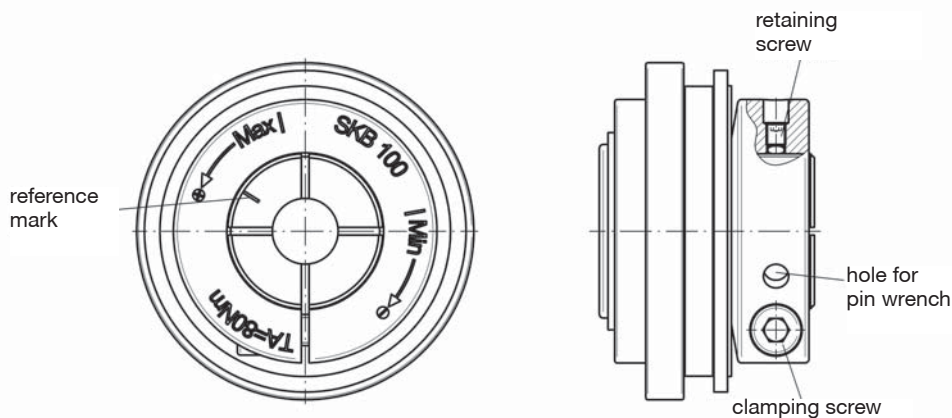

Release retaining screw. turn adjusting nut with pin wrench (note reference mark); tightening retaining screw on hub after setting the required disengagement torque. Setting can be done by turning the hub with scale till the torque value to be set is in line with the reference mark. in mounted status the clamping screw must be released and after setting the disengagement torque it has to be fastened again.

Safety couplings I *for indirect drives*

- ✓ for the attachment of toothed belt pulleys, gear wheels, chain wheels, flanges and so on
- ✓ with integrated ball bearing or sliding bearing - optimal constructional adjustment
- ✓ frictional shaft-hub-connection with conical clamping bush resp. conical clamping ring

For overload protection resp. as collision protection for indirect drives, JAKOB's standard program presents series SKB, SKY, SKW and SKG with integrated ball bearing, as well as series SKX-L with integrated sliding bearing. They enable the adjustment of toothed belt pulleys, gear wheels or other units to the coupling flange rings with a concentricity- resp. run-out exactness of a few hundredth of millimeters. During normal operation, the bearings must take up the radial and axial forces and transfer them to the drive, resp. output shaft, only during uncoupling there is a relative rotating movement between flange ring and hub for a short time. The chosen torque is transferred backlash free and frictionally from the shaft to the coupling hub by a conical clamping ring resp. a conical clamping bush. As the SKB coupling can be used for big pulleys and pinions because of the reference diameter of the fastening threads, the SKX-L series is made for longer attachment parts with small centric diameter. The series SKG with its integrated ball bearing provides a good alternative for very compact constructional solutions. In this cases, the coupling body can almost completely be fit into the pulley with the result, that the forces can be led almost centrally to the bearing. Furthermore, the clamping ring is located at the inside, at the side of the shaft, and therefore a subsequent mounting (modification) is possible, even when available space is limited. Other safety coupling series for indirect drives, such as e.g. series SKM with separate sliding bearing or Series SKD with blocking mechanism can be delivered upon special request.

Series SKB

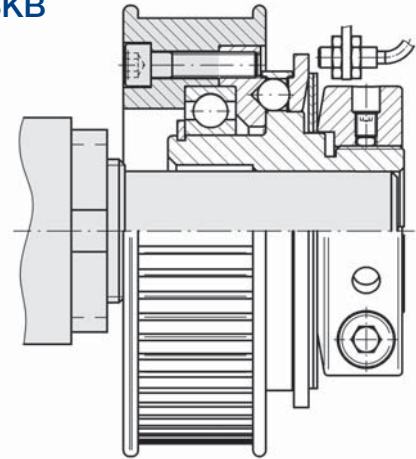

Series SKY

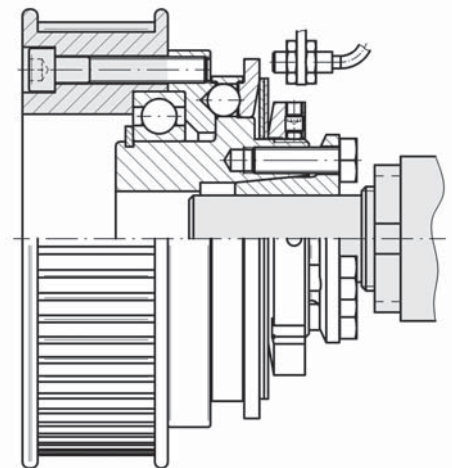

Series SKX-L

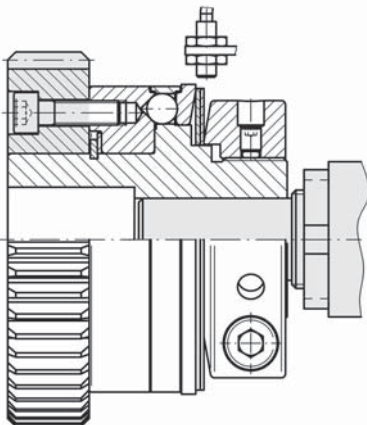

Series SKW

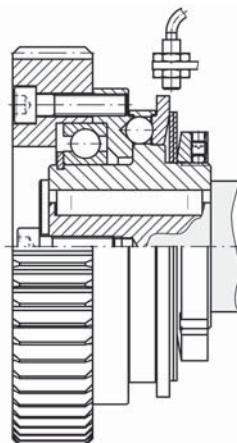

Series SKG

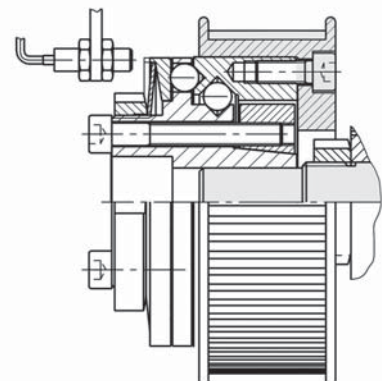

Safety coupling I Series SKB for indirect drives

- /// simple installation with clamping ring hub // with integral ball bearing
- /// for high axial and radial load // extra ordinary synchronism and quiet running
- /// alternative in corrosion-resistant design

Technical data:

SKB size	setting range		moment of inertia [10 ⁻³ kgm ²]	mass approx. [kg]	tightening torque of screw „i“ [Nm]	max. radial load F _R [N]	bore diameters øD		
	disengagement torque T _{KA} [Nm]						prebored	min	max
6	2	- 6	0,09	0,36	M 5 - [10]	5.000	6	6	16
12	6	- 12						8	16
15	8	- 15	0,36	0,80	M 6 - [18]	8.000	10	10	25,4
30	13	- 30						12	25,4
45	22	- 45	1,10	1,50	M 8 - [40]	9.500	17	14	25,4
60	25	- 60						18	35
100	40	- 100	4,2	3,3	M 10 - [80]	23.000	21	18	35
150	60	- 150						24	35
230	80	- 230	12,2	6,2	M 14 - [220]	30.000	27	24	44
330	130	- 330						32	44
500	200	- 500	76	20	2x M16 - [290]	50.000	38	28	58
800	350	- 800						40	58
1000	500	- 1000	76	20	2x M16 - [290]	50.000	38	42	100
2000	800	- 2000						48	100
3000	1500	- 3000						60	100

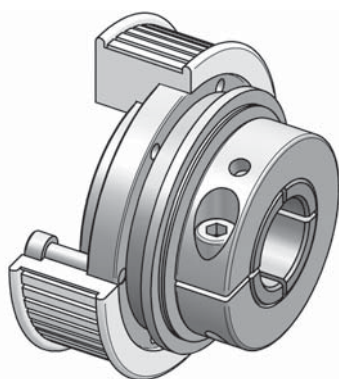

Material: heat-treated steel

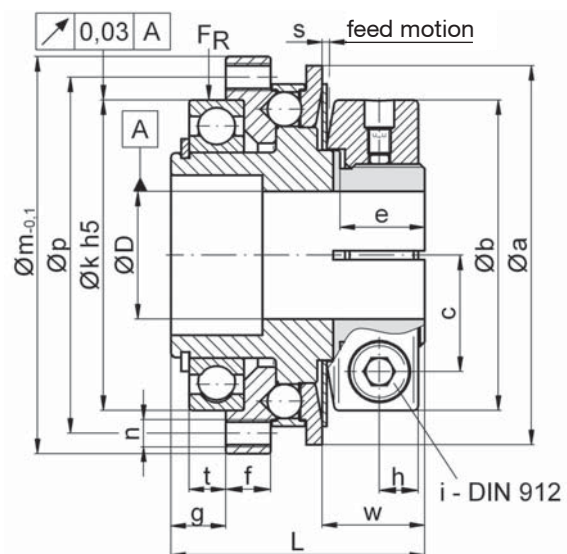

Dimensions [mm]: length dimensions according to DIN ISO 2768 cH

SKB	Øa	(Øa*)	Øb	c	e	f	g	h	Øk ^{h5}	Øm	Øp	L	n	s	t	w
6/12	48	(42)	38,5	13,5	13	8	9,8	6	42	52	47	41	6xM3	0,9	7	15,8
15/30/45	66	(60)	53	19,5	15	9	11,5	7,5	55	69	62	48	6xM4	1,2	8	18,5
60/100/150	83	(76)	68	25,5	18,5	9	12	8,5	68	87	78	55,5	6xM6	1,6	8	22,4
230/330	109	(104)	87	32	21	14	16,5	10,5	90	113	102	71,5	6xM8	1,8	12	25,6
500/800	132	-	115	42	30	15	17	13,5	110	136	124	87,5	8xM8	2,5	12	37
1000-3000	185	-	172	69	76	19	28	17/30	140	181	165	142±2	12xM10	3,7	22,5	77

* Notice: Smaller outer diameters of the thrust plate are possible (see values in brackets).

Ordering example: SKB 30 - D = Ø 24^{H7} - T_{KA} = 25 Nm
 SKB 230 - corrosion resistant - D = Ø 35^{G6} - T_{KA} = 200 Nm

Safety coupling I Series SKY for indirect drives

- /// with conical clamping hub // with integral ball bearing
- /// for high axial and radial load // extra ordinary synchronism and quiet running
- /// alternative in corrosion-resistant design

Technical data:

SKY size	setting range disengagement torque T_{KA} [Nm]		moment of inertia $[10^{-3}kgm^2]$	mass approx. [kg]	tightening torque of screws 6x i [Nm]	max. radial load F_R [N]	borediameters $\varnothing D$		
	min	max					prebored	min	max
6	2	- 6	0,08	0,30	M 3 - DIN 912 - [2]	5.000	-	5	11,5
12	6	- 12					5	11,5	
15	8	- 15	0,31	0,65	M 4 - DIN 912 - [4]	8.000	8	9	17
30	13	- 30					9	17	
45	22	- 45	0,95	1,3	M 6 - DIN 933 - [14]	9.500	11	10	17
60	25	- 60					12	24	
100	40	- 100	3,8	2,9	M 6 - DIN 933 - [14]	23.000	17	12	24
150	60	- 150					14	24	
230	80	- 230	10	5,1	M 8 - DIN 933 - [35]	30.000	25	18	35
330	130	- 330					22	35	
500	200	- 500	53	15	M 12 - DIN 933 - [115]	50.000	38	28	44
800	350	- 800					30	44	
1000	500	- 1000	70	70	M 12 - DIN 933 - [115]	50.000	40	40	70
2000	800	- 2000					41	70	
3000	1500	- 3000					48	70	

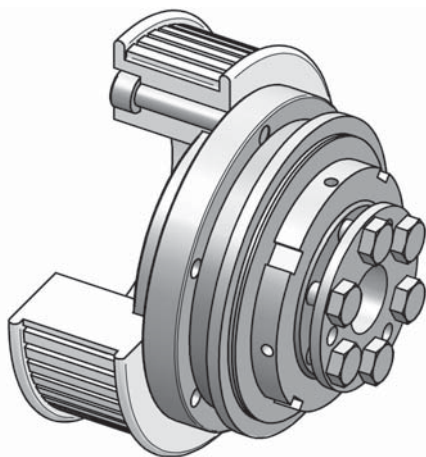

Material: heat-treated steel

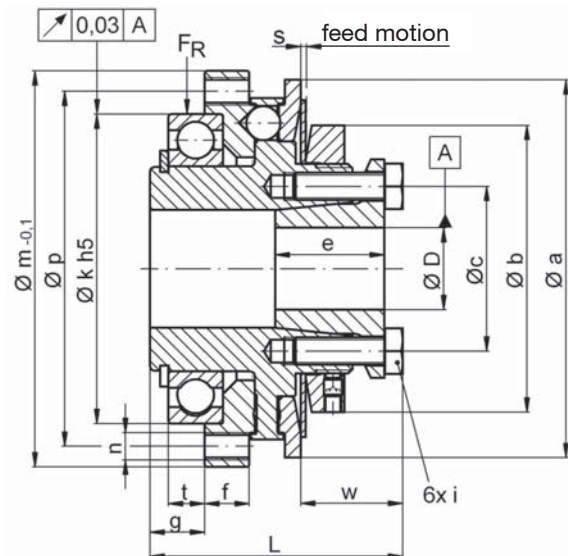

Dimensions [mm]: length dimensions according to DIN ISO 2768 cH

SKY	$\varnothing a$	$(\varnothing a^*)$	$\varnothing b$	$\varnothing c$	e	f	g	$\varnothing k^{h5}$	$\varnothing m$	$\varnothing p$	L	n	s	t	w
6/12	48	(42)	33	19	15	8	9,8	42	52	47	39	6xM3	0,9	7	13,8
15/30/45	66	(60)	45	27	18	9	11,5	55	69	62	47,5	6xM4	1,2	8	18,1
60/100/150	83	(76)	63	36,2	24	9	12	68	87	78	55,5	6xM6	1,6	8	22,4
230/330	109	(104)	84	50	27	14	16,5	90	113	102	70	6xM8	1,8	12	24
500/800	132	-	105	62	32	15	17	110	136	124	84	8xM8	2,5	12	33,4
1000-3000	185	-	168	98	45	16	28	140	181	165	130	12xM10	3,7	22,5	64,5

* Notice: Smaller outer diameters of the thrust plate are possible (see values in brackets).

Ordering example: SKY 60 - D = $\varnothing 22^{G6}$ - $T_{KA} = 40$ Nm
 SKY 150 - corrosion resistant - D = $\varnothing 22^{G6}$ - $T_{KA} = 120$ Nm

Safety coupling I Series SKX-L for indirect drives

- with longer bearing journal for integrated slide bearing
- simple installation with clamping ring hub
- with small centric diameter of small size pulleys, gear wheels

Technical data:

SKX-L size	setting range disengagement torque T_{KA} [Nm]	moment of inertia [10^{-3}kgm^2]	mass approx. [kg]	tightening torque of screws i [Nm]	prebored	bore diameters $\varnothing D$ min	max
6	2 - 6	0,05	0,25	M 5 - [10]	6	6	16
12	6 - 12					8	16
15	8 - 15	0,25	0,65	M 6 - [18]	10	10	25,4
30	13 - 30					12	25,4
45	22 - 45					14	25,4
60	25 - 60	0,95	1,5	M 8 - [40]	17	18	35
100	40 - 100					18	35
150	60 - 150					24	35
230	80 - 230	3,34	3	M 10 - [80]	21	24	42
330	130 - 330					32	42
500	200 - 500	10,70	6	M 14 - [220]	27	28	58
800	350 - 800					40	58

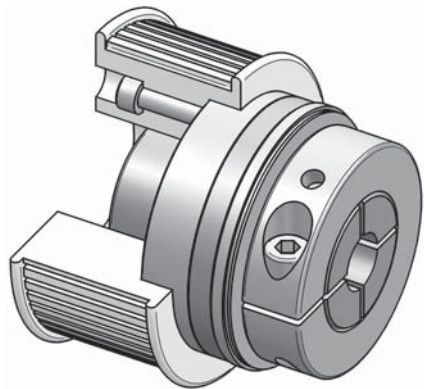

Material: heat-treated steel
bearing seat: nitro carbonized

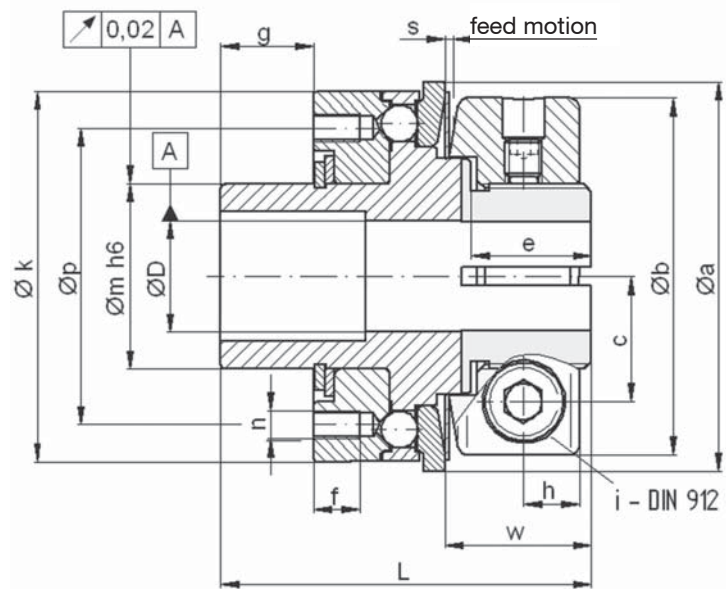

Dimensions [mm]: length dimensions according to DIN ISO 2768 cH

SKX-L	$\varnothing a$	($\varnothing a^*$)	$\varnothing b$	c	e	f	g	h	$\varnothing k$	$\varnothing m^{h6}$	$\varnothing p$	L	6xn	s	w
6/12	42	(48)	38,5	13,5	13	5	10	6	40	20	32	46	M3	0,9	15,8
15/30/45	60	(66)	53	19,5	15	7	15	7,5	58	30	46	52	M4	1,2	18,6
60/100/150	76	(83)	68	25,5	18,5	9	20	8,5	75	42	62	69	M6	1,6	22,4
230/330	104	(109)	87	32	21	12	25	10,5	98	50	74	84	M8	1,8	26,7
500/800	132	-	115	42	30	14	30	13,5	120	65	92	104	M10	2,5	37

Note: * bigger outer diameters of the thrust plate are possible (see values in brackets).

** alternativ bearing length „g“ are possible on request; please check if a plain bearing bush is required.

Ordering example: SKX-L 150 - D = $\varnothing 28^{H7}$ - $T_{KA} = 120 \text{ Nm}$

Safety coupling I Series SKG *for indirect drives*

- /// with integral ball bearing // with conical clamping hub
- /// compact attachment - optimal system integration

Technical data:

SKG size	setting range disengagement torque T_{KA} [Nm]		moment of inertia [10^{-3} kgm ²]	mass approx. [kg]	tightening torque of screws i [Nm]		bore diameters $\varnothing D$ min max	
4	2	- 4	0,2	0,5				
9	4	- 9	0,2	0,5	M 4	- [4]	12	18
18	9	- 18	0,2	0,5				
23	9	- 23	0,7	1,1				
35	18	- 35	0,7	1,1	M 5	- [8]	18	25,5
75	25	- 75	0,7	1,1				
100	50	- 100	1,8	1,9	M 6	- [12]	22	39
170	65	- 170	3	2,4				
270	100	- 270	10,4	5	M 8	- [35]	29	44
550	200	- 550	10,7	5,3				

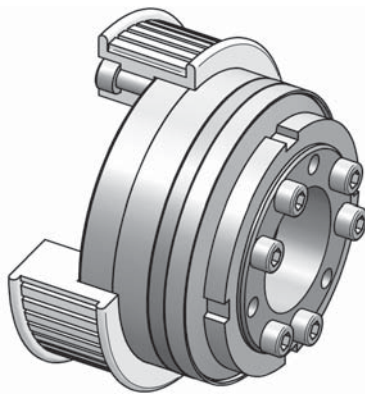

Material: *heat-treated steel*

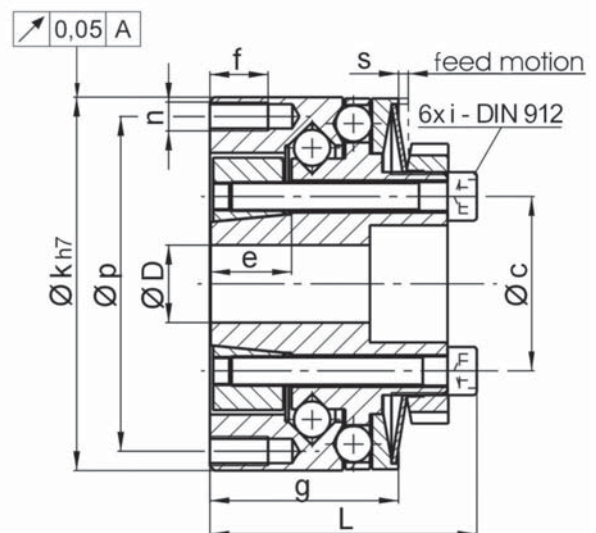

Dimensions [mm]: length dimensions according to DIN ISO 2768 cH

SKG	$\varnothing c$	e	f	g	$\varnothing k_{h7}$	L	n	$\varnothing p$	s
4	27	11	8	27,3	60	40	4x M 4	53	1
9	27	11	8	27,3	60	40	4x M 4	53	1
18	27	11	8	27,9	60	40	4x M 4	53	1
23	37	17	12	39	77	54	4x M 6	69	1,4
35	37	17	12	39	77	54	4x M 6	69	1,4
75	37	17	12	39	77	54	4x M 6	69	1,4
100	54	17	10	36,5	92	55	4x M 6	83	1,4
170	54	17	12	51	105	66	4x M 6	94	1,7
270	66	26	15	63,5	135	85	4x M 6	120	2,2
550	66	26	15	63,5	135	85	4x M 6	120	2,2

Ordering example: SKG 170 - 28^{H7} - $T_A = 140$ Nm

Safety coupling I Series SKW for indirect drives

- ✓ cost-effective type ✓ easy keyway connection
- ✓ with integrated ballbearing for high axial and radial load

Technical data:

SKW Size	setting range disengagement torque T_{KA} [Nm]		moment of inertia [10^{-3}kgm^2]	mass approx. [kg]	max. radial load F_R [N]	n	borediameters $\varnothing D$	
	min	max					min	max
6	2	- 6	0,08	0,28	5.000	6 x M3	6	12
12	6	- 12					6	12
15	8	- 15	0,3	0,63	8.000	6 x M4	8	22
30	13	- 30					10	22
45	22	- 45					10	22
60	25	- 60	0,91	1,25	9.500	6 x M6	11	32
100	40	- 100					13	32
150	60	- 150					16	32
230	80	- 230	3,70	2,80	23.000	6 x M8	18	38
330	130	- 330					21	38
500	200	- 500	9,25	4,80	30.000	8 x M8	26	55
800	350	- 800					38	55
1000	500	- 1000	52	15,5	50.000	12 x M10	39	90
2000	800	- 2000					52	90
3000	1500	- 3000					66	90

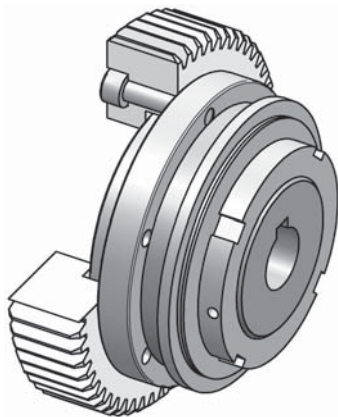

Material: heat-treated steel

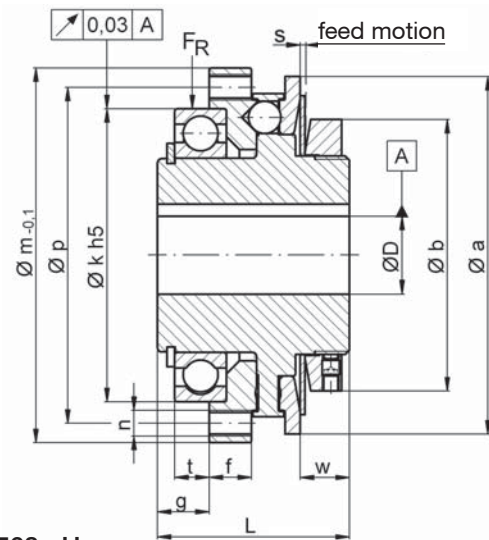

Dimensions [mm]: length dimensions according to DIN ISO 2768 cH

SKW	$\varnothing a$	($\varnothing a^*$)	$\varnothing b$	f	g	$\varnothing k^{h5}$	$\varnothing m$	$\varnothing p$	L	s	t	w
6/12	48	(42)	33	8	9,8	42	52	47	31	0,9	7	5,8
15/30/45	66	(60)	45	9	11,5	55	69	62	38	1,2	8	8,6
60/100/150	83	(76)	63	9	12	68	87	78	44,5	1,6	8	11,4
230/330	109	(104)	84	14	16,5	90	113	102	59,5	1,8	12	13,7
500/800	132	-	105	15	17	110	136	124	68,5	2,5	12	18,1
1000 -3000	185	-	168	19	28	140	181	165	106	3,7	22,5	40,4

* Notice: Smaller outer diameters of the thrust plate are possible (see values in brackets).

Ordering example: SKW 500 - D = $\varnothing 44G6$ - PFN 12 P9 x 3,3 - $T_{KA} = 450 \text{ Nm}$

Safety couplings I *for direct drives*

- ✓ optimum overload and crash protection for direct drives
- ✓ with coupling attachment - system construction cit with numerous variants
- ✓ simple installation, frictional shaft-hub connection
- ✓ kompakt design ✓ low moment of inertia

Series SKB-KP / SKY-KS with bellow attachmentment

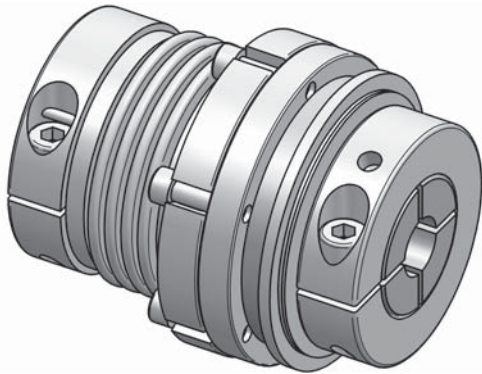

Series SKB-EK / SKY-ES with elastomer attachmentment

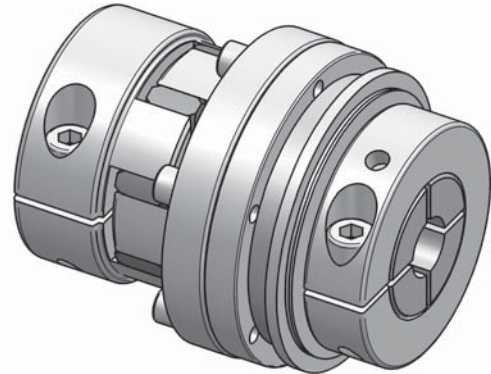

The Safety couplings series SKB-K and SKB-E are a combination since decades approved and optimized JAKOB-disengagement mechanic with a coupling element for balancing from misalignment between drive- und output shaft. From a large program can diverse types with metal bellow- or elastomer couplings be selected. During the specific main feature from metal bellows are very high torsional stiffness and low restoring forces, are the elastomer couplings by robustness, excellent oscillation dampening and the plug in fitting characterized. Based on the screw fitting between coupling element and safety part is at case of damage or at change of technical operating parameters a exchange of the coupling attachment everytime possible.

Following Safty Couplings series for direct drives are available:

- Series SKB-KP -> with 4-corrugation metal bellow / bellowside with easy to fit radial clamping hub
- Series SKY-KS -> with 4-corrugation bellow / bellowside with conical bushing for small shaft diameters
- Series SKB-EK -> with elastomer spider - 98 ShoreA / couplingside with plug in, radial clamping hub
- Series SKY-ES -> with elastomer spider - 98 ShoreA / couplingside with plug in, conical hub

Note: Safety couplings Series SKB with clamping hub - Series SKY with conical bush.

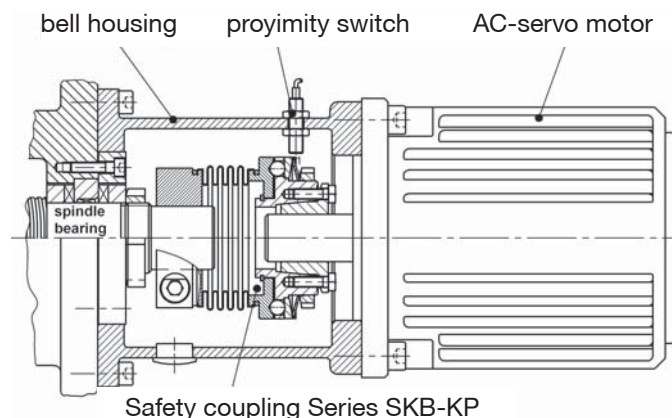

Safety coupling I Series SKB-EK for direct drives

// with elastomer attachment for direct drives // with radial clamping hub on both sides
 // plug in // flexible // backlash free // oscillation dampening

Technical data:

SKB -EK size	setting range disengagement torque T_{KA} [Nm]	moment of inertia [10^{-3}kgm^2]	mass approx. [kg]	torsional stiffness [Nm/arcmin]	max. shaft dis- placement [mm]		tightening torque of screws		$\varnothing D1$		$\varnothing D2$	
					axial \pm	lateral	„f“ [Nm]	„i“ [Nm]	min	max	min	max
6	2 - 6								8	20	6	16
12	6 - 12	0,13	0,44	0,24	0,5	0,1	M5[8]	M5[10]	8	20	8	16
15	8 - 15								12	32	10	25,4
30	13 - 30	0,5	1	0,61	0,5	0,1	M6[14]	M6[18]	12	32	12	25,4
45	22 - 45								14	32	14	25,4
60	25 - 60								16	38	18	35
100	40 - 100	1,5	2	1,05	1	0,1	M8[35]	M8[40]	19	38	18	35
150	60 - 150								22	38	24	35
230	80 - 230	5,6	4,2	2,0	1	0,12	M12[115]	M10[80]	24	43	24	42
330	130 - 330								32	43	32	42
500	200 - 500	17,0	8,6	8,0	1	0,15	M14[185]	M14[220]	30	70	28	58
800	350 - 800								42	70	40	58
1000	500 - 1000	79,0	19,5	12	1	0,1	M14[185]	M16[290]	48	70	42	100

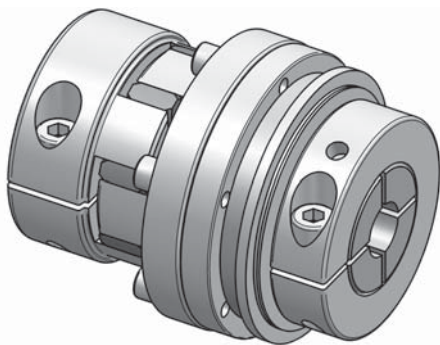

Material: safety part: heat treated steel
 clamping hub: high tensile aluminium
 elastomer spider: Polyurethane – 98 Shore-A
 screws: nickel plated

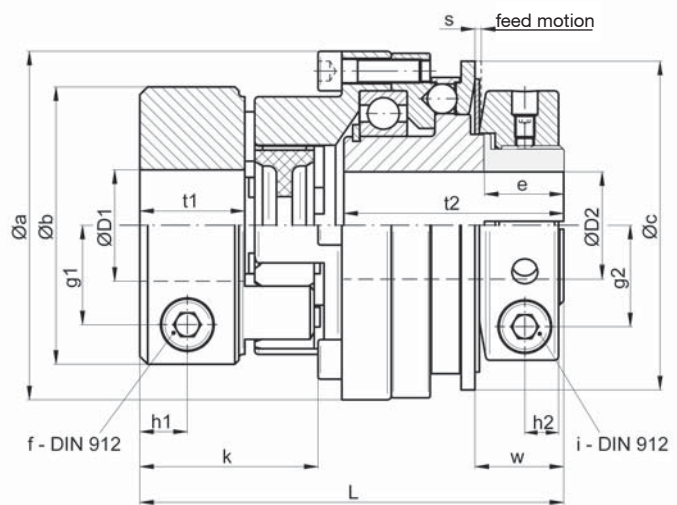

Dimensions [mm]: length dimensions according to DIN ISO 2768 cH

SKB-EK	$\varnothing a$	$\varnothing b$	$\varnothing c$	e	g1	g2	h1	h2	k*	L \pm 1	s	t1	t2	w
6/12	52,5	40	48	14	13	13,5	8	6	33	77	0,9	17	41	16
15/30/45	69	55	66	16	20	19,5	10	7,5	39	91,5	1,2	21	48	18,5
60/100/150	88	70	83	20	25	25,5	12	8,5	45	107	1,6	26,5	55,5	22
230/330	115	85	109	23	29	32	14	10,5	54	134	1,8	31	72	26,5
500/800	137	120	132	32	44	42	18	13,5	71	167,5	2,5	38	87,5	37
1000	181	120	185	74	44	69	18	17/30	72	204	3,7	38	89	74

* **Note:** other shore-hardness of elastomere spider are possible on request
 coupling side with conical hub see series SKB-ES

Ordering example: SKB-EK 45 - $D1 = \varnothing 28^{G7}$ - $D2 = \varnothing 24^{H7}$ - $T_{KA} = 35 \text{ Nm}$

Safety coupling I Series SKY-ES for direct drives

- /// with elastomer attachment for direct drives // with conical clamping hub
- /// elastomer coupling with conical hub // plug in, backlash free, flexible, robust, oscillation dampening

Technical data:

SKY -ES size	setting range		moment of inertia [10 ⁻³ kgm ²]	mass approx. [kg]	torsional stiffness [Nm/arcmin]	max. shaft dis- placement [mm]		tightening torque of screws		ø D1		ø D2	
	disengagement torque T _{KA} [Nm]					axial ±	lateral	„f“ [Nm]	„i“ [Nm]	min	max	min	max
6	2	- 6	0,13	0,5	0,24	0,5	0,1	6xM4[4]	DIN912/M3[2]	9	19	5	11,5
12	6	- 12								9	19	5	11,5
15	8	- 15	0,5	1,0	0,6	0,5	0,1	4xM5[8]	DIN912/M4[4]	12	26	9	17
30	13	- 30								12	26	9	17
45	22	- 45								12	26	10	17
60	25	- 60	1,4	1,9	1,1	1	0,1	8xM5[8]	DIN933/M6[18]	12	36	12	24
100	40	- 100								12	36	12	24
150	60	- 150								14	36	14	24
230	80	- 230	5,5	4,3	2	1	0,12	4xM8[35]	DIN933/M6[18]	19	40	18	35
330	130	- 330								19	40	22	35
500	200	- 500	18,5	8,8	8	1	0,15	4xM12[115]	DIN933/M8[35]	25	60	28	44
800	350	- 800								28	60	30	44
1000	500	- 1000	57	16	12	1	0,1	4xM12[115]	DIN933/M12[115]	48	60	40	70

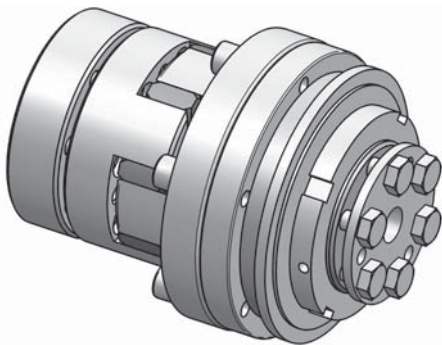

Material: safety part: heat treated steel
 hub: high tensile aluminium
 clamping ring: heat treated steel
 elastomer spider: Polyurethane – 98 Shore-A
 screws: nickel plated

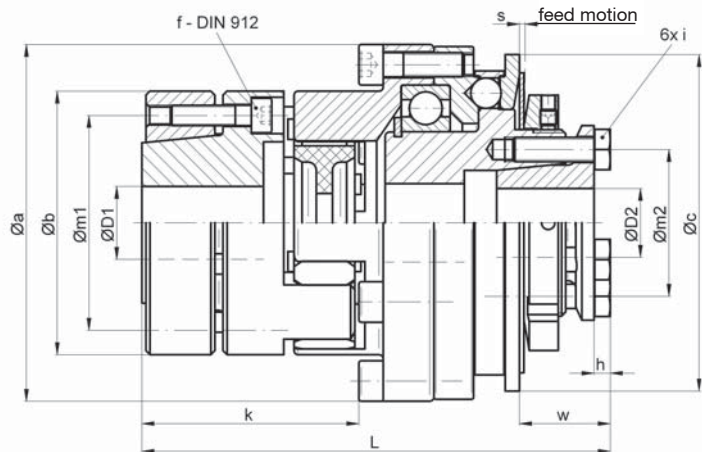

Dimensions [mm]: length dimensions according to DIN ISO 2768 cH

SKY-ES	Øa	Øb	Øc	h	k	L±1	Øm1	Øm2	s	t1	t2	w
6/12	52,5	40	48	3	41	83	31	19	0,9	21	15	14
15/30/45	69	55	66	4	48	100	43	27	1,2	25	18	18
60/100/150	88	65	83	4	53,5	115,5	53	36	1,6	30	24	22
230/330	115	80	109	4	68	145,5	64	50	1,8	40	27	24
500/800	137	120	132	5,3	94	187	96	62	2,5	54	32	33
1000	181	120	185	7,5	95	218	96	98	3,7	54	45	64

Ordering example: SKY-ES 230 - D1 = 33^{H7} - D2 = Ø 28^{H7} - T_{KA} = 200 Nm

Safety couplings I further types

Series

- /// high clamping forces
- /// for smaller shaft diameters
- /// however more difficult assembly
- /// with ES-hub blind fitting possible
- /// dimensions on request
or rather see homepage:
www.jakobantriebstechnik.de

SKB -KS with conical clamping hub

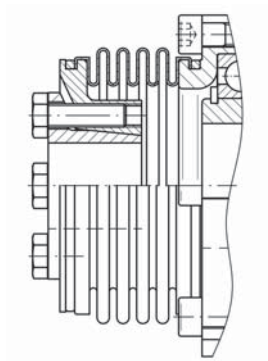

SKB -ES with conical clamping hub

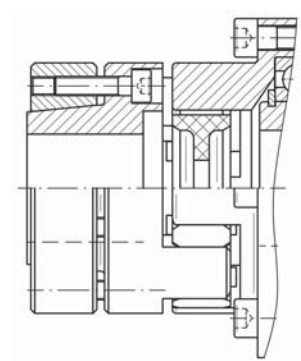

Series SKD/SBE with special blocking mechanis

- /// minimal residual torque
- /// re-engaging only by reverse rotation
- /// with seperate sliding bearing (series SKD)
or with bellow attachment (series SBE)
- /// 10 sizes from 4 up to 1.500 Nm

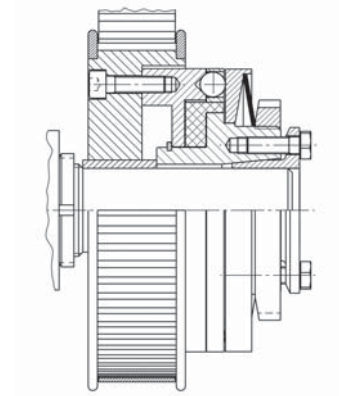
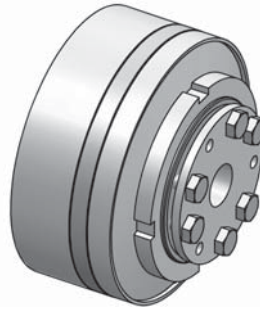

Series SKY with conical bush at bearing side with bearing arrange in tandem

- /// for overlength width toothed belt or
gearwheels
- /// for highest radial loading
- /// compact mounting onto short shaft
- /// dimensions on request

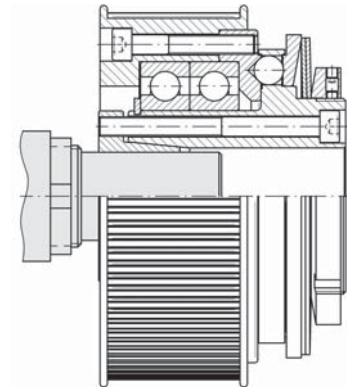
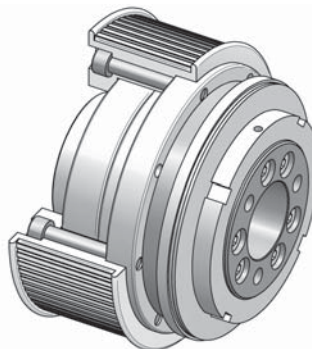

Special series

- /// customized hub versions
and dimensions
- /// operating speeds up to 8.000 rpm
- /// special or stainless steel design
- /// special re-engaging functions,
(e.g. for vertical drive axis)

-> please contact JAKOB

Product overview | JAKOB clamping elements

Power clamping nut Series MCA

- /// 4 sizes up to 200 kN
- /// blind hole thread upto M 64
- /// thread protected
- /// centered operation
- /// compact design



Power clamping nut Series MDA

- /// 2 sizes up to 150 kN
- /// trough hole thread upto M 48
- /// for variable clamping edges
- /// unlimited clamping stroke



Hydraulic clamping nut Series HM

- /// maximum clamping forces over 2000 kN
- /// thread larger than Ø 500 possible
- /// multi hub system withspring feedback and oil affiliation
- /// high hydraulic pressure (800 bar) without medium losing



Power clamping screw Series SC

- /// 5 sizes upto 250 kN
- /// wedge clamping mechanism
- /// high clamping forces
- /// low tightening torque
- /// maximum operation safety

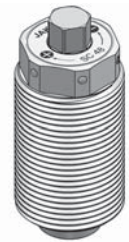

Spring clamping cylinder Series ZSF Spring clamping cylinder Series ZDF

- /// numerous sizes up to 350 kN
- /// mechanical clamping
- /// hydraulic relasing
- /// high operation safety
- /// leakproof, robust, economical
- /// temperature range: -30°C to +100°C
- /// fitting position in any direction

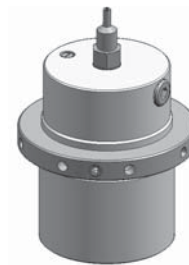

spring clamping cylinder
Series ZSF (pulling)



spring clamping cylinder
Series ZDF (pushing)

Power clamping screws mechanisc type: Series MSP/MSPD hydraulic type: Series HSP

- /// nominal clamping forces bis 1200 kN
- /// maximum operation safety
- /// large power clamping hub
- /// simple operation and fitting
- /// very large clamping forces at low tightenig torques

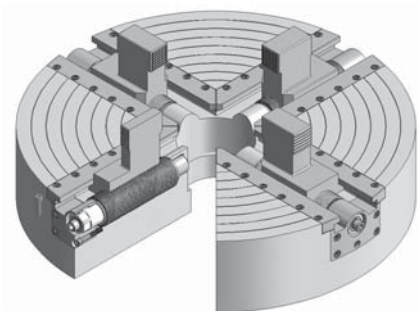

➔ Please ask for JAKOB-clamping elements-catalogue.

So you find us

from direction
Aschaffenburg
A3/A45

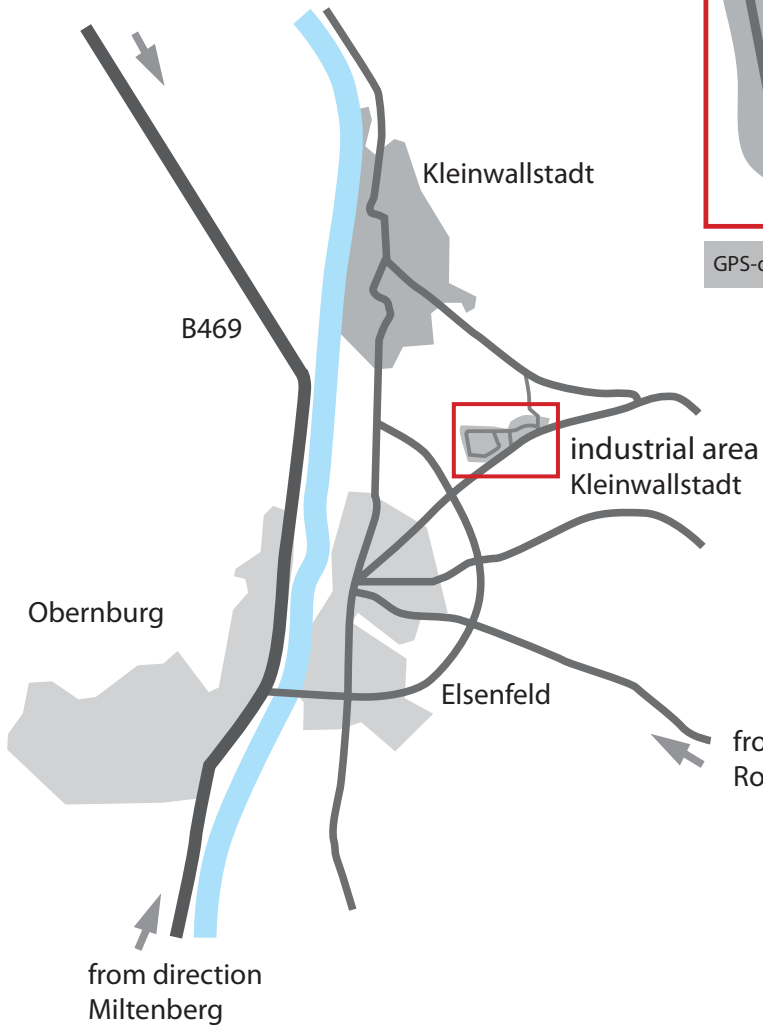

industrial area Kleinwallstadt



GPS-dates: latitude : 49.85587, longitude: 9.17977



Daimler Ring 42, Industriegebiet
D-63839 Kleinwallstadt
Telefon +49(0)6022 2208-0
Telefax +49(0)6022 2208-22
Internet www.jakobantriebstechnik.de
E-Mail info@jakobantriebstechnik.de



OTT-Jakob Spanntechnik GmbH
Industriestr. 3-7 · 87663 Lenggenwang
Fon: (+49) 83 64 98210 · Fax: (+49) 83 64 982110
info@ott-jakob.de · www.ott-jakob.de



T+S-Jakob GmbH & Co. KG
Ressestr. 6 · 87459 Pfronten
Fon: (+49) 8363 9125 0 · Fax: (+49) 8363 9125 49
info@ts-jakob.de · www.ts-jakob.de



ALLMATIC-Jakob Spannsysteme GmbH
Jägermühle 10 · 87647 Unterthingau
Fon: (+49) 83 77 929 0 · Fax: (+49) 83 77 929 380
info@allmatic.de · www.allmatic.de



JAKOB Antriebstechnik GmbH
Daimler Ring 42 · 63839 Kleinwallstadt
Fon: (+49) 60 22 22080 · Fax: (+49) 60 22 220822
info@jakobantriebstechnik.de
www.jakobantriebstechnik.de



GPA-Jakob Pressenautomation GmbH
Greschbachstr. 15 · 76229 Karlsruhe
Fon: (+49) 721 62020 · Fax: (+49) 721 6202222
info@gpa-jakob.de · www.gpa-jakob.de



OPTIMA Spanntechnik GmbH
Postfach 52 · 57584 Scheuerfeld
Fon: (+49) 2741 9789 0 · Fax: (+49) 2741 978910
info@optima-spanntechnik.de · www.optima-spanntechnik.de



JAKOB Vakuumtechnik GmbH
Daimler Ring 42 · 63839 Kleinwallstadt
Fon: (+49) 60 22 220825 · Fax: (+49) 60 22 220846
info@jakobvakuumtechnik.de · www.jakobvakuumtechnik.de