

NSK Linear Guides™

Roller Guide RA Series

A roller guide series employing advanced analysis technology offers super-high load capacity and rigidity.

The latest series is now available in the random matching of rails and roller slides, which includes random matching with preload for higher accuracy and rigidity, allowing the users to purchase rails and roller slides in single unit quantities.

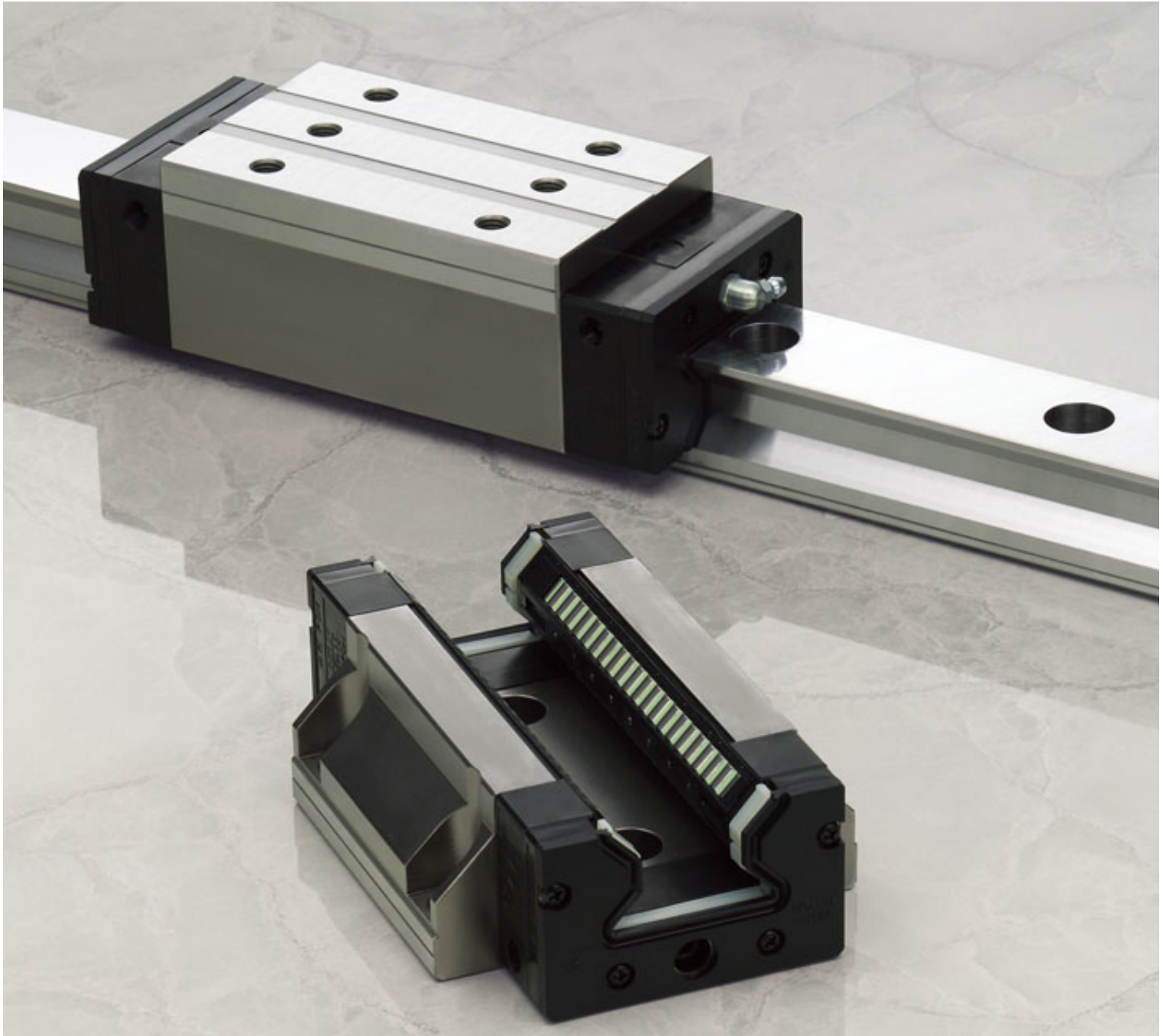

The fruits of comprehensive technology of NSK. RA series roller guides handle a diversity of applications

The RA series of roller guides is the product of a combination of NSK's extensive experience in roller bearings and linear guide technologies. The result is an optimal design that takes full advantage of NSK's unique expertise to realize super-high load capacity, rigidity and motion accuracy, plus smooth motion. Capable of handling a variety of applications, the RA series supports high machine performance.

RA series features support high machine performance

Super-long Life

Super-high load capacity

NSK has realized super-high load capacity, now the highest performance in the world, and achieved unprecedented operating life.

Maintenance-free

Installing an NSK K1™ lubrication unit assures long-term, maintenance-free operation.

Highly dust-proof

The high performance seals as standard equipment completely block the entry of foreign matter and maintain primary performance over the long term.

Contribution to High-precision Manufacturing

Super-high rigidity

Super-high rigidity provides high-precision manufacturing.

Super-high motion accuracy

Coupled with NSK's unique design approach, the vibration caused by roller passage has been substantially reduced. This will greatly contribute to improve machining quality.

Smooth motion

The installation of a retaining piece achieves smooth motion, resulting in stable positioning accuracy.

The RA series is available in eight models:

RA15, 20, 25, 30, 35, 45, 55 and 65.

Used in Many Fields

Complete series

Series includes a full lineup from small to large, including low-profile sizes. You can choose the model according to the application.

Interchangeable mounting dimensions

Outside dimensions and mounting dimensions conform to standard dimensions for the market, so RA series roller guides can be used without having to alter machine design. (See page 11 for mounting surface dimensions)

Low friction

Uses rollers for rolling elements to hold down dynamic friction.

Optimal Design

NSK executed a comprehensive, detailed performance simulation of roller guides by integrating its analysis technology and the tribology technology that the company had been developing over many years. Down to the dimensions and shapes of component details, we have attained an optimal design completely.

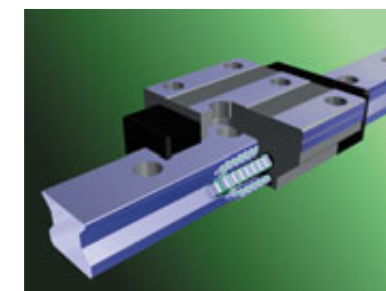

Smooth motion by use of retaining pieces

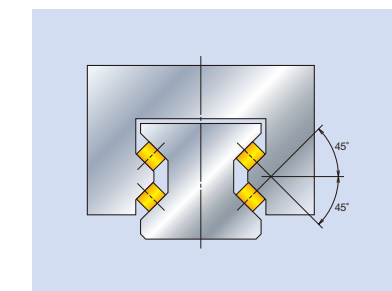

Balanced four-directional iso-load specifications

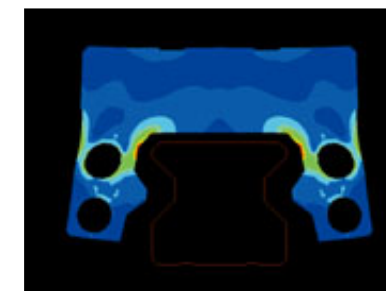

Example of roller slide deformation analysis

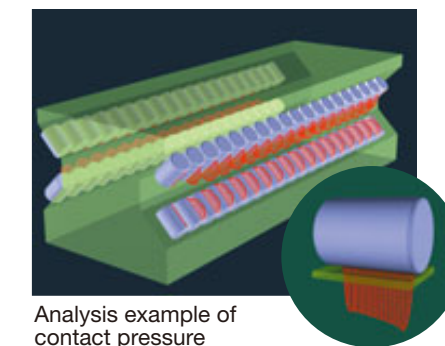

Analysis example of contact pressure distribution of rollers



Now available in random matching type.

RA25, 30, 35, 45, 55, 65

Available in Single Unit Quantities

Accuracy compatibility

The roller guides of random matching type comply with the assembly specification of the precision grade of P6.

Random matching with preload

The random combinations of roller slide and rail provide the constant rigidity with an adequate preload. (Preload code: Z3)

Available in single unit quantities

The rails and roller slides can be selected and purchased in single unit quantities.

Features

1. Super-high load capacity

By installing rollers that are the largest possible diameter and length within the existing standard cross-section dimension in a rational layout based on analysis technology, we have realized the world's highest load capacity*, far superior to conventional roller guides. Super-long life is achieved and impact load can be sufficiently handled.

* Compared with products of the same size, as of September 1, 2003, researched by NSK.

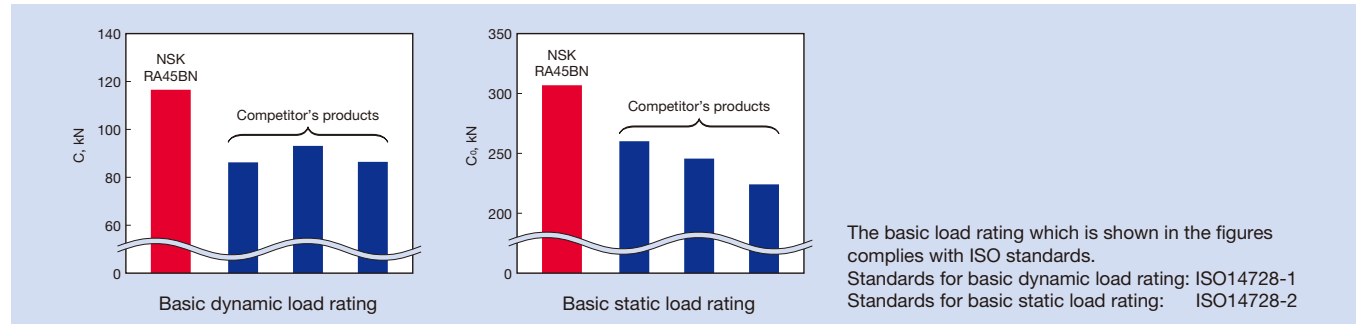

2. Super-high rigidity

Using NSK's advanced analysis technology, we pursued a complete, optimal design, down to the detailed shape of roller slides and rails, thereby realizing super-high rigidity superior to that of competitor's roller guides.

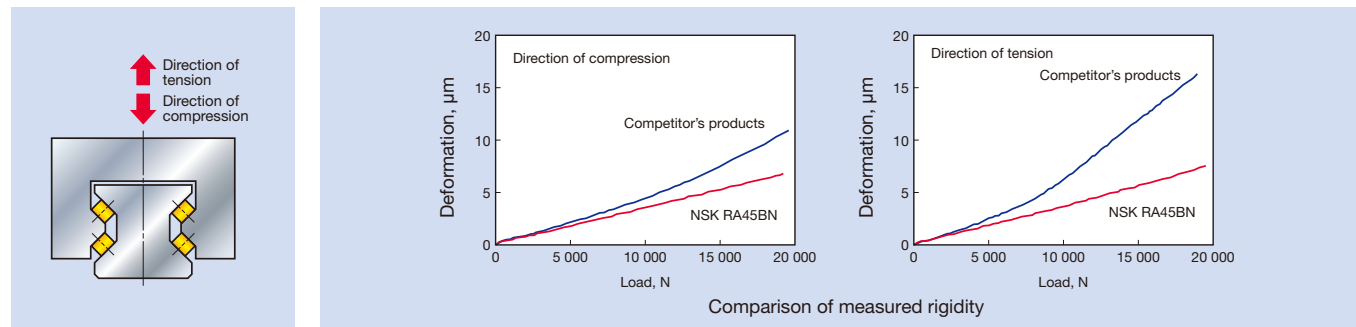

3. Super-high motion accuracy

NSK has developed its own unique method of simulating rolling element passage vibration and method of designing optimal roller slide specifications for damping roller passage vibration. These developments have dramatically enhanced roller slide motion accuracy for the RA series.

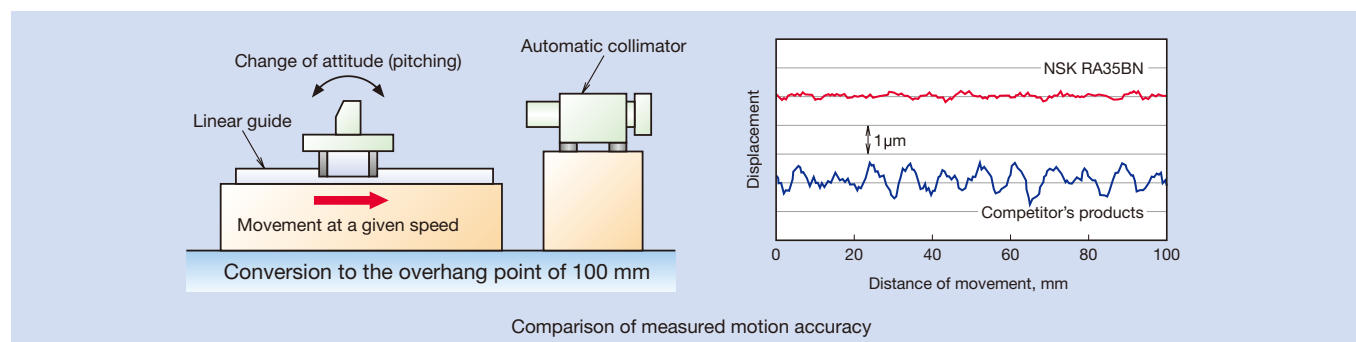

4. Mounting dimensions compatibility

The outer and mounting dimensions of RA series are based on market standards. RA series can be replaced without altering equipment design. (See page 11 for mounting surface dimensions)

5. Smooth motion

Installing a retaining piece between rollers and restraining the skew peculiar to roller bearings achieve smooth motion. The reduction of friction variation provides stable tracking in the complicated trajectory control.

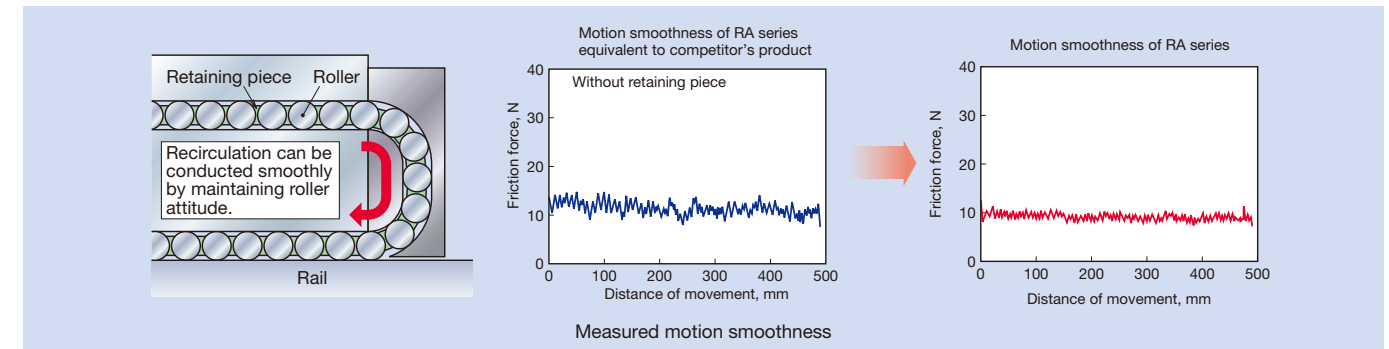

6. Low friction

Using rollers for rolling elements helps minimize dynamic friction.

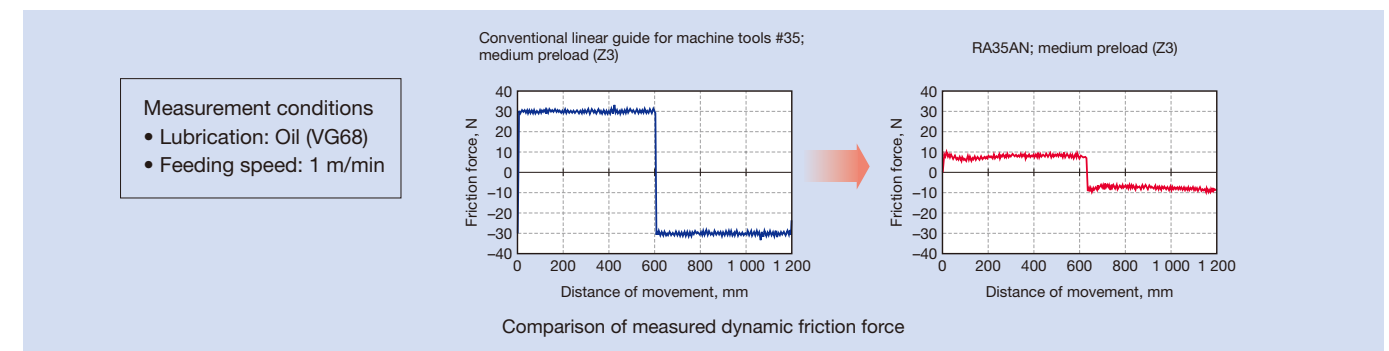

7. Highly dust-proof and maintenance-free operation

Roller slides include high performance seals as standard equipment. The seal completely blocks the entry of foreign matter into the rolling surface and prevents loss of performance. In addition, rail covers* are also available for severe operating conditions. (Rail covers reduce the amount of foreign matter to 1/10 that of conventional linear guide for machine tools.)

The highly regarded NSK K1™ lubrication unit is also available to satisfy customer needs for long-term, maintenance-free operation.

* Rail covers are only available for the models of RA25 to 65.

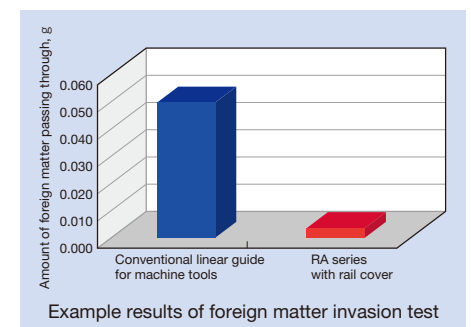

Low noise

A retaining piece is provided between rollers to prevent collision of rollers to minimize noise.

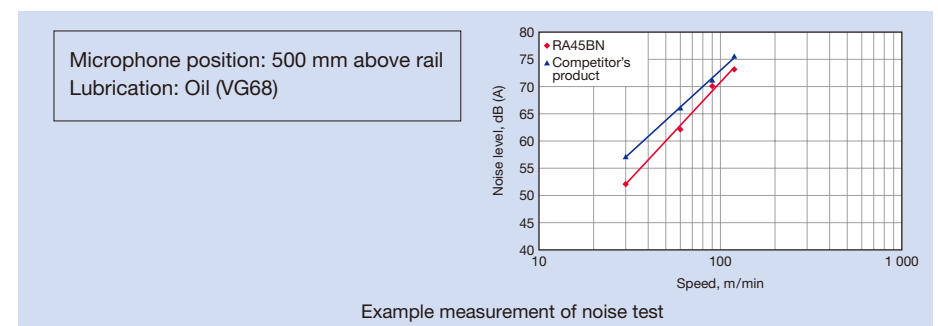

Specifications

1. Roller Slide Types and Shapes

- Two types of roller slides are available in this series: one with a mounting flange and a square type with tapped holes and no flange.
- A compact, low-profile square type is now available.
- On the mounting hole of the flange type, the tapped part is used to fix the roller slide from the top surface, and the minor diameter can be used as a bolt hole from the bottom. This provides mounting from both directions, top and bottom.
- Roller slide length can be specified by standard high load type or special long, super-high load type.

Fig. 1 Square type

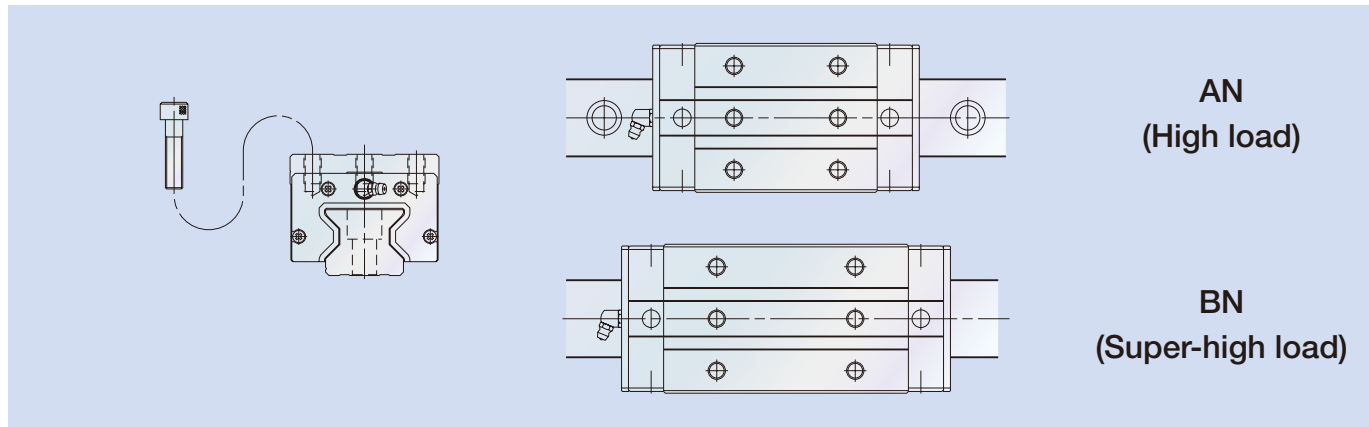

Fig. 2 Low-profile type

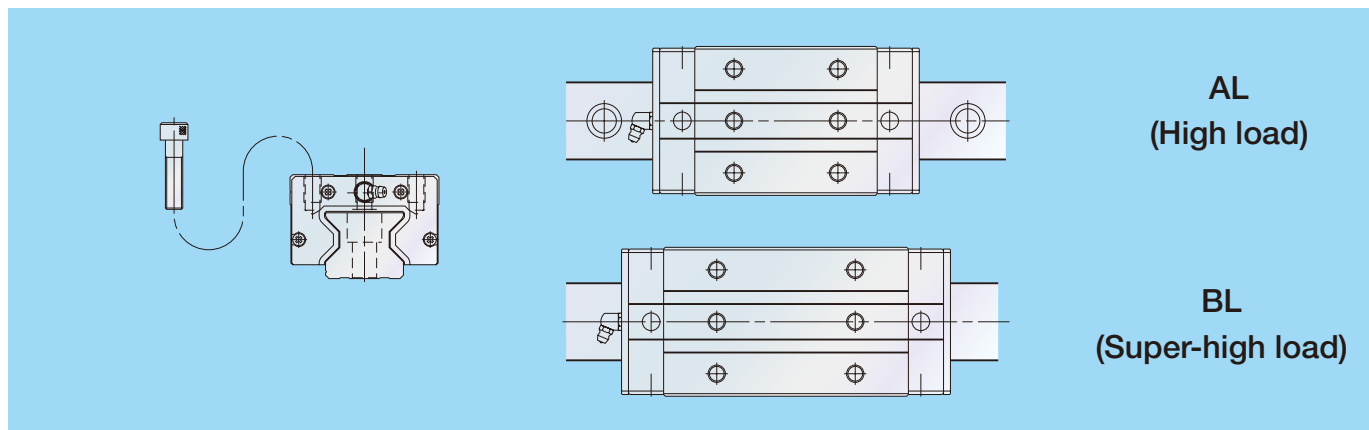
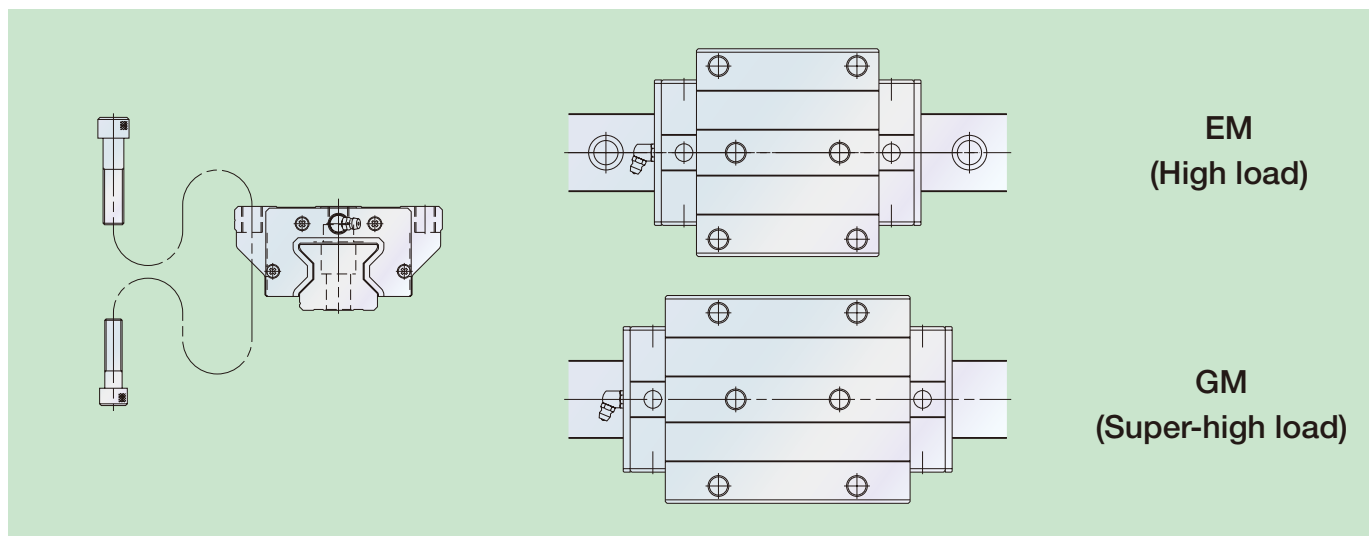

Fig. 3 Flange type



2. Accuracy

Four accuracy grades are available: ultra super precision P3, super precision P4, high precision P5, and precision P6.

Table 1 Accuracy standards

Unit: mm

Accuracy standards	Accuracy grades			
	Ultra super precision P3	Super precision P4	High precision P5	Precision P6
Mounting height: Dimensions in mounting height H	± 0.008	± 0.010	± 0.020	± 0.040
Mounting width: Dimensions in mounting width W_2 or W_3	± 0.010	± 0.015	± 0.025	± 0.050
Variation of mounting height dimension H	0.003	0.005	0.007	0.015
Variation of mounting width dimension W_2 or W_3^*	0.003	0.007	0.010	0.020
Running parallelism of face C against face A Running parallelism of face D against face B	Refer to Table 2			

* Difference in roller slides on the reference side roller guide.

Table 2 Running parallelism

Unit: μm

Rail length (mm)	Ultra super precision P3	Super precision P4	High precision P5	Precision P6
Over - 50 or less	2	2	2	4.5
50 - 80	2	2	3	5
80 - 125	2	2	3.5	5.5
125 - 200	2	2	4	6
200 - 250	2	2.5	5	7
250 - 315	2	2.5	5	8
315 - 400	2	3	6	9
400 - 500	2	3	6	10
500 - 630	2	3.5	7	12
630 - 800	2	4	8	14
800 - 1 000	2.5	4.5	9	16
1 000 - 1 250	3	5	10	17
1 250 - 1 600	4	6	11	19
1 600 - 2 000	4.5	7	13	21
2 000 - 2 500	5	8	15	22
2 500 - 3 000	6	9.5	17	25
3 150 - 3 500	9	16	23	30

Fig. 4 Specifications of accuracy

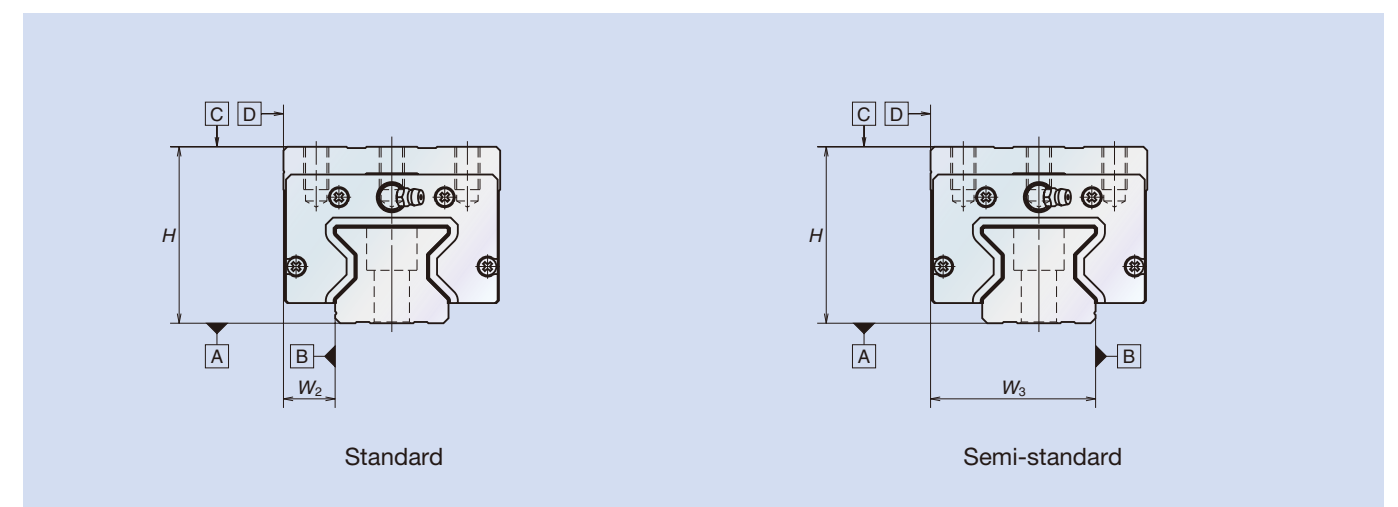

3. Preload and Rigidity

Preload is set for the RA series by slightly changing the size of the roller used. Applying preload enhances rigidity and minimizes elastic deformation. With the characteristics of the roller guide, there is minimal variation in rigidity according to amount of preload. Because the RA series offers stable, high rigidity, only medium preload type Z3 (preload: 10% of C, where C is the basic dynamic load rating) is set. Typical measurements for preload and rigidity are as follows.

Table 3 Preload Unit: N

Model No.	High load capacity type Medium preload (Z3)	Ultra High load capacity type Medium preload (Z3)
RA15	1 030	1 300
RA20	1 920	2 400
RA25	2 920	3 540
RA30	3 890	4 760
RA35	5 330	6 740
RA45	9 280	11 600
RA55	12 900	16 800
RA65	21 000	28 800

Fig. 5 Direction of load

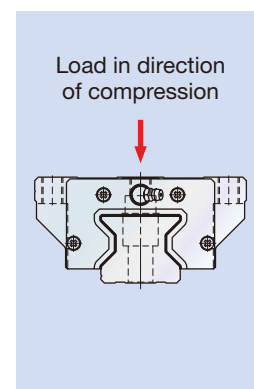
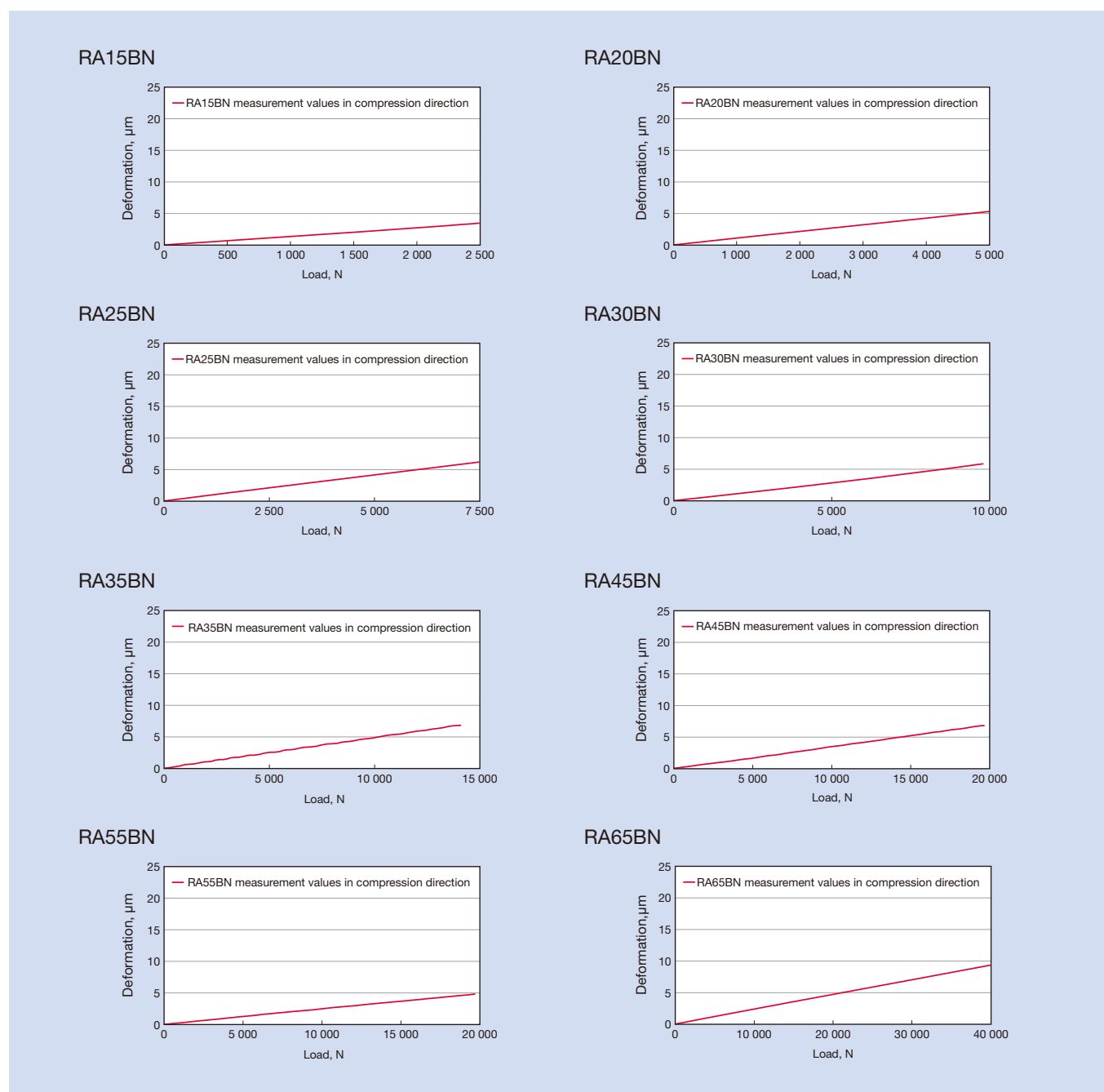

Fig. 6 Rigidity measurement data



4. Basic Load Rating and Rated Life

Basic dynamic load rating that expresses load capacity is established by ISO standards (ISO14728-1) for linear guides. With basic dynamic load rating, direction and size do not fluctuate so that rated fatigue life is 100 km. Load rating for NSK Linear Guides™ complies with ISO standards. With the RA series, dynamic load rating is the same in both the vertical and horizontal directions (4-way equal load specs.). Rated fatigue life L is calculated by the following formula when load F is applied to the roller slide in the horizontal or vertical direction only.

- This life formula is different from that for linear guides with ball rolling elements.
- f_w is load factor. Refer to the respective value from the following table 4 as a guideline according to potential vibration and the impact of the machine in which the linear guide is used, and select the load factor.

$$L = 100 \times \left(\frac{C}{f_w \cdot F} \right)^{\frac{10}{3}} \text{ (km)}$$

Table 4 Load factor f_w

Impact and/or vibration	Load factor
No impact and vibration from the outside	1.0 – 1.5
With impact and/or vibration from the outside	1.5 – 2.0
With heavy impact and/or vibration from the outside	2.0 – 3.0

Load applied to the linear guide (ball slide load) comes from various directions up/down and right/left directions and/or as moment load. Sometimes more than one type of load is applied simultaneously. Sometimes volume and direction of the load may change.

Varying load cannot be used as it is to calculate life of linear guide. Therefore, it is necessary to use a hypothetical load to ball slide with a constant volume, which would generate a value equivalent to an actual fatigue life. This is called “dynamic equivalent load.” For actual calculation, use the loads of Table 5.

Fig. 7 Direction of load

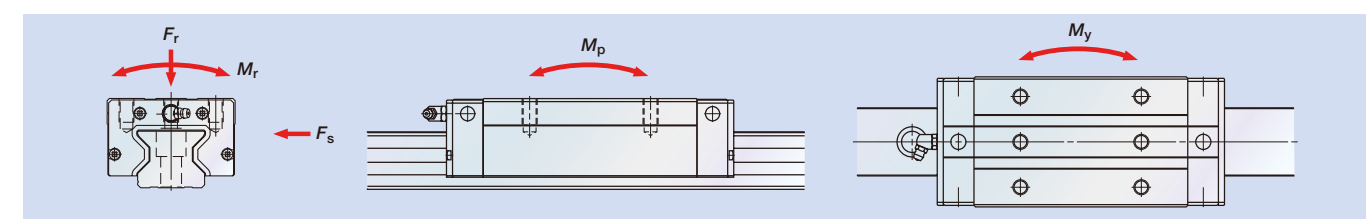

Table 5 Loads in the arrangement of linear guide

Pattern	Arrangement of linear guide	Loads necessary to calculate dynamic equivalent load					Dynamic equivalent load
		Up/down (vertical)	Right/left (lateral)	Rolling	Pitching	Yawing	
1		F_r	F_s	M_r	M_p	M_y	$F_e = F_r$ $F_{se} = F_s \tan \alpha$ $F_{re} = E_r M_r$ $F_{pe} = E_p M_p$ $F_{ye} = E_y M_y$
2		F_r	F_s	M_r			
3		F_r	F_s		M_p	M_y	
4		F_r	F_s				

Table 6 Dynamic equivalent coefficient

Model No.	Dynamic equivalent coefficient (1/m)		
	ϵ_r	ϵ_p	ϵ_y
RA15 High load type	105	95	95
RA15 Super-high load type	105	70	70
RA20 High load type	79	74	74
RA20 Super-high load type	79	55	55
RA25 High load type	71	64	64
RA25 Super-high load type	71	50	50
RA30 High load type	56	58	58
RA30 Super-high load type	56	44	44
RA35 High load type	46	53	53
RA35 Super-high load type	46	39	39
RA45 High load type	37	40	40
RA45 Super-high load type	37	30	30
RA55 High load type	33	34	34
RA55 Super-high load type	33	24	24
RA65 High load type	26	28	28
RA65 Super-high load type	26	19	19

Formula is determined by the relationship of loads in terms of volume. Full dynamic equivalent load can be easily obtained by using each coefficient.

After obtaining the dynamic equivalent of the necessary load directions from Table 6, use the formulas below to calculate full dynamic equivalent loads.

- When F_r is the largest load: $F_e = F_r + 0.5F_{se} + 0.5F_{re} + 0.5F_{pe} + 0.5F_{ye}$
- When F_{se} is the largest load: $F_e = 0.5F_r + F_{se} + 0.5F_{re} + 0.5F_{pe} + 0.5F_{ye}$
- When F_{re} is the largest load: $F_e = 0.5F_r + 0.5F_{se} + F_{re} + 0.5F_{pe} + 0.5F_{ye}$
- When F_{pe} is the largest load: $F_e = 0.5F_r + 0.5F_{se} + 0.5F_{re} + F_{pe} + 0.5F_{ye}$
- When F_{ye} is the largest load: $F_e = 0.5F_r + 0.5F_{se} + 0.5F_{re} + 0.5F_{pe} + F_{ye}$

For the values of each dynamic equivalent load in the formulas above, disregard load directions and take the absolute value.

5. Lubrication Specifications

With standard specifications, grease fittings are mounted on the side of the roller slide for the RA series, but can also be mounted on the side of the end cap with optional specifications. A lubrication hole can also be provided on the top of the end cap. Openings are not provided on the top or side with standard specifications in order to prevent dust. Contact NSK for more information.

Fig. 8 Lubrication hole positions

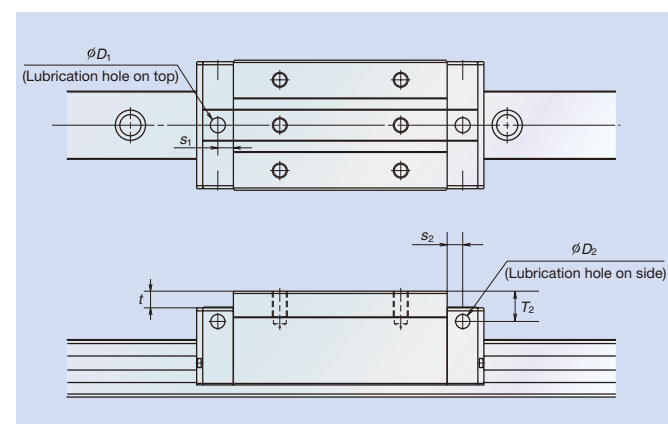

Table 7.1 Lubrication hole positions

Unit: mm

Model No.	Roller slide shape code	Grease nipple size	s_2	T_2	O ring	Spacer	D_1	s_1	t
RA15	AN, BN	$\phi 3$	4	7	P5	Need	8.2	4.4	4.2
RA20		$\phi 3$	4	4	P6	-	9.2	5.4	0.2
RA25		M6x0.75	6	10	P7	Need	10.2	6	4.5
RA30		M6x0.75	5	10	P7	Need	10.2	6	3.5
RA35		M6x0.75	5.5	15	P7	Need	10.2	7	7.4
RA45		Rc 1/8	7.2	20	P7	Need	10.2	7.2	10.4
RA55		Rc 1/8	7.2	21	P7	Need	10.2	7.2	10.4
RA65		Rc 1/8	7.2	19	P7	-	10.2	7.2	0.4

Table 7.2 Lubrication hole positions

Unit: mm

Model No.	Roller slide shape code	Grease nipple size	s_2	T_2	O ring	D_1	s_1	t
RA15	AL, BL, EM, GM	$\phi 3$	4	3	P5	8.2	4.4	0.2
RA20	EM, GM	$\phi 3$	4	4	P6	9.2	5.4	0.2
RA25	AL, BL, EM, GM	M6x0.75	6	6	P7	10.2	6	0.4
RA30		M6x0.75	5	7	P7	10.2	6	0.4
RA35		M6x0.75	5.5	8	P7	10.2	7	0.4
RA45		Rc 1/8	7.2	10	P7	10.2	7.2	0.4
RA55		Rc 1/8	7.2	11	P7	10.2	7.2	0.4
RA65	EM, GM	Rc 1/8	7.2	19	P7	10.2	7.2	0.4

6. Dust-proof

RA series is equipped with end, inner* and bottom seals to prevent foreign matter from entering the inside of the roller slide. Under normal applications, the RA series can be used without modification. For severe usage conditions, optional rail covers are available. Contact NSK for information on how to mount the cover. The linear guide can also be equipped with a lubrication unit (NSK K1™) that has already proven its effectiveness with other NSK Linear Guides™.

Table 8 Optional parts for dust-proofing

Name	Objective
NSK K1	Porous part containing oil enhances lubrication function.
Double seal	Sealing effect is enhanced by using pairs of side seals.
Protector	Removes large dust particles and protects side seals from hot and hard dust particles.
Rail cover**	Covers top of rail to prevent foreign matter from getting in the rail mounting holes.
Bolt hole cap	Prevents foreign matter such as cutting dust from collecting in the rail mounting holes.

* Inner seals for RA15 and RA20 are available as options. ** Rail cover is applicable to RA25 to 65.

Fig. 9 Rail cover



Fig. 10 View of the roller slide equipped with the dust proof parts

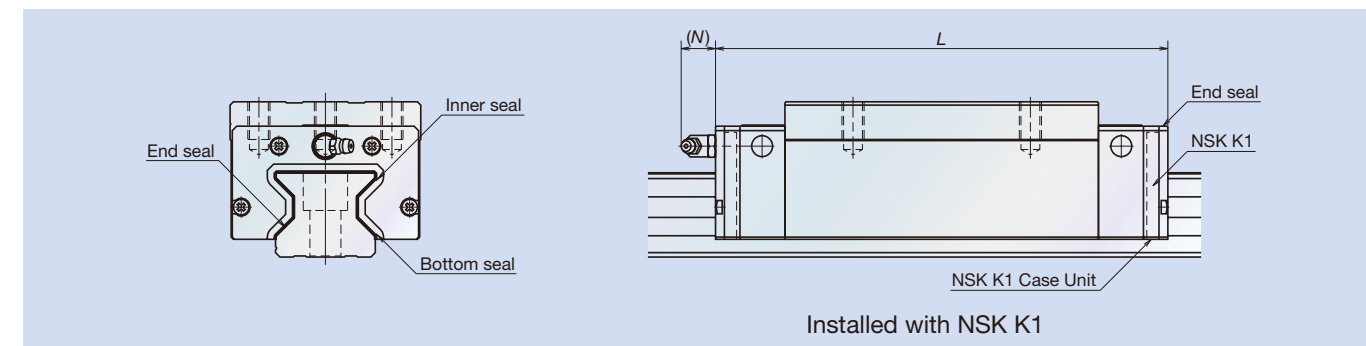
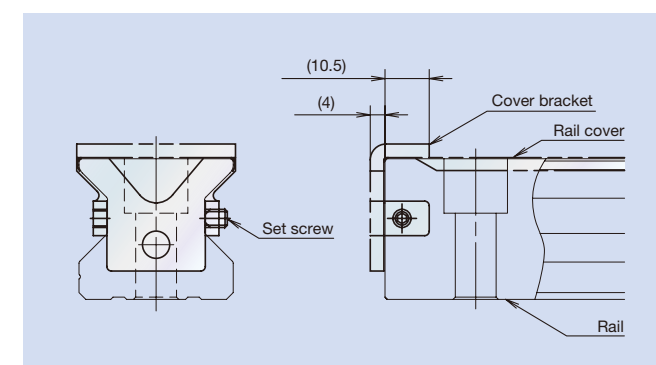

Table 9 Dimensions of roller slide assembly equipped with the optional parts

Model No.	Roller slide shape code	Roller slide length			
		Standard roller slide length	Roller slide length installed with NSK K1	Roller slide length installed with protector	Roller slide length installed with double seal
RA15	AN, AL, EM	70	79	75.4	76
	BN, BL, GM	85.4	94.4	90.8	91.4
RA20	AN, EM	86.5	95.5	93.1	92.5
	BN, GM	106.3	115.3	112.9	112.3
RA25	AN, AL, EM	97.5	107.5	104.1	103.9
	BN, BL, GM	115.5	125.5	122.1	121.9
RA30	AN, AL, EM	110.8	122.8	118	117.6
	BN, BL, GM	135.4	147.4	142.6	142.2
RA35	AN, AL, EM	123.8	136.8	131	130.6
	BN, BL, GM	152	165	159.2	158.8
RA45	AN, AL, EM	154	168	162.4	162
	BN, BL, GM	190	204	198.4	198
RA55	AN, AL, EM	184	198	192.4	192
	BN, BL, GM	234	248	242.4	242
RA65	AN, EM	228.4	243.4	239.4	238.4
	BN, GM	302.5	317.5	313.5	312.5

Above dimensions are for the assembly length of a roller slide equipped with one of the optional dust-proof parts on each end. Please consult with NSK for the dimensions when more than one kind of optional parts are used.

Fig. 11 End configuration of rail equipped with the rail cover



When the rail cover is used, use the cover bracket to secure the rail cover. Fig. 11 shows the dimensions for the cover bracket. The required room at the end of the rail is:

- Inside: 10 mm or less
- Outside: 4 mm or less

(Common to the models of RA25 to 65)

Please confirm the interference with your machine at the stroke end.

- Machine stroke
- Room for the end of the rail

Table 10 Height of rails equipped with rail cover

Model No.	Standard rail height H_1	Rail height installed with rail cover
RA25	24	24.25
RA30	28	28.25
RA35	31	31.25
RA45	38	38.3
RA55	43.5	43.8
RA65	55	55.3

The height of the rail with the rail cover is shown in Table 10.

7. Installation

(1) Mounting tolerance

Mounting tolerance results in harmful effects such as shortened operating life, deterioration in motion accuracy, and friction variation.

NSK particularly focuses on operating life, and sets an operating life value of more than 10 000 km calculated under the following conditions as mounting tolerance:

- The load per roller slide is 10% of basic dynamic load rating C.
- The rigidity of machine is infinite.

The tolerance in Fig. 12 is shown in the Table 11 as typical tolerance.

Fig. 12 Mounting tolerance

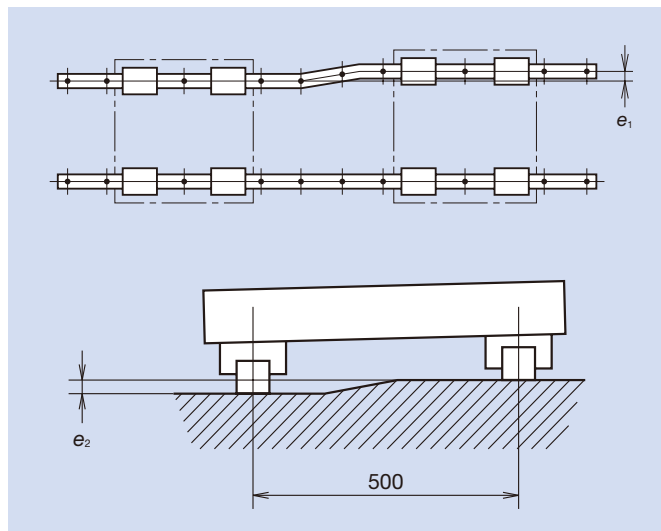

Table 11 Mounting tolerance of RA series Unit: μm

Model No.	Parallelism tolerance of two roller guides e_1	Height tolerance of two roller guides e_2
RA15	5	150 μm / 500 mm
RA20	7	
RA25	9	
RA30	11	
RA35	13	
RA45	17	
RA55	19	
RA65	30	

(2) Shoulder height and corner radius of mounting surface

When using the shoulders, which rise perpendicularly to the mounting surface, for accurate installation of a roller guide, refer to Fig. 13 and Table 12 for the dimensions.

Fig. 13 Datum face of roller guide and shoulder

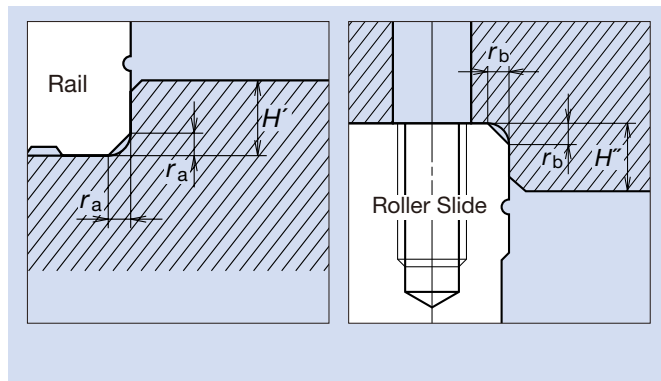

Table 12 Shoulder height and corner radius of attachment Unit: mm

Model No.	Shoulder Height		Chamfer (maximum)	
	H'	H''	r_a	r_b
RA15	3	4	0.5	0.5
RA20	4	5	0.5	0.5
RA25	4	5	0.5	1.0
RA30	5	6	1.0	1.0
RA35	5	6	1.0	1.0
RA45	6	8	1.5	1.0
RA55	7	10	1.5	1.5
RA65	11	11	1.5	1.5

8. Random matching type

Accuracy of the roller raceways and the mounting surfaces have been improved and we maintain stringent dimension controls on each component.

- Accuracy compatibility: Accuracy of precision class of P6 is assured even the rails and roller slides are randomly matched.
- Preload compatibility: Stringent dimension control assures proper preload for the specified rigidity.
- Rails and roller slides are selected and ordered in single unit quantities.
- Far greater accuracy of mounting dimensions
- Easy addition or replace of roller slides on a rail.

Fig. 14

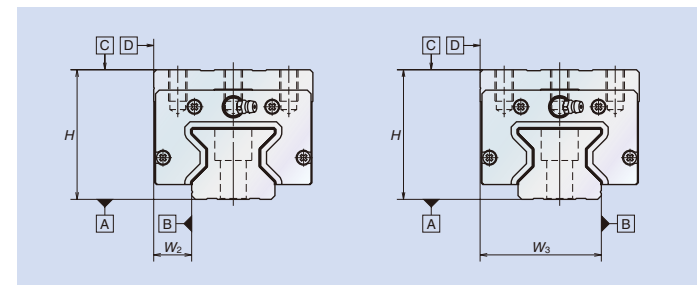

Table 13 Unit: mm

Accuracy standard	Precision P6
Assembly height: Dimension variation of H	± 0.020
Variation of dimension H (One rail)	0.015
Assembly width: Dimension variation of W_2 or W_3	± 0.025
Variation of dimension W_2 or W_3	0.020
Running parallelism standard	Refer to Precision P6 on the Table 2

Available models

Model No.: RA25, 30, 35, 45, 55, 65

Maximum rail length: 3 500 mm (3 000 mm Only, RA25)

Rail slide shape code: All shape code

(AN, BN, AL, BL, EM, GM)

Accuracy grade: P6 (Precision)

Preload: Z3 (Medium preload)

Surface treatment (optional): Fluoride low temperature chrome plating



Handling Precautions

- ① If oil lubrication is used, the oil may not pervade the rolling surface according to the roller slide mounting conditions such as upside down mounting and wall mounting. In these situations, consult with NSK.
- ② Operating temperature limits should normally be less than 80°C.
- ③ If using NSK K1™, service temperature should not exceed 50°C (or 80°C instantaneously). Make sure the unit does not come in contact with organic solvents with that can be used for degreasing. Do not place the unit in a location exposed to white kerosene or rust prevention oil containing white kerosene.
- ④ When transferring the roller slide onto the rail, or vice versa:
 - Do not remove an unnecessary roller slide from the rail as much as you can.
 - Use the provided provisional rail to prevent dents or scratches on the raceways caused by the roller slide that is jammed into the one from the other. It also prevents the rollers from dropping.
 - When transferring the roller slide onto the rail, or vice versa, butt the provisional rail up against the rail and slide it directly from one onto the other.
 - Use a clean provisional rail. Do not use the provisional rail that is contaminated with particles or uses different grease from that of the relevant roller slide.



Square type (tapped mounting holes)
RA-AN (High load type), RA-BN (Super-high load type)

Assembly

Example of specification number: **RA 35 1000 AN C 2 - ** P6 Z - II**

Series code: RA
Size No.: 35
Rail length (mm): 1000
Roller slide shape code: AN, BN
Material and surface treatment code, C: Special carbon steel (NSK standard)

Preload code 3: Z3 Medium preload
Z: Random matching with preload
Accuracy grade² (Without NSK K1): P3, P4, P5, P6
(With NSK K1): K3, K4, K5, K6
Design number: **
Number of roller slides per rail: 2
*II: two rails per axis
No code: single-rail

*1 Please note that the appropriate design number will be inserted into the reference number and the tag end code (-II) will be omitted.
*2 Only P6 and K6 grades are available for the random matching type.

Random matching rail

Example of specification number: **R1A 35 1000 LC N T** P6 Z**

RA Series random matching rail: R1A
Size No.: 35
Rail length (mm): 1000
Material and surface treatment code, C: Special carbon steel (NSK standard)

Preload code Z: Random matching with preload
Accuracy grade P6: Precision
Design number: T**
T: Domestic standard K: Domestic semi-standard B: International user standard
Butting specification: N: Non-butting specification L: Butting specification

Random matching roller slide

Example of specification number: **RAA 35 AN P6 Z**

RA Series random matching rail: RAA
Size No.: 35
Roller slide shape code: AN, BN
Accuracy grade P6: Precision
Z: Random matching with preload

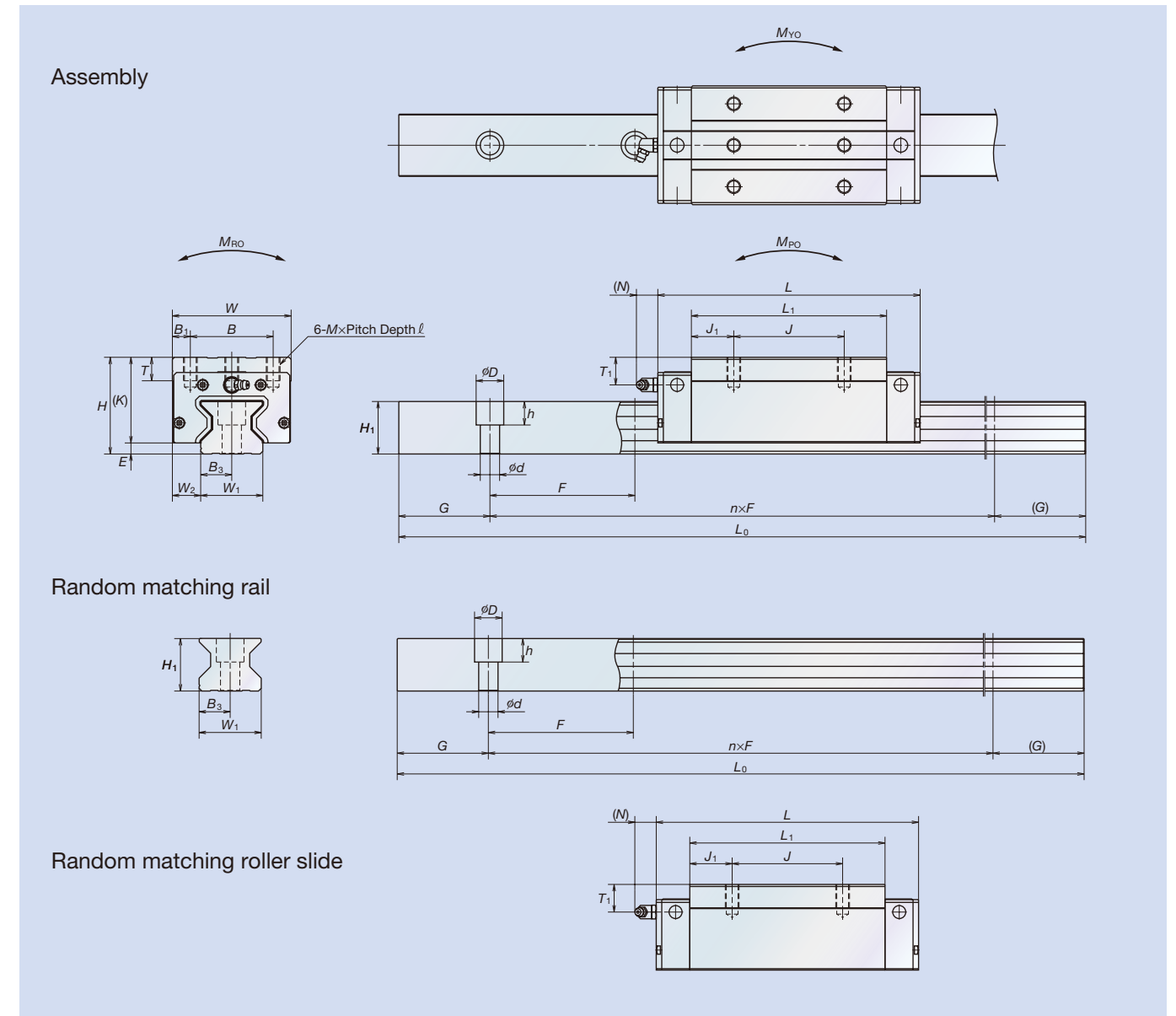

The basic load rating complies with ISO standards (ISO14728-1, ISO14728-2).
If the above basic dynamic load rating (100 km rating) is converted into 50 km rating, use the following formula:
 $C_{50\text{ km}} = 1.23 \times C_{100\text{ km}}$

Model No.	Assembly			Roller slide											Rail					Basic load rating					Weight					
	Height H	E	W ₂	Width W	Length L	Mounting hole			B ₁	L ₁	J ₁	K	T	Grease fitting			Rail width W ₁	Rail height H ₁	Bolt pitch F	Bolt hole d × D × h	B ₃	G (recommended)	Maximum length L _{0max}	Dynamic C (N)	Static C ₀ (N)	Static moment (N·m)			Roller slide (kg)	Rail (kg/m)
						B	J	M × Pitch × ℓ						Mounting hole	T ₁	N										M _{R0}	M _{P0}	M _{V0}		
RA15AN RA15BN	28	4	9.5	34	70 85.4	26	26	M4×0.7×6	4	44.8 60.2	9.4 17.1	24	8	φ3	8	3	15	16.3	60* (30)	4.5×7.5×5.3	7.5	20	2 000	10 300 13 000	27 500 37 000	260 350	210 375	210 375	0.21 0.30	1.6
RA20AN RA20BN	30	5	12	44	86.5 106.3	32	36 50	M5×0.8×6	6	57.5 77.3	10.75 13.65	25	12	φ3	4	3	20	20.8	60* (30)	6×9.5×8.5	10	20	3 000	19 200 24 000	52 500 70 000	665 890	505 900	505 900	0.38 0.50	2.6
RA25AN RA25BN	40	5	12.5	48	97.5 115.5	35	35 50	M6×1×9	6.5	65.5 83.5	15.25 16.75	35	12	M6×0.75	10	11	23	24	30	7×11×9	11.5	20	3 000	29 200 35 400	72 700 92 900	970 1 240	760 1 240	760 1 240	0.60 0.91	3.4
RA30AN RA30BN	45	6.5	16	60	110.8 135.4	40	40 60	M8×1.25×11	10	74 98.6	17 19.3	38.5	14	M6×0.75	10	11	28	28	40	9×14×12	14	20	3 500	38 900 47 600	93 500 121 000	1 670 2 170	1 140 1 950	1 140 1 950	1.0 1.3	4.9
RA35AN RA35BN	55	6.5	18	70	123.8 152	50	50 72	M8×1.25×12	10	83.2 111.4	16.6 19.7	48.5	15	M6×0.75	15	11	34	31	40	9×14×12	17	20	3 500	53 300 67 400	129 000 175 000	2 810 3 810	1 800 3 250	1 800 3 250	1.6 2.1	6.8
RA45AN RA45BN	70	8	20.5	86	154 190	60	60 80	M10×1.5×17	13	105.4 141.4	22.7 30.7	62	17	R _C 1/8	20	14	45	38	52.5	14×20×17	22.5	22.5	3 500	92 800 116 000	229 000 305 000	6 180 8 240	4 080 7 150	4 080 7 150	3.0 4.1	10.9
RA55AN RA55BN	80	9	23.5	100	184 234	75	75 95	M12×1.75×18	12.5	128 178	26.5 41.5	71	18	R _C 1/8	21	14	53	43.5	60	16×23×20	26.5	30	3 500	129 000 168 000	330 000 462 000	10 200 14 300	7 060 13 600	7 060 13 600	4.9 6.7	14.6
RA65AN RA65BN	90	13	31.5	126	228.4 302.5	76	70 120	M16×2×20	25	155.4 229.5	42.7 54.75	77	22	R _C 1/8	19	14	63	55	75	18×26×22	31.5	35	3 500	210 000 288 000	504 000 756 000	19 200 28 700	12 700 28 600	12 700 28 600	9.3 12.2	22.0

* Either 60 mm or 30 mm of bolt pitch F is applicable for RA15 and RA20.
60 mm bolt pitch will be provided if not specified.

● If the rail length exceeds the above limitation, you may be able to cope with the problem by rails for butting connections.
Contact NSK for more information.

Low profile type (tapped mounting holes)
RA-AL (High load type), RA-BL (Super-high load type)

Assembly

Example of specification number: **RA 35 1000 AL C 2 - ** P6 Z - II**

Series code: RA
Size No.: 35
Rail length (mm): 1000
Roller slide shape code: AL, BL
Material and surface treatment code, C: Special carbon steel (NSK standard)

Preload code 3: Z3 Medium preload
Z: Random matching with preload
Accuracy grade-2 (Without NSK K1): P3, P4, P5, P6 (With NSK K1): K3, K4, K5, K6

*II: two rails per axis
No code: single-rail

Design number: **
Number of roller slides per rail: 2

*1 Please note that the appropriate design number will be inserted into the reference number and the tag end code (-II) will be omitted.
*2 Only P6 and K6 grades are available for the random matching type.

Random matching rail

Example of specification number: **R1A 35 1000 LC N T** P6 Z**

RA Series random matching rail: R1A
Size No.: 35
Rail length (mm): 1000
Material and surface treatment code, C: Special carbon steel (NSK standard)

Preload code Z: Random matching with preload
Accuracy grade P6: Precision
Design number: T: Domestic standard, K: Domestic semi-standard, B: International user standard
Butting specification: N: Non-butting specification, L: Butting specification

Random matching roller slide

Example of specification number: **RAA 35 AL P6 Z**

RA Series random matching rail: RAA
Size No.: 35
Roller slide shape code: AL, BL
Z: Random matching with preload
Accuracy grade P6: Precision

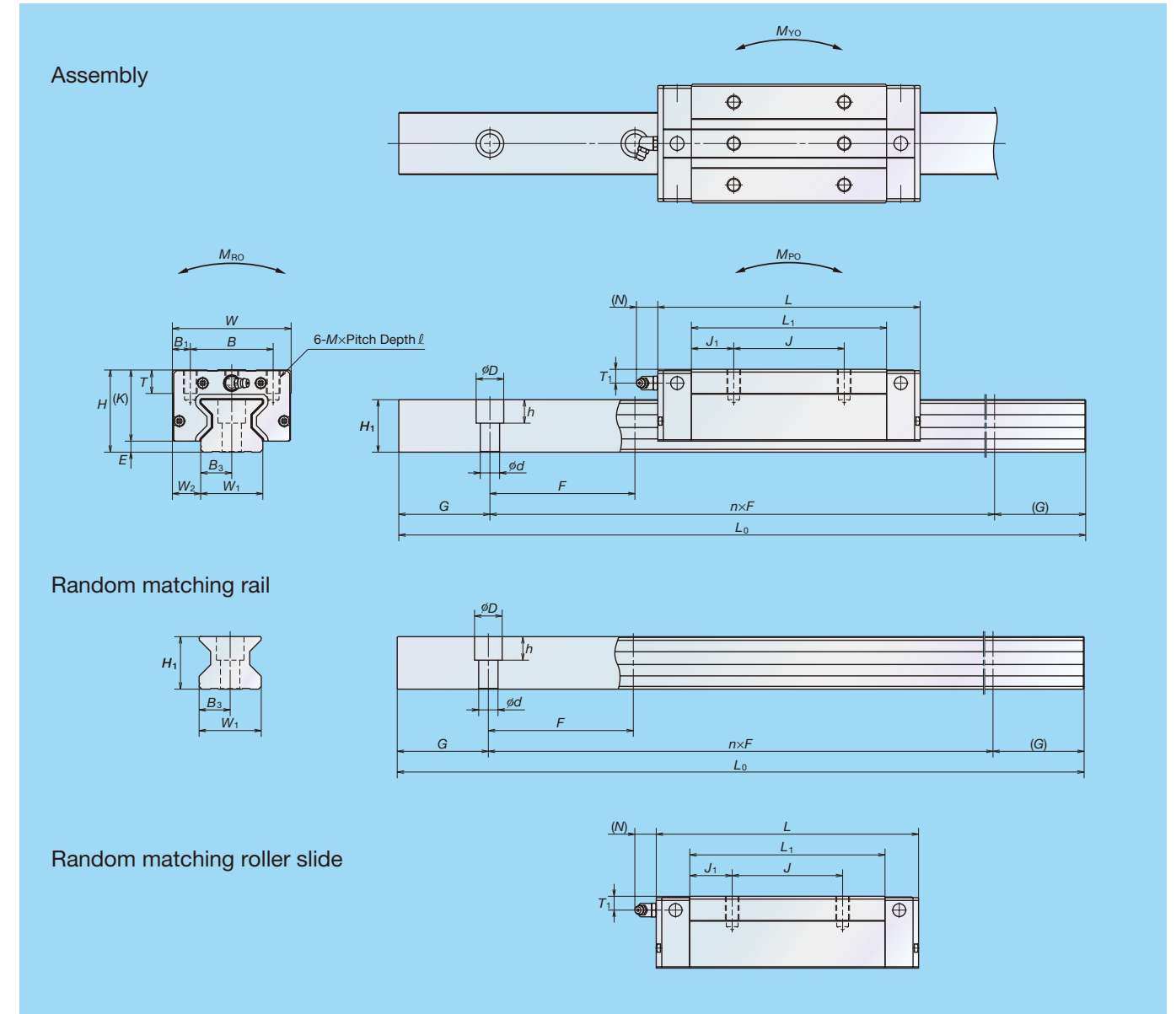

The basic load rating complies with ISO standards (ISO14728-1, ISO14728-2).
If the above basic dynamic load rating (100 km rating) is converted into 50 km rating, use the following formula:
 $C_{50\text{ km}} = 1.23 \times C_{100\text{ km}}$

Model No.	Assembly			Roller slide										Rail					Basic load rating					Weight						
	Height H	E	W ₂	Width W	Length L	Mounting hole			B ₁	L ₁	J ₁	K	T	Grease fitting			Rail width W ₁	Rail height H ₁	Bolt pitch F	Bolt hole d × D × h	B ₃	G (recommended)	Maximum length L _{0max}	Dynamic C (N)	Static C ₀ (N)	Static moment (N·m)			Roller slide (kg)	Rail (kg/m)
						B	J	M × Pitch × ℓ						Mounting hole	T ₁	N										M _{RO}	M _{PO}	M _{VO}		
RA15AL RA15BL	24	4	9.5	34	70 85.4	26	26	M4×0.7×5.5	4	44.8 60.2	9.4 17.1	20	8	φ3	4	3	15	16.3	60 * (30)	4.5×7.5×5.3	7.5	20	2 000	10 300 13 000	27 500 37 000	260 350	210 375	210 375	0.17 0.25	1.6
RA25AL RA25BL	36	5	12.5	48	97.5 115.5	35	35	M6×1×8	6.5	65.5 83.5	15.25 16.75	31	12	M6×0.75	6	11	23	24	30	7×11×9	11.5	20	3 000	29 200 35 400	72 700 92 900	970 1 240	760 1 240	760 1 240	0.45 0.80	3.4
RA30AL RA30BL	42	6.5	16	60	110.8 135.4	40	40	M8×1.25×11	10	74 98.6	17 19.3	35.5	14	M6×0.75	7	11	28	28	40	9×14×12	14	20	3 500	38 900 47 600	93 500 121 000	1 670 2 170	1 140 1 950	1 140 1 950	0.85 1.1	4.9
RA35AL RA35BL	48	6.5	18	70	123.8 152	50	50	M8×1.25×12	10	83.2 111.4	16.6 19.7	41.5	15	M6×0.75	8	11	34	31	40	9×14×12	17	20	3 500	53 300 67 400	129 000 175 000	2 810 3 810	1 800 3 250	1 800 3 250	1.2 1.7	6.8
RA45AL RA45BL	60	8	20.5	86	154 190	60	60	M10×1.5×16	13	105.4 141.4	22.7 30.7	52	17	R _C 1/8	10	14	45	38	52.5	14×20×17	22.5	22.5	3 500	92 800 116 000	229 000 305 000	6 180 8 240	4 080 7 150	4 080 7 150	2.5 3.4	10.9
RA55AL RA55BL	70	9	23.5	100	184 234	75	75	M12×1.75×18	12.5	128 178	26.5 41.5	61	18	R _C 1/8	11	14	53	43.5	60	16×23×20	26.5	30	3 500	129 000 168 000	330 000 462 000	10 200 14 300	7 060 13 600	7 060 13 600	4.1 5.7	14.6

* Either 60 mm or 30 mm of bolt pitch F is applicable for RA15 and RA20.
60 mm bolt pitch will be provided if not specified.

● If the rail length exceeds the above limitation, you may be able to cope with the problem by rails for butting connections.
Contact NSK for more information.

Flange type (for both tapped and bolt mounting holes)
RA-EM (High load type), RA-GM (Super-high load type)

Assembly

Example of specification number: **RA 35 1000 EM C 2 - ** P6 Z - II**

Series code: RA
Size No.: 35
Rail length (mm): 1000
Roller slide shape code: EM, GM
Material and surface treatment code: C: Special carbon steel (NSK standard)

Preload code 3: Z3 Medium preload
Z: Random matching with preload
Accuracy grade*2 (Without NSK K1): P3, P4, P5, P6 (With NSK K1): K3, K4, K5, K6
Design number: **
Number of roller slides per rail: 2
Tag end code: -II

*II: two rails per axis
No code: single-rail

*1 Please note that the appropriate design number will be inserted into the reference number and the tag end code (-II) will be omitted.
*2 Only P6 and K6 grades are available for the random matching type.

Random matching rail

Example of specification number: **R1A 35 1000 LC N T** P6 Z**

RA Series random matching rail: R1A
Size No.: 35
Rail length (mm): 1000
Material and surface treatment code: C: Special carbon steel (NSK standard)

Preload code Z: Random matching with preload
Accuracy grade P6: Precision
Design number: T: Domestic standard, K: Domestic semi-standard, B: International user standard
Butting specification: N: Non-butting specification, L: Butting specification

Random matching roller slide

Example of specification number: **RAA 35 EM P6 Z**

RA Series random matching rail: RAA
Size No.: 35
Roller slide shape code: EM, GM
Preload code Z: Random matching with preload
Accuracy grade P6: Precision

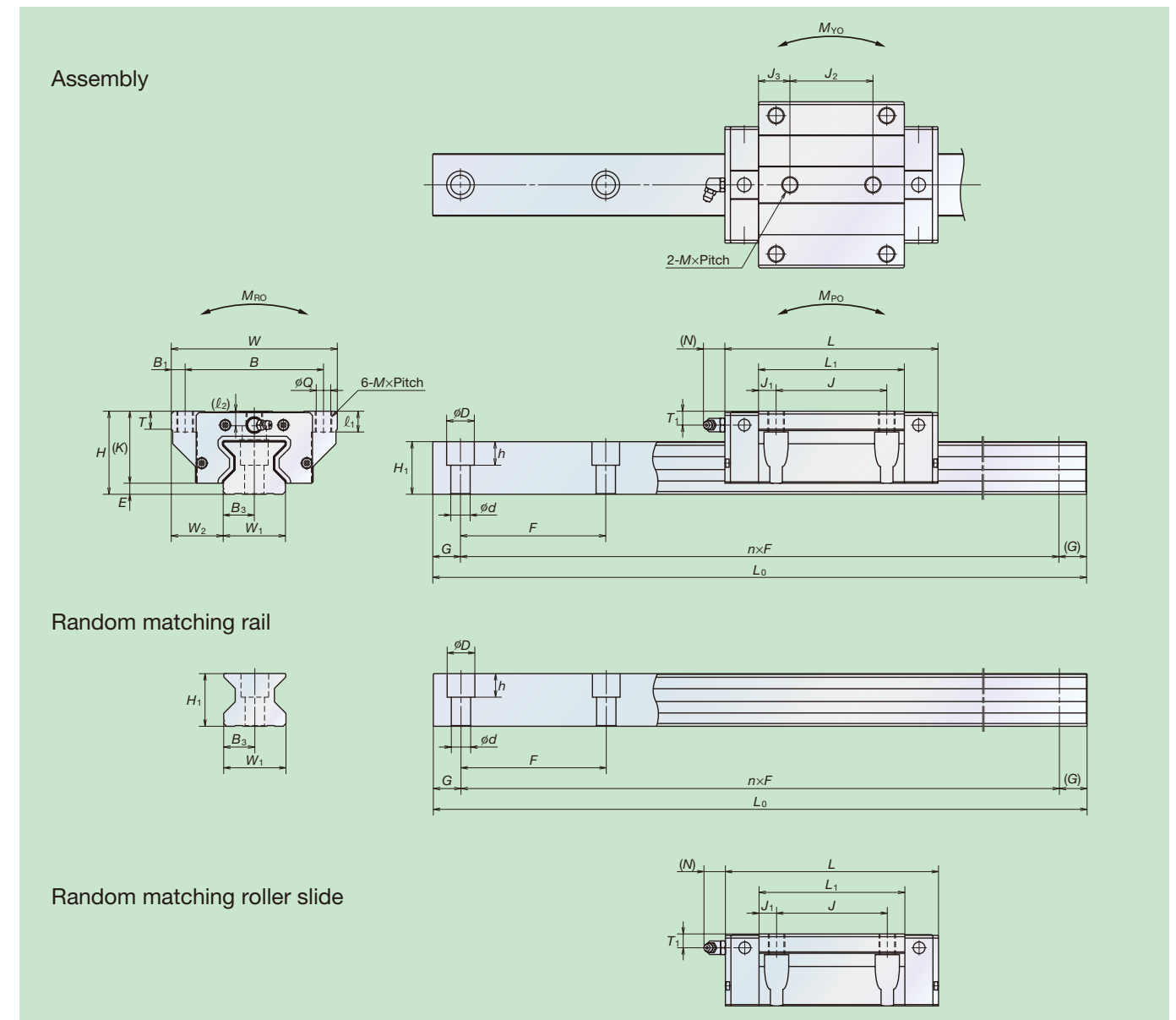

The basic load rating complies with ISO standards (ISO14728-1, ISO14728-2).
If the above basic dynamic load rating (100 km rating) is converted into 50 km rating, use the following formula:
 $C_{50 km} = 1.23 \times C_{100 km}$

Model No.	Assembly			Roller slide													Rail					Basic load rating					Weight							
	Height H	E	W ₂	Width W	Length L	Mounting hole						B ₁	L ₁	J ₁	J ₃	K	T	Grease fitting			Rail width W ₁	Rail height H ₁	Bolt pitch F	Bolt hole d×D×h	B ₃	G (recommended)	Maximum length L _{0max}	Dynamic C (N)	Static C ₀ (N)	Static moment (N·m)			Roller slide (kg)	Rail (kg/m)
						M×Pitch	l ₁ (l ₂)	Q×l ₁ (l ₂)	Q ₁	T ₁	N							M _{R0}	M _{P0}	M _{Y0}														
RA15EM RA15GM	24	4	16	47	70 85.4	38	30	26	M5×0.8×8.5 (6.5)	4.4×8.5 (6.5)	4.5	44.8 60.2	7.4 15.1	9.4 17.1	20	8	φ3	4	3	15	16.3	60* (30)	4.5×7.5×5.3	7.5	20	2 000	10 300 13 000	27 500 37 000	260 350	210 375	210 375	0.21 0.28	1.6	
RA20EM RA20GM	30	5	21.5	63	86.5 106.3	53	40	35	M6×1×9.5 (8)	5.3×9.5 (8)	5	57.5 77.3	8.75 18.65	11.25 21.15	25	10	φ3	4	3	20	20.8	60* (30)	6×9.5×8.5	10	20	3 000	19 200 24 000	52 500 70 000	665 890	505 900	505 900	0.45 0.65	2.6	
RA25EM RA25GM	36	5	23.5	70	97.5 115.5	57	45	40	M8×1.25×10 (11)	6.8×10 (11)	6.5	65.5 83.5	10.25 19.25	12.75 21.75	31	11	M6×0.75	6	11	23	24	30	7×11×9	11.5	20	3 000	29 200 35 400	72 700 92 900	970 1 240	760 1 240	760 1 240	0.80 1.1	3.4	
RA30EM RA30GM	42	6.5	31	90	110.8 135.4	72	52	44	M10×1.5×12 (12.5)	8.6×12 (12.5)	9	74 98.6	11 23.3	15 27.3	35.5	11	M6×0.75	7	11	28	28	40	9×14×12	14	20	3 500	38 900 47 600	93 500 121 000	1 670 2 170	1 140 1 950	1 140 1 950	1.3 1.7	4.9	
RA35EM RA35GM	48	6.5	33	100	123.8 152	82	62	52	M10×1.5×13 (7)	8.6×13 (7)	9	83.2 111.4	10.6 24.7	15.6 29.7	41.5	12	M6×0.75	8	11	34	31	40	9×14×12	17	20	3 500	53 300 67 400	129 000 175 000	2 810 3 810	1 800 3 250	1 800 3 250	1.7 2.3	6.8	
RA45EM RA45GM	60	8	37.5	120	154 190	100	80	60	M12×1.75×15 (10.5)	10.5×15 (10.5)	10	105.4 141.4	12.7 30.7	22.7 40.7	52	13	R _C 1/8	10	14	45	38	52.5	14×20×17	22.5	22.5	3 500	92 800 116 000	229 000 305 000	6 180 8 240	4 080 7 150	4 080 7 150	3.2 4.3	10.9	
RA55EM RA55GM	70	9	43.5	140	184 234	116	95	70	M14×2×18 (13)	12.5×18 (13)	12	128 178	16.5 41.5	29 54	61	15	R _C 1/8	11	14	53	43.5	60	16×23×20	26.5	30	3 500	129 000 168 000	330 000 462 000	10 200 14 300	7 060 13 600	7 060 13 600	5.4 7.5	14.6	
RA65EM RA65GM	90	13	53.5	170	228.4 302.5	142	110	82	M16×2×24 (18.5)	14.6×24 (18.5)	14	155.4 229.5	22.7 59.75	36.7 73.75	77	22	R _C 1/8	19	14	63	55	75	18×26×22	31.5	35	3 500	210 000 288 000	504 000 756 000	19 200 28 700	12 700 28 600	12 700 28 600	12.2 16.5	22.0	

* Either 60 mm or 30 mm of bolt pitch F is applicable for RA15 and RA20. 60 mm bolt pitch will be provided if not specified.

● If the rail length exceeds the above limitation, you may be able to cope with the problem by rails for butting connections. Contact NSK for more information.

Worldwide Sales Offices

NSK LTD.-HEADQUARTERS, TOKYO, JAPAN INDUSTRIAL MACHINERY BEARINGS DIVISION-HEADQUARTERS AFTERMARKET BUSINESS DIVISION-HEADQUARTERS AUTOMOTIVE BUSINESS DIVISION-HEADQUARTERS PRECISION MACHINERY & PARTS DIVISION-HEADQUARTERS	www.nsk.com tel: 03-3779-7227 tel: 03-3779-8893 tel: 03-3779-7189 tel: 03-3779-7163	PT. NSK INDONESIA Jakarta	www.id.nsk.com tel: 021-252-3458	Netherlands: NSK EUROPEAN DISTRIBUTION CENTRE B.V. Tilburg	tel: 013-4647647
Africa South Africa: NSK SOUTH AFRICA (PTY) LTD. Johannesburg	tel: 011-458-3600	Korea: NSK KOREA CO., LTD. Seoul Changwon Plant	www.kr.nsk.com tel: 02-3287-0300 tel: 055-287-6001	Poland: NSK EUROPE LTD. WARSAW LIAISON OFFICE Warsaw	tel: 022-645-1525
Asia and Oceania Australia: NSK AUSTRALIA PTY. LTD. Melbourne	www.au.nsk.com tel: 03-9764-8302	Malaysia: NSK BEARINGS (MALAYSIA) SDN BHD Shah Alam NSK MICRO PRECISION (M) SDN. BHD. Malaysia Plant	www.my.nsk.com tel: 03-7803-8859 www.my.nsk.com tel: 03-8961-3960	NSK BEARINGS POLSKA S.A. Kielce Plant	tel: 041-366-5001
China: NSK HONG KONG LTD. Hong Kong Shenzhen	tel: 2739-9933 tel: 0755-25904886	New Zealand: NSK NEW ZEALAND LTD. Auckland	www.nsk-rhp.co.nz tel: 09-276-4992	NSK EUROPEAN TECHNOLOGY CENTER, POLAND OFFICE Kielce	tel: 041-366-5812
KUNSHAN NSK CO., LTD. Kunshan Plant	tel: 0512-5771-5654	Philippines: NSK REPRESENTATIVE OFFICE Manila	tel: 02-893-9543	NSK STEERING SYSTEMS EUROPE (POLSKA) SP.ZO.O. Walbrzych	tel: 074-664-4101
CHANGSHU NSK NEEDLE BEARING CO., LTD. Jiangsu Plant	tel: 0512-5230-1111	Singapore: NSK INTERNATIONAL (SINGAPORE) PTE LTD. Singapore	tel: 6496-8000	NSK NEEDLE BEARING POLAND SP.ZO.O. Kielce	tel: 041-345-2469
NSK STEERING SYSTEMS DONGGUAN CO., LTD. Dongguan Plant	tel: 0769-2262-0960	Singapore (PRIVATE) LTD. www.nsk-singapore.com.sg Singapore	tel: 6496-8000	Spain: NSK SPAIN S.A. Barcelona	tel: 093-433-5775
ZHANGJIAGANG NSK PRECISION MACHINERY CO., LTD. Zhangjiagang Plant	tel: 0512-5867-6496	Taiwan: TAIWAN NSK PRECISION CO., LTD. Taipei	tel: 02-2509-3305	Turkey: NSK RULMANLARI ORTA DOGU TIC. LTD. STI. Istanbul	tel: 0216-355-0399
SUZHOU NSK BEARINGS CO., LTD. Suzhou Plant	tel: 0512-6665-5666	TAIWAN NSK TECHNOLOGY CO., LTD. Taipei	tel: 02-2509-3305	United Kingdom: NSK BEARINGS EUROPE LTD. Peterlee Plant	tel: 0191-586-6111
NSK CHINA TECHNOLOGY CENTER Jiangsu	tel: 0512-5771-5654	Thailand: NSK BEARINGS (THAILAND) CO., LTD. Bangkok	tel: 02641-2150	NSK EUROPEAN TECHNOLOGY CENTRE Newark	tel: 01636-605-123
NSK (SHANGHAI) TRADING CO., LTD. Shanghai	tel: 021-6235-0198	NSK BEARINGS MANUFACTURING (THAILAND) CO., LTD. Chonburi	tel: 038-454-010	NSK UK Ltd. Newark	tel: 01636-605-123
NSK REPRESENTATIVE OFFICES Beijing	www.nsk.com.cn tel: 010-6590-8161	NSK ASIA PACIFIC TECHNOLOGY CENTER (THAILAND) CO., LTD. Chonburi	tel: 038-454-631	NSK PRECISION UK LTD. Newark	tel: 01636-605-123
Guangzhou	tel: 020-3786-4833	Vietnam: NSK VIETNAM CO., LTD. Hanoi	tel: 04-3955-0159	NSK STEERING SYSTEMS EUROPE LTD. Maidenhead	tel: 01628-509-800
Chengdu	tel: 028-8661-4200	Ho Chi Minh City	tel: 08-3822-7907	North and South America NSK AMERICAS, INC. (AMERICAN HEADQUARTERS) Ann Arbor	tel: 734-913-7500
NSK (CHINA) INVESTMENT CO., LTD. Shanghai	tel: 021-6235-0198	NSK REPRESENTATIVE OFFICE Ho Chi Minh City	tel: 08-3822-7907	Argentina: NSK ARGENTINA SRL Buenos Aires	tel: 11-4704-5100
NSK CHINA SALES CO., LTD. Shanghai	tel: 021-6235-0198	Europe NSK EUROPE LTD. (EUROPEAN HEADQUARTERS) Maidenhead	www.eu.nsk.com tel: 01628-509-800	Brazil: NSK BRASIL LTDA. Sao Paulo	www.br.nsk.com tel: 011-3269-4786
NSK WARNER (SHANGHAI) CO., LTD. Plant	tel: 021-3365-5757	France: NSK FRANCE S.A.S Paris	tel: 01-30-57-39-39	Canada: NSK CANADA INC. Toronto	www.ca.nsk.com tel: 905-890-0740
AKS PRECISION BALL (HANGZHOU) CO., LTD. Plant	tel: 0571-2280-1288	Germany: NSK DEUTSCHLAND GMBH Düsseldorf	tel: 02102-4810	Mexico: NSK RODAMIENTOS MEXICANA, S.A. DE C.V. Mexico City	www.mx.nsk.com tel: 55-5390-4312
India: RANE NSK STEERING SYSTEMS LTD. Chennai	tel: 044-274-66002	NSK PRECISION EUROPE GMBH Düsseldorf	tel: 02102-4810	United States of America: NSK CORPORATION Ann Arbor	www.us.nsk.com tel: 734-913-7500
NSK INDIA SALES CO. PVT. LTD. Chennai	tel: 044-2433-1161	NEUWEG FERTIGUNG GMBH Munderkingen Plant	tel: 07393-540	NSK AMERICAN TECHNOLOGY CENTER Ann Arbor	tel: 734-913-7500
Gurgaon	tel: 0124-4104-530	Italy: NSK ITALIA S.P.A. Milano	tel: 0299-5191	NSK PRECISION AMERICA, INC. Franklin	www.npa.nsk.com tel: 317-738-5000
Kolkata	tel: 033-4001-2062	INDUSTRIA CUSCINETTI S.P.A. Torino Plant	tel: 011-982-4811	NSK STEERING SYSTEMS AMERICA, INC. Bennington	www.nssa.nsk.com tel: 802-442-5448
Mumbai	tel: 022-2838-7787			NSK LATIN AMERICA, INC. Miami	www.la.nsk.com tel: 305-477-0605
NSK-ABC BEARINGS LTD. Chennai	tel: 044-2714-3000				
Indonesia: PT. NSK BEARINGS MANUFACTURING INDONESIA Jakarta Plant	tel: 021-898-0155				

NSK Ltd. has a basic policy not to export any products or technology designated as controlled items by export-related laws. When exporting the products in this brochure, the laws of the exporting country must be observed. Specifications are subject to change without notice and without any obligation on the part of the manufacturer. Every care has been taken to ensure the accuracy of the data contained in this brochure, but no liability can be accepted for any loss or damage suffered through errors or omissions. We will gratefully acknowledge any additions or corrections.

For more information about NSK products, please contact: _____

