

User manual

magnetic absolute
positioning drive with **CANopen** interface

AG03

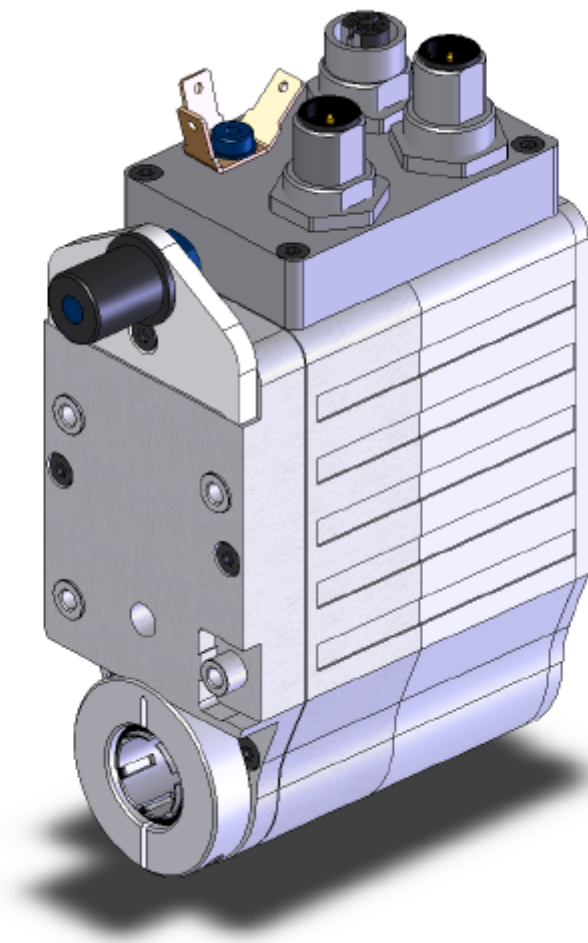



1	GENERAL REMARKS.....	5
1.1	SYMBOLS AND THEIR MEANING	5
1.2	DOCUMENTATION	5
2	FUNCTIONAL DESCRIPTION	6
2.1	SYSTEM STATUS WORD.....	6
2.2	OPERATING MODES	7
2.2.1	<i>Positioning mode</i>	7
2.2.1.1	Loop positioning	8
2.2.1.2	Inching operation	9
2.2.2	<i>Velocity mode</i>	10
2.3	TORQUE DEACTIVATION	11
2.4	RESTORE FACTORY SETTINGS VIA DIP SWITCHES	12
2.5	ENABLE INPUT	12
2.6	DRIVE BEHAVIOR IN CASE OF POWER FAILURE	12
3	CALIBRATION.....	13
4	EXTERNAL GEAR UNIT	13
5	WARNINGS / FAULTS	13
5.1	WARNINGS.....	14
5.2	FAULTS.....	14
5.2.1	<i>Error codes</i>	14
6	PARAMETER DESCRIPTION.....	15
7	COMMUNICATION VIA CAN BUS	18
7.1	GENERAL REMARKS.....	18
7.1.1	<i>Interface</i>	18
7.2	CANOPEN PROTOCOL	18
7.2.1	<i>Telegram setup</i>	18
7.2.2	<i>Network management (NMT)</i>	19
7.2.2.1	State Diagramm.....	20
7.2.2.2	NMT Status 'INITIALISATION'	20
7.2.2.3	NMT Status 'PRE-OPERATIONAL'	20
7.2.2.4	NMT Status 'OPERATIONAL'	20
7.2.2.5	NMT Status 'STOPPED'	20
7.2.2.6	Switching between communication states.....	21
7.2.3	<i>SYNC object</i>	21
7.2.4	<i>Process Data Objects (PDOs)</i>	21
7.2.5	<i>Transmit PDOs</i>	22
7.2.5.1	1 st Transmit PDO (TPDO1).....	22
7.2.5.2	3 rd Transmit PDO (TPDO3)	22
7.2.5.3	4 th Transmit PDO (TPDO4)	22
7.2.5.4	Transfer types of the Transmit PDOs	23
7.2.6	<i>Receive PDOs</i>	23
7.2.6.1	1 st Receive PDO (RPDO1)	23
7.2.6.2	3 rd Receive PDO (RPDO3)	24
7.2.6.3	4 th Receive PDO (RPDO4)	24
7.2.6.4	Transfer types of the Receive PDOs.....	25
7.2.7	<i>Service Data Objects (SDOs)</i>	25
7.2.7.1	Error code	26
7.2.8	<i>Example: Parameterization</i>	26
7.2.8.1	Example: Read parameter.....	27
7.2.8.2	Example: Write parameter	27
7.2.9	<i>Emergency Object (EMCY)</i>	28
7.2.9.1	Error Code	28



7.2.10	Heartbeat protocol	30
7.2.11	Node Guarding.....	30
7.3	STATE MACHINE.....	31
7.4	STATUS WORD	33
7.5	CONTROL WORD.....	35
7.6	FLOWCHART OF THE PROFILE POSITION MODE (POSITIONING MODE)	37
7.7	FLOWCHART OF THE PROFILE VELOCITY MODE OPERATION MODE (VELOCITY MODE)	38
7.8	EXAMPLES	39
7.8.1	Example of the Profile Position Mode (positioning mode).....	39
7.8.2	Example of the Profile Velocity Mode (velocity mode)	39
7.9	OVERVIEW OF CANOPEN IDENTIFIERS.....	40
7.10	SETTING THE CAN BAUD RATE.....	40
7.11	EDS FILE	40
7.12	DIRECTORY OF OBJECTS.....	40
7.12.1	Overview of objects	41
7.12.2	Description of objects	42
7.12.2.1	1000 _h : Device Type	43
7.12.2.2	1001 _h : Error Register.....	43
7.12.2.3	1002 _h : Manufacturer Status Register	44
7.12.2.4	1003 _h : Pre-defined Error Field.....	44
7.12.2.5	1005 _h : COB-ID Sync Message	45
7.12.2.6	1008 _h : Manufacturer Device Name	45
7.12.2.7	100A _h : Manufacturer Software Version	46
7.12.2.8	100C _h : Guard Time.....	46
7.12.2.9	100D _h : Life Time Factor.....	46
7.12.2.10	1011 _h : Restore Default Parameters	47
7.12.2.11	1014 _h : COB-ID Emergency Message	48
7.12.2.12	1017 _h : Producer Heartbeat Time	48
7.12.2.13	1018 _h : Identity Objekt.....	49
7.12.2.14	1200 _h : Server SDO Parameter.....	50
7.12.2.15	1400 _h : 1 st Receive PDO Parameter.....	51
7.12.2.16	1401 _h : 2 nd Receive PDO Parameter	52
7.12.2.17	1402 _h : 3 rd Receive PDO Parameter.....	53
7.12.2.18	1403 _h : 4 th Receive PDO Parameter.....	54
7.12.2.19	1600 _h : 1 st Receive PDO Mapping Parameter	56
7.12.2.20	1601 _h : 2 nd Receive PDO Mapping Parameter	56
7.12.2.21	1602 _h : 3 rd Receive PDO Mapping Parameter.....	57
7.12.2.22	1603 _h : 4 th Receive PDO Mapping Parameter.....	58
7.12.2.23	1800 _h : 1 st Transmit PDO Parameter.....	59
7.12.2.24	1801 _h : 2 nd Transmit PDO Parameter	61
7.12.2.25	1802 _h : 3 rd Transmit PDO Parameter.....	62
7.12.2.26	1803 _h : 4 th Transmit PDO Parameter.....	63
7.12.2.27	1A00 _h : 1 st Transmit PDO Mapping Parameter	65
7.12.2.28	1A01 _h : 2 nd Transmit PDO Mapping Parameter.....	66
7.12.2.29	1A02 _h : 3 rd Transmit PDO Mapping Parameter	66
7.12.2.30	1A03 _h : 4 th Transmit PDO Mapping Parameter	67
7.12.2.31	2100 _h : CAN baud rate	68
7.12.2.32	2101 _h : Node-ID.....	68
7.12.2.33	2102 _h : Gear reduction	69
7.12.2.34	2410 _h : Motor Parameter Set	69
7.12.2.35	2412 _h : Spindle Pitch.....	71
7.12.2.36	2413 _h : Pos Type.....	71
7.12.2.37	2415 _h : Delta Jog.....	71
7.12.2.38	2416 _h : Stop Mode Inching Mode 2.....	72
7.12.2.39	2417 _h : Inpos Mode	72
7.12.2.40	2418 _h : Loop Length	72
7.12.2.41	2420 _h : Generic Status Register.....	72
7.12.2.42	2421 _h : Torque Deactivation.....	73
7.12.2.43	2422 _h : Torque Deactivation State	73
7.12.2.44	2500 _h : Production Date	73



7.12.2.45	6040 _h : Control word.....	74
7.12.2.46	6041 _h : Status word	74
7.12.2.47	6060 _h : Modes of Operation	74
7.12.2.48	6064 _h : Position Actual Value	75
7.12.2.49	6067 _h : Position Window	75
7.12.2.50	606C _h : Velocity Actual Value	75
7.12.2.51	607A _h : Target Position	76
7.12.2.52	607C _h : Calibration Value	76
7.12.2.53	607D _h : Software Position Limit.....	76
7.12.2.54	607E _h : Polarity.....	77
7.12.2.55	6091 _h : Gear Ratio.....	77
7.12.2.56	60FF _h : Target Velocity.....	78
7.13	SETTING THE NODE ADDRESS OF THE AG03	78
7.14	DIAGNOSIS LEDs	79
7.15	CAN BUS TERMINATION	79

1 General remarks

This user manual is valid with firmware version 2.08 or higher!

1.1 Symbols and their meaning



This symbol precedes passages in the text that should be read with particular care to ensure flawless use of the AG03.



This symbol precedes passages in the text that contain additional important information.

1.2 Documentation

This user manual is valid for the AG03 absolute positioning drive and is intended to provide you with the necessary information on programming and activation of the AG03 positioning drive.



Please refer to the User Information for information on mechanical mounting, electrical connection, general safety instructions, correct usage as well as commissioning of the positioning drive.

2 Functional description

This chapter describes the operating cycles, functions and states required for the operation of the positioning drive.

Communication via CANopen is taken as the basis for the information presented in this chapter.

2.1 System status word

The system status word of the AG03 consists of 2 bytes and reflects the state of the AG03. The system status word can be read via Object 1002_h (Manufacturer Status Register).

High- Byte							Low- Byte								
Bit – number															
15	14	13	12	11	10	9	8	7	6	5	4	3	2	1	0
0	0	1	0	1	0	0	1	0	1	0	0	1	0	0	0
2				9				4				8			

Fig. 1: System status word format

Example (grey background):

binary: P 0010 1001 0100 1000

hex: P 2 9 4 8

The table below informs about the meaning of the individual bits of the status word:

Bit	State	Description
Bit 0	'0'	no meaning
Bit 1	'0'	no meaning
Bit 2	'0'	no meaning
Bit 3	'1'	Positioning mode: In position Actual position is within the positioning window of the programmed target value.
	'0'	Actual position is beyond the positioning window of the programmed target value.
	'1'	Velocity mode: In position Actual velocity is within the specified tolerance window of the target speed
	'0'	Actual speed is outside the specified tolerance window.
Bit 4	'1'	Drive travels: Drive travels
	'0'	Drive stands still (velocity < 2 rev./min)
Bit 5	'1'	Positioning mode: upper limit: Actual position is above the higher programmed limit of limits 1+2. Travelling is possible only in negative direction in inching operation.
	'0'	Actual position is below the programmed limit.
	'0'	Velocity mode: no meaning
Bit 6	'1'	Positioning mode: lower limit: Actual position is below the lower programmed limit of limits 1+2. Travelling is possible only in positive direction in inching operation.
	'0'	Actual position is above the programmed limit.
	'0'	Velocity mode: no meaning

Bit	State	Description
Bit 7	'1'	Driver state: Motor is enabled
	'0'	Motor in control
Bit 8	'1'	Fault: The AG03 has switched to fault. The cause of the fault must be cleared and acknowledged via 'CW.7=1' command. For the fault cause see chapter 5.2
	'0'	No fault present
Bit 9	'1'	Positioning mode: loop travel: If travel direction unequal start direction (with loop travel)
	'0'	If travel direction equal start direction
	'0'	Velocity mode: no meaning
Bit 10	'1'	Status of the enable input Enable input deactivated Gear travel is disabled!
	'0'	Enable input activated
Bit 11	'1'	Ready-to-travel: Not ready-to-travel
	'0'	Ready-to-travel: <ul style="list-style-type: none"> • AG03 not in fault state • No active positioning • Enable input activated • actual position within limits (only positioning mode)
Bit 12	'1'	Battery voltage: Battery voltage too low for absolute encoder. Have the battery replaced at SIKO's within half a year after notice of error bit!
	'0'	Battery voltage OK.
Bit 13	'1'	Motor current: Motor current beyond permissible range. If this state lasts for more than 4 sec., the AG03 switches to fault.
	'0'	Motor current within permissible range.
Bit 14	'1'	Positioning mode: status Positioning active in positioning mode.
	'0'	Positioning inactive.
	'0'	Velocity mode: no meaning
Bit 15	'1'	Lag error: Lag error ⇒ AG03 cannot reach the preset speed due to too high load. This state should be avoided! Remedy: reduce programmed speed!
	'0'	No lag error ⇒ actual speed corresponds with required speed.

Table 1: System status word

2.2 Operating modes

The following operating modes are available: positioning mode and velocity mode.
In the positioning mode there is the additional option of travelling with inching operation.

2.2.1 Positioning mode

Parameter no 20 'Operating mode' is programmed to positioning mode (see chapter 6: Parameter description)

In the positioning mode, positioning to the target value is effected by means of a ramp function (see fig. 2), which is calculated on the basis of the actual position as well as the programmed controller parameters P (proportional factor), I (integral factor), D (differential factor), acceleration and speed (see chapter 6: Parameter description).

After activation of the travel order (see *chapter 7.5.3 Flowchart: Positioning mode*) the AG03 accelerates with the pre-programmed acceleration to the specified speed. The measure of deceleration to reach the target value is also defined by the parameter 'a-pos'.

If the actual position is within the programmed window (see *chapter 6: parameter no. 10*), this will be signalled in the system status word (bit 3). The drive's behaviour upon reaching the pre-programmed window can be defined (see *chapter 6: parameter no. 26*).

Changing controller parameters during a positioning process does not influence the current positioning operation.

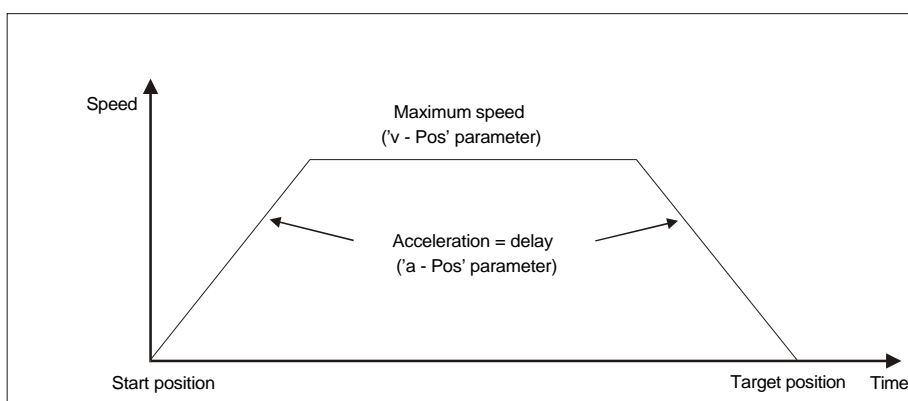

Fig. 2: Ramp travel in positioning mode (direct)

Travel orders can only be started if the following conditions have been met:

- the AG03 must not be switched to fault (*system status word bit 8 = '0'*)
- actual position is within the programmed limiting values. (*system status word bits 5 + 6 = '0'*)
- no active travel job present (*system status word bit 14 = 0*)
- Enable input activated (*system status word bit 10 = '0'*)

ZSW.15 = '1' is signalled when these conditions have been met.

2.2.1.1 Loop positioning

If the AG03 is operated on a spindle or an additional drive, the spindle or external drive play can be compensated by means of loop positioning.

In this case, travelling to the target value is always from the same direction.

This travel direction can be defined via the parameter no. 19 'Pos- Art' (see *chapter 6: Parameter description*).

Example:

Assumption: The direction of travelling for reaching any target position is positive (see *chapter 6: Parameter no. 19 'Pos Art' = loop*)

- Case 1 \Rightarrow new position is greater than actual position:

Direct travel to target position.

- Case 2 \Rightarrow new position is smaller than actual position:

The AG03 travels beyond the target position by the loop length (parameter no. 27) (bit 9 in the system status word signals travel direction unequal start direction); afterwards, travelling to the target value is in positive direction.

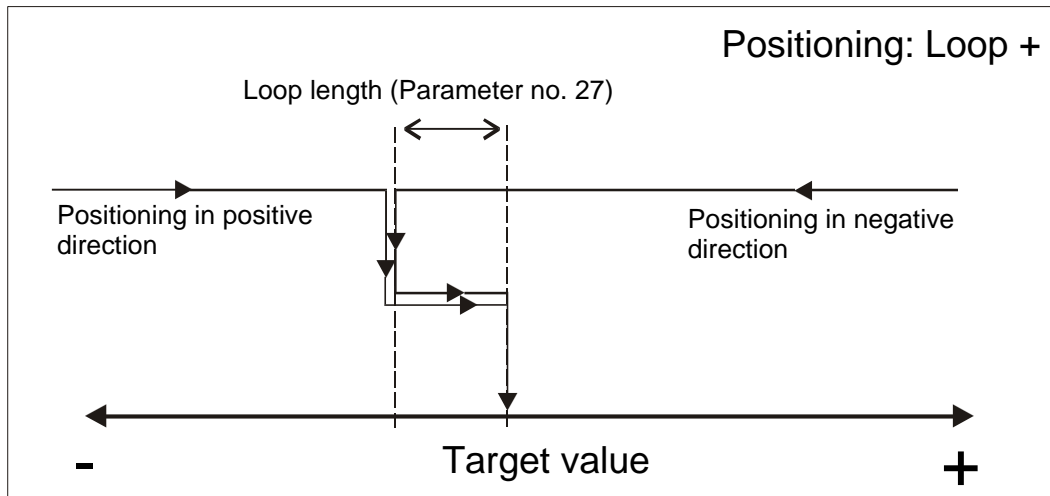

Fig. 3: Loop+ positioning

2.2.1.2 Inching operation

Inching operation is enabled in the 'Positioning mode' only. Acceleration and speed in the inching operation can be programmed via parameter no. 8 'a- Inch' and parameter no. 9 'v- Inch'.



There is no compensation for spindle play (loop positioning) in this travel type!

There are three options for travelling with inching operation:

- **Inching operation 1**

Inching operation 1 is started via CW.13 = '1' in the control word.

The drive travels once from the current position by the position 'Delta Inch'.

The travel direction is positive or negative depending on the arithmetical sign (*parameter no. 17 'Delta- Inch'*).

- Parameter 'Delta Inch' < 0: negative travel direction
- Parameter 'Delta Inch' > 0: positive travel direction

If the parameter no. 13 'Spindle pitch' is programmed to zero, then there is an incremental travelling way. If the 'spindle pitch' is unequal zero, then the information of the 'Delta Inch' parameter refers to the travel distance in 1/100 mm.

Reaching the target position will be signalled in the system status word (bit 3).

- **Inching operation 2**

Inching operation is started via CW.14 = '1' (positive travel direction) or CW.15 = '1' (negative travel direction), respectively.

The drive moves at the pre-programmed speed as long as this bit = '1'.

- **Touch button operation**

By opening the two Phillips screws on the front plate the touch buttons can be accessed.

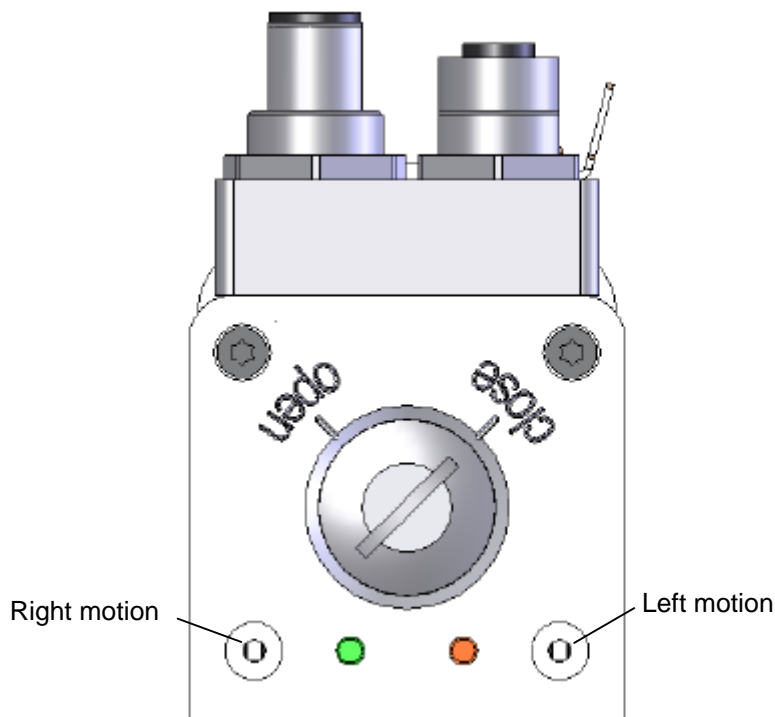

Touch button operation is unavailable for NMT states “OPERATIONAL” and “STOPPED”.

The following conditions must be met for enabling the start of inching operations 1 and 2 or touch button operation via standard protocol:

- The AG03 must not be switched to fault (*system status word bit 8 = '0'*)
- No active travel job present (*system status word bit 14 = '0'*)
- Enable input activated (*system status word bit 10 = '0'*)



If the actual position is outside the programmed limiting values or a limit switch is active, then travelling from this position to the respective direction is possible by means of inching operations 1 or 2 or touch button operation!

2.2.2 Velocity mode

Parameter no 20 'operating mode' is programmed to velocity mode (*see chapter 6: Parameter description*).

In the velocity mode, the AG03 accelerates to the target velocity after release of the setpoint value (*see chapter 7.5.6 flowchart: velocity mode*) and maintains this velocity until the setpoint value is disabled or a new target velocity specified.

The speed is adjusted immediately to the new value when the rotational target speed is changed.

The arithmetical sign of the target value determines the travel direction in the velocity mode (*see chapter 6: Parameter description*).

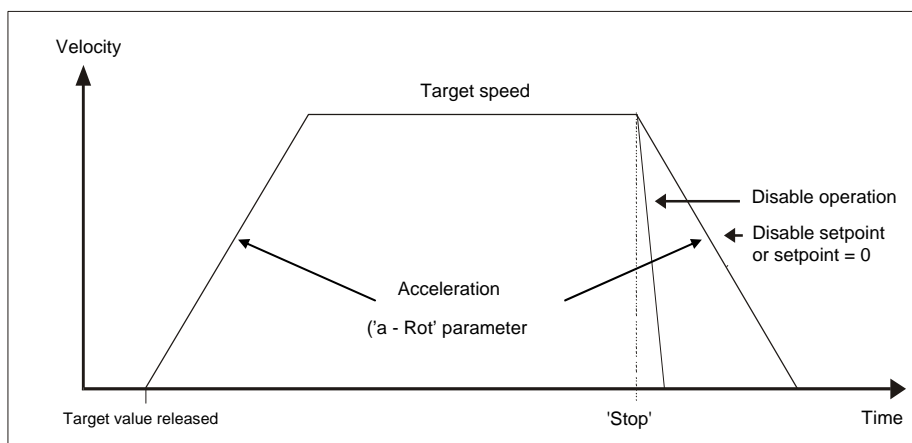

Fig. 5: Ramp velocity mode

The following conditions must be met for enabling start of velocity mode via the 'M' command of the standard protocol:

- The AG03 must not be switched to fault (*system status word bit 8 = '0'*)
- no active travel job present (*system status word bit 14 = '0'*)
- Enable input activated (*system status word bit 10 = '0'*)

If these conditions are met, this will be signalled in the system status word by bit 11 = '0'.



Limits 1 + 2 are deactivated in this operational mode!

2.3 Torque deactivation

A deactivation threshold is defined via the torque deactivation parameter (*see chapter 6: Parameter description P Parameter No. 29*). Percent values are entered. Torque deactivation is disabled with a parameter value of 125%.

The drive will decelerate with maximum delay when the deactivation threshold is exceeded. Drive control will be maintained.



Active torque deactivation causes no error!

Active deactivation is signaled in Object 2422_h (Torque Deactivation State) Bit 0 = '1'. This bit will be automatically reset when the current travel order is resumed. Alternately, the status of torque deactivation is mapped in Object 2420_h (Generic State Register).



This function is only available in the positioning mode!

2.4 Restore factory settings via DIP switches

Procedure for restoring factory settings via the 10-pin DIP switch:

1. Switch off supply voltage.
2. Set DIP switches 1 – 8 depending on the parameters to be reset:

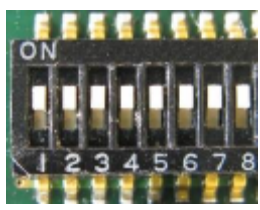
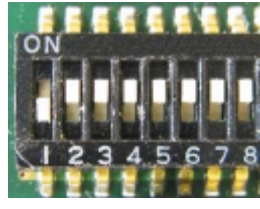
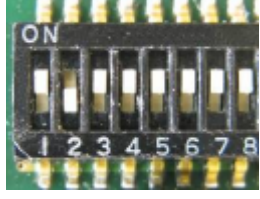
Reset all parameters (see chapter 6: <i>Parameter description</i>) to factory settings	
Reset only standard parameters (see chapter 6: <i>Parameter description</i>) to factory settings	
Reset only controller parameters (see chapter 6: <i>Parameter description</i>) to factory settings	

3. Turn on supply voltage. AG03 acknowledges with alternating blinking of the status LED and the bus LED.
4. Switch off supply voltage.
5. Set the original bus address via DIP switches 1 - 7.
6. DIP switch number 8 must be set to the OFF position.
7. After next switching on of supply voltage, the previously selected parameters will have been reset to the factory settings.

2.5 Enable input

The drive can only be started with enable input activated (i.e., high level is applied to the enable input). Removing enable results in immediate activating of the final stage. The motor is no longer able to generate torque.



If the drive moving when enable is removed, then the drive will run out non-braked!

2.6 Drive behavior in case of power failure



**Power failure results in immediate loss torque.
If the drive is moving at the time of power failure, then the drive will run out non-braked!**

3 Calibration

Since the measuring system is an absolute system, calibration is necessary only once at start-up. During calibration, the position value of the AG03 is set to the programmed calibration value (see chapter 6: Parameter description \mathcal{P} parameter no. 14).

The measuring system is calibrated via Object 1011_h (Restore Default Parameters).



Calibration is only possible when no travel job is active!

4 External gear unit

If an external gear unit is used, a factor can be programmed via the parameter no. 11 'ü - Numerator' (numerator) and parameter no. 12 'ü - Denominator' (denominator), in order to include the gear ratio in position sensing (see also chapter 2.2.1.1).

Example (see fig. 7):

The AG03 is operated on a gear with transfer reduction of 5:1. For this purpose, the parameters 'ü-Numerator' and 'ü-Denominator' must be programmed as follows:

- Parameter 'ü - Numerator' : 5
- Parameter 'ü - Denominator' : 1

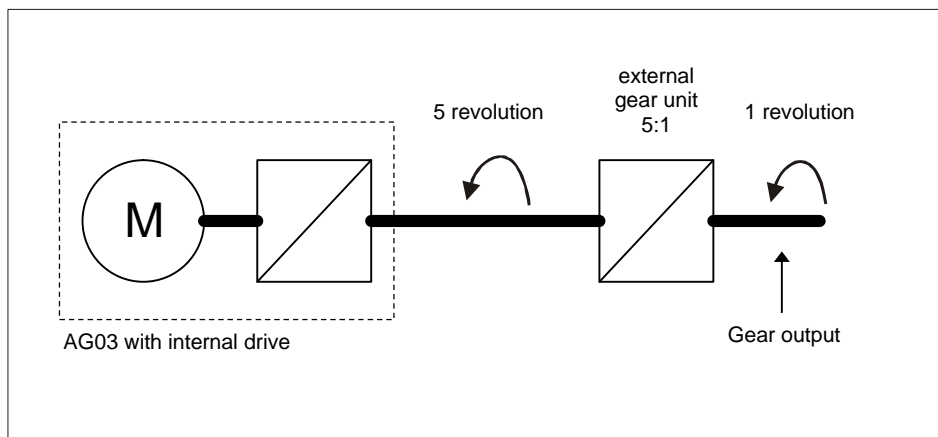

Fig. 7: External gear unit

Input of an odd gear reduction value is possible according to the following example:

Transfer reduction = 3.78

- Parameter 'ü - Numerator' : 378
- Parameter 'ü - Denominator' : 100

5 Warnings / Faults

The AG03 distinguishes between warnings and faults:



5.1 Warnings

Warnings do not influence the operation of the positioning drive. Warnings disappear after removing their causes.

Possible warnings:

- Battery voltage for absolute encoder is below limit \Rightarrow exchange battery within the next 6 months (see chapter 2.1: system status word **P** bit 12).
- Motor current beyond the permissible range (see chapter 2.1: System status word **P** bit 13) \Rightarrow if this condition lasts longer than 4 seconds, the AG03 will switch to fault.
- Lag error present (see chapter 2.1: System status word \Rightarrow bit 15) \Rightarrow AG03 cannot reach programmed speed because load is too high.

5.2 Faults

Faults induce an immediate stop of the positioning drive. The status-LED signalizes the fault status (see User information). Based on the blink code, the cause of the fault can be tracked down (see tab. 2: Error codes). Furthermore, a pending error can be detected via the status word (see CAN-Bus chapter 7.4: Status word).

The error messages are entered in the error buffer in the order of their detection. The last 10 fault messages are displayed when the fault buffer is full.

The cause of an error can be tracked down with the help of the error codes (see table 2: Error codes). The error buffer is stored in the EEPROM and can be deleted via Object "Pre-defined Error Field" (see CAN-Bus chapter 7.12.2 Object 1003_n).

5.2.1 Error codes

The following table lists possible error causes:

Value error buffer	Blink code green Status-LED	Error description
A	blinking 1 time	supply voltage too low Error condition: Supply voltage < 18V + motor current > 200mA
B	blinking 2 times	blocked drive shaft Error condition: Revolutions per minute < rpm + contouring error
C	blinking 3 times	motor current too high Error condition: Motor current > 2,4A more than 4s
D	blinking 4 times	output stage temperature too high Error condition: Output stage temperature > 90°C
E	blinking 5 times	reserved
F	blinking 6 times	internal error
G	blinking 7 times	intermediate circuit voltage too high Error condition: Intermediate circuit voltage > 35V
H	blinking 8 times	CAN-BUS error CAN-node switched to "ERROR PASSIVE" status during running positioning
I	blinking 9 times	CAN-BUS error CAN-node switched to "BUS OFF" status.

Table 2: Error codes

6 Parameter description

This chapter describes the parameters of the AG03.

All parameters are stored in the **non-volatile** EEPROM, except for parameter 24 (target value).

* Controller parameters

** Standard parameters

Nr.	Name	Selection / value	Default	Description
1	Controller parameter P *	1 – 500	100	P gain of controller: valid for all operating modes (positioning mode, velocity mode, inching operation) <i>CAN-Bus chapter 7.12.2: object 2410_h P sub-index 01_h</i>
2	Controller parameter I *	0 – 500	5	I gain of controller: valid for all operating modes (positioning mode, velocity mode, inching operation) <i>CAN-Bus chapter 7.12.2: object 2410_h P sub-index 02_h</i>
3	Controller parameter D *	0 – 500	0	D gain of controller: valid for all operating modes (positioning mode, velocity mode, inching operation) <i>CAN-Bus chapter 7.12.2: object 2410_h P sub-index 03_h</i>
4	a – Pos *	1 – 100	50	Acceleration in positioning mode: values in % (100% ⇒ 4rev/sec./sec.) <i>CAN-Bus chapter 7.12.2: object 2410_h P sub-index 04_h</i>
5	v – Pos *	1 – 100 1 – 200	30	Maximum speed in positioning mode: values in revolutions/min gear ratio 48:1 ⇒ max. 100 rev/min gear ratio 24:1 ⇒ max. 200 rev/min <i>CAN-Bus chapter 7.12.2: object 2410_h P sub-index 05_h</i>
6	a - Rot *	1 – 100	50	Acceleration in velocity mode: values in % (100% ⇒ 4 rev /sec./sec.) <i>CAN-Bus chapter 7.12.2: object 2410_h P sub-index 06_h</i>
7				reserviert
8	a - Inch *	1 – 100	50	Acceleration in inching operation 1 /2: values in % (100% ⇒ 4 rev /sec./sec.) <i>CAN-Bus chapter 7.12.2: object 2410_h P sub-index 08_h</i>
9	v - Inch *	1 – 100 1 – 200	30	Maximum speed in inching operation 1 /2: values in revolutions/min gear ratio 48:1 ⇒ max. 100 rev/min gear ratio 24:1 ⇒ max. 200 rev/min <i>CAN-Bus chapter 7.12.2: object 2410_h P sub-index 09_h</i>
10	Pos- Window **	0 - 1000	10	Positioning mode: positioning window If the actual position of the AG03 is within the programmed target value ± this window, this is signalled by setting bit 3 in the system status word of the AG03 (see chapter 2.1) Spindle pitch = 0: Information refers to increments Spindle pitch + 0: Information refers to travelling distance in 1/100 mm Velocity mode: Velocity window If the actual velocity is within the target velocity ± this window, this is signalled by setting bit 3 in the system status word of the AG03 (see chapter 2.1). <i>CAN-Bus chapter 7.12.2: object 6067_h</i>
11	ü – Numerator**	1 – 10000	1	Numerator gear ratio: a gear ratio can be programmed here when a gear unit is used (see chapter 4: external gear unit). <i>CAN-Bus chapter 7.12.2: object 6091_h P sub-index 01_h</i>

Nr.	Name	Selection / value	Default	Description
12	ü – Denominator **	1 – 10000	1	Denominator gear ratio: a gear ratio can be programmed here when a gear unit is used (see chapter 4: external gear unit). <i>CAN-Bus chapter 7.12.2: object 2410_h P sub-index 02_h</i>
13	Spindle pitch **	0 – 1000	0	Spindle pitch: Spindle pitch = 0: Position value is output in increments (1,600 increments per revolution of the driving shaft of the AG03). Spindle pitch parameter + 0: (when operating the AG03 on a spindle) Position value is no longer output as increments, but as travelling distance in 1/100 mm. Target position is entered now as 1/100 mm, too. Spindle pitch value in 1/100mm. e.g. spindle with a pitch of 2mm ⇒ spindle pitch parameter = 200. <i>CAN-Bus chapter 7.12.2: object 2412_h</i>
14	Calibration value **	-999999 to 999999	0	Calibration value: Writing a value in this parameter results in the take-over of this value as the absolute position for the AG03. Caution! Value must be within the range of the preprogrammed limiting values. <i>CAN-Bus chapter 7.12.2: object 607C_h</i>
15	Litmit 1 **	-9999999 to 9999999	1000000	Positioning mode: Litmit 1 Spindle pitch = 0: Information refers to increments Spindle pitch = +0: Information refers to travelling distance in 1/100mm If the AG03 is beyond the range defined by limit 1 and limit 2 (travel range), travelling will only be possible in the direction of the travel range in inching mode. Achtung! Limit monitoring is deactivated if 'limit 1' is equal 'limit 2'. Please note that there is a jump of the actual position if the resolution of the absolute encoder is exceeded!!! Velocity mode: no meaning <i>CAN-Bus chapter 7.12.2: object 607D_h P sub-index 02_h</i>
16	Litmit 2 **	-9999999 to 9999999	-1000000	Positioning mode: Litmit 2 Spindle pitch = 0: Information refers to increments Spindle pitch = +0: Information refers to travelling distance in 1/100mm If the AG03 is beyond the range defined by limit 1 and limit 2 (travel range), travelling will only be possible in the direction of the travel range in inching mode. Achtung! Limit monitoring is deactivated if 'limit 1' is equal 'limit 2'. Please note that there is a jump of the actual position if the resolution of the absolute encoder is exceeded! Velocity mode: no meaning <i>CAN-Bus chapter 7.12.2: object 607D_h P sub-index 01_h</i>
17	Delta Inch **	-1000000 to 1000000	1600	Delta travelling distance with inching operation 1: indicates the relative travelling distance. positive value ⇒ positive travelling direction negative value ⇒ negative travelling direction Spindle pitch = 0: Information refers to increments Spindle pitch = +0: Information refers to travelling distance in 1/100 m <i>CAN-Bus chapter 7.12.2: object 2415_h</i>

Nr.	Name	Selection / value	Default	Description
18	Sense of rotation **	i, e	i	Counting direction of the measuring system: When the shaft rotates counter-clockwise (view on the clamping ring of the AG03). i sense of rotation: ⇒ positive counting direction e sense of rotation: ⇒ negative counting direction <i>CAN-Bus chapter 7.12.2: object 607E_h</i>
19	Pos Type **	direct loop + sloop -	direct	Positioning mode: Type of positioning <i>direct:</i> direct travelling from actual position to target value <i>loop +:</i> travelling to the target value occurs always in positive direction to compensate for spindle play <i>loop -:</i> travelling to the target value occurs always in negative direction to compensate for spindle play. Caution! Loop positioning in positioning mode only. Velocity mode: no meaning <i>CAN-Bus chapter 7.12.2: object 2413_h</i>
20	Operating mode **	positioning mode / speed mode	positioning mode	Positioning mode: <i>(see chapter 2.2.1: Positioning mode)</i> Velocity mode: <i>(see chapter 2.2.2: Velocity mode)</i> <i>CAN-Bus chapter 7.12.2: object 6060_h</i>
21				reserved
22				reserved
23				reserved
24	Setpoint **	see column 'Description'	0	Positioning mode: indicates absolute target position. Spindle pitch = 0: Information refers to increments Spindle pitch = +0: Information refers to travelling distance in 1/100 m Value range: depends on the pre-programmed target values (<i>parameters 15/16</i>) Velocity mode: indicates the target velocity in rev./min. Value range: gear ratio 48:1 ⇒ max. ±100 rev/min gear ratio 24:1 ⇒ max. ±200 rev/min <i>CAN-Bus see chapter 7.2.5: Transmit PDO's</i> Attention !!! Target value will not be stored in the EEPROM
25	Stop mode Inching mode 2 **	0/1	0	Stop mode inching mode 2 / touch button mode The stop behaviour of inching mode 2 or touch button operation can be parameterized in different ways. Stop mode = 0 stop with maximum delay Stop mode = 1 stop with pre-programmed delay (parameter no. 8) <i>CAN-Bus chapter 7.12.2: object 2416_h</i>
26	Inpos mode **	0/1/2	0	Operating mode: positioning mode: The drive's behaviour upon reaching the positioning window can be determined by this parameter: Inpos mode = 0 position control to setpoint value Inpos mode = 1 position control OFF and short circuit of motor windings Inpos mode = 2 position control OFF and release of drive Velocity mode: no meaning <i>CAN-Bus chapter 7.12.2: object 2417_h</i>

Nr.	Name	Selection / value	Default	Description
27	Loop length**	0 - 10000	800	Operating mode: positioning mode: Indicates the loop length in increments Velocity mode: no meaning <i>CAN-Bus chapter 7.12.2: object 2418_h</i>
28				reserved
29	Torque deactivation **	20 - 125	125	Operating mode: positioning mode: This parameter determines the threshold of torque deactivation. Percent values are to be entered. Value 125: Torque deactivation disabled. Velocity mode: no meaning <i>CAN-Bus chapter 7.12.2: object 2421_h</i>

Table 6: Parameter description

7 Communication via CAN bus

7.1 General remarks

This chapter describes activation and parameterization via CAN bus interface.
For the connector pin assignment of the CAN bus interface please refer to the user information.

7.1.1 Interface

The AG03 supports the following baud rates:

- 15.625 kBd, 20 kBd, 25 kBd, 40 kBd, 50 kBd, 62.5 kBd, 100 kBd, 125 kBd, 200 kBd, 250 kbd, 500 kBd, 1000 kBd

Termination of the CAN bus line:

If the AG03 is at the end of the bus, the CAN bus connection must be terminated by a defined bus terminator. For the AG03 this is achieved by means of an internal terminating resistor which can be switched in via DIP switches SW9 + SW10 (see chapter 7.14: CAN bus terminator).

7.2 CANopen protocol

The CANopen protocol is based on the CANopen communication profile *CiA DS-301 V4.0* as well as the device profile *Drives and Motion Control CiA DSP-402 V2.0*.

The details required for a better understanding and possible deviations are included in this documentation.

7.2.1 Telegram setup

The data telegram of a CAN message consists of the following fields:

SOF:

Start of Frame ⇒ start bit of the telegram

Identifier:

The Identifier field contains the identifier as well as bits for the recognition of the length of the identifiers (11 or 29 bits). The identifier determines the priority of the message.

Via identifier, CANopen determines additionally the device address, channel selection as well as data direction.

Control field:

contains bits concerning the number of user data and determines whether a data frame or RTR frame (Remote Transfer Request frame) is concerned.

Data field:

contains up to 8 bytes of user data. The user data has a different meaning depending on the channel selection.

CRC:

contains bits for error detection.

ACK/EOF:

The ACK/EOF field contains telegram acknowledgement bits as well as bits for determining the end of telegram.



Fig. 15: Telegram setup

For a detailed description of the telegram please refer to the comprehensive CAN literature. For simplification, only identifier and data field will be dealt with in the subsequent telegram descriptions.

7.2.2 Network management (NMT)

The master configures, manages and monitors network nodes via the NMT service.

For switching between the four available communication states of a network node, 'INITIALISATION', 'PRE-OPERATIONAL', 'OPERATIONAL' and 'STOPPED', telegrams with the identifier '0' as well as 2 bytes of user data are used.

The identifier of the NMT protocol is limited to 11 bits.

7.2.2.1 State Diagramm

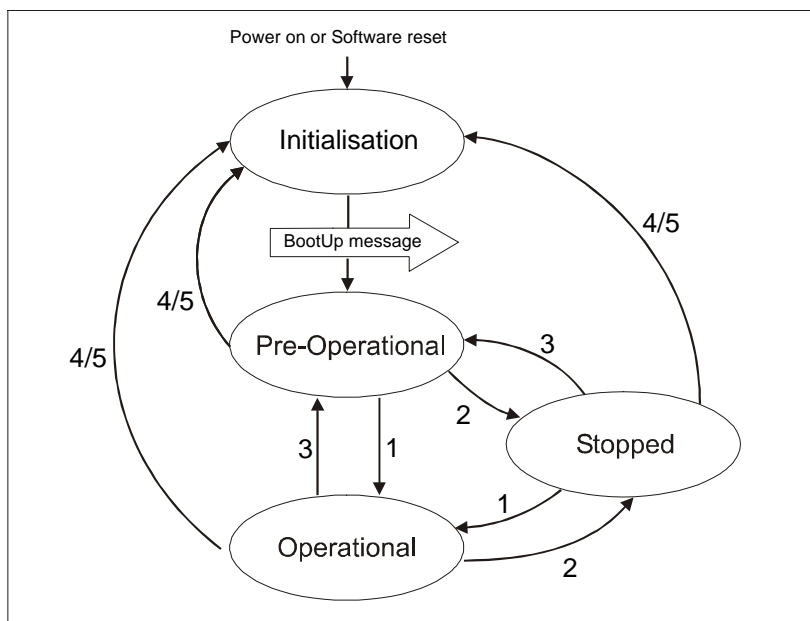

Fig. 16: State Diagramm

7.2.2.2 NMT Status 'INITIALISATION'

The AG03 is not involved in the bus actions in this state. All hardware and software components are initialised. This state is attained after switching on the device or after receipt of the command code 82h of the own or global addresses. After completion of initialisation, the AG03 goes automatically into the 'PRE-OPERATIONAL' status. This is signalled by a boot-up message consisting of the identifier '1791 + Node ID' and a data byte having the value '0'.

7.2.2.3 NMT Status 'PRE-OPERATIONAL'

The exchange of parameterization data (SDOs) between the AG03 and the bus master is enabled. However, no process data (PDOs) is transferred. Furthermore, the State Machine of the AG03 is set to the 'SWITCH ON DISABLED' state (see chapter 7.3) and the motor enabled.



PDO parameters can be changed in this state only!

7.2.2.4 NMT Status 'OPERATIONAL'

Exchange of process and parameterization data is enabled.

7.2.2.5 NMT Status 'STOPPED'

Exchange of all data is stopped with the exception of the heartbeat message (see chapter 7.2.10) and the node guarding protocol, if active (see chapter 7.2.11). Only NMT communication is enabled.

Furthermore, the State Machine of the AG03 is set to the 'SWITCH ON DISABLED' state (see chapter 7.3) and the motor enabled.

7.2.2.6 Switching between communication states

The network master can switch between the communication states by sending the following telegrams with the identifier '0'.

Status change		Data 1	Data 2
from	to		
PRE-OPERATIONAL / STOPPED	OPERATIONAL (1)	01h	xx
OPERATIONAL / PRE-OPERATIONAL	STOPPED (2)	02h	xx
OPERATIONAL / STOPPED	PRE-OPERATIONAL (3)	80h	xx
OPERATIONAL / PRE-OPERATIONAL / STOPPED	INITIALISATION (4/5)	81h	xx
OPERATIONAL / PRE-OPERATIONAL / STOPPED	INITIALISATION * (4/5)	82h	xx

Table 17: Switching between communication states

* Cold start is triggered (power on)

xx = 0 ⇒ the telegram is intended for all devices on the bus
 xx = device address ⇒ the telegram is only intended for the device with the respective address.

7.2.3 SYNC object

CANopen enables the simultaneous query of all inputs and the simultaneous setting of all outputs. The synchronization telegram (SYNC), a CAN message with high priority, which contains no user data serves for this purpose.

The identifier of the Sync object can be set via object 1005_h (see chapter 7.12.2: Description of objects).

7.2.4 Process Data Objects (PDOs)

Process data objects serve for fast exchange of short process data. Process data objects are transferred event-triggered, cyclically or on request.

A maximum of 8 bytes of user data can be transferred in a PDO.



The exchange of PDOs is enabled in the NMT status 'OPERATIONAL' only!

The AG03 provides 3 Transmit PDOs (process data from the AG03 ⇒ NMT master) and 3 Receive PDOs (process data from the NMT master ⇒ to the AG03).

The Receive PDOs, RPDO1, RPDO3, RPDo4 and the Transmit PDOs, TPDO1, TPDO3 and TPDO4 are supported according to the Device Profil 'Drives and Motion Control CIA DSP-402 Version 2.0'.

7.2.5 Transmit PDOs

7.2.5.1 1st Transmit PDO (TPDO1)

The first Transmit PDO contains 2 user data bytes on which the status word of the AG03 is mapped.

The Transmit PDO is transferred by the AG03 asynchronously as a standard. Together with the Receive PDO1 on which the control word of the state machine is mapped it forms a handshake connection (acknowledgement operation) between the higher-order control and the drive controller.

It is, therefore not recommended to change the transfer type of the TDO1.

The COB-ID of the first Transmit PDO is programmed to $180_h + \text{Node-ID}$ by default. The communication parameters are set via the object 1800_h (1st Transmit PDO parameter).

1 st Transmit PDO		
11 / 29 bit identifier	byte 1	byte 2
	LSB	MSB
	status word (object 6041_h)	

Fig. 17: 1st Transmit PDO

7.2.5.2 3rd Transmit PDO (TPDO3)

The third Transmit PDO contains 6 user data bytes on which the status word and the current position value of the AG03 are mapped.

The Transmit PDO3 is transferred only by a RTR frame (remote transfer request) as a standard, i.e., a higher-order control must request the TDO3 (polling). Synchronous transfer (value 0 to 240) can be set via the SYNC object or the time-triggered transfer (value 255) by means of a local cycle (event timer) as an alternative to polling.

The COB-ID of the third Transmit PDO is programmed to $380_h + \text{Node-ID}$ by default. The communication parameters are set via the object 1802_h (3rd Transmit PDO parameter).

3 rd Transmit PDO						
11/29 bit identifier	byte 1	byte 2	byte 3	byte 4	byte 5	byte 6
	LSB	MSB	LSB	NSB	NSB	MSB
	status word (object 6041_h)			position value (object 6064_h)		

Fig. 18: 3rd Transmit PDO

7.2.5.3 4th Transmit PDO (TPDO4)

The fourth Transmit PDO contains 6 user data bytes on which the status word and the actual velocity of the AG03 is mapped.

The Transmit PDO4 is transferred only by a RTR frame (remote transfer request) as a standard, i.e., a higher-order control must request the TDO4 (polling). Synchronous transfer (value 0 to 240) can be set via the SYNC object or the time-triggered transfer (value 255) by means of a local cycle (event timer) as an alternative to polling.

The COB-ID of the fourth Transmit PDO is programmed to $480_h + \text{Node-ID}$ by default. The communication parameters are set via the object 1803_h (4th Transmit PDO parameter).

4 th Transmit PDO						
11/29 bit identifier	byte 1	byte 2	byte 3	byte 4	byte 5	byte 6
	LSB	MSB	LSB	NSB	NSB	MSB
	status word (object 6041 _h)			actual velocity (object 606C _h)		

Fig. 19: 4th Transmit PDO

7.2.5.4 Transfer types of the Transmit PDOs

Different transfer types can be set for the individual PDOs via objects 1800_h until 1803_h 'Transmit PDO Parameter' sub-index 2 (see chapter 7.12.2: Objects of the AG03).

Synchronous:

Sub-index 2 (transfer type) = 0:

The Transmit PDO is sent by the AG03 upon receipt of each SYNC telegram.

Sub-index 2 (transfer type) = 1...240:

The Transmit PDO is sent by the AG03 only after receipt of the number of SYNC telegrams indicated under 'transfer type'.

Asynchronous:

Event-Triggered: Sub-index 2 (transfer type) = 254:

A PDO is sent with every change of the position value (Profile Position Mode) or the actual velocity (Profile Velocity Mode), respectively (only possible with TPDO3 and TPDO4).

Time-Triggered: Sub-index 2 (transfer type) = 255:

The PDOs are transferred time-triggered.

The sub-index 5 'Event Timer' of the Transmit PDO parameters indicates the cycle time in milliseconds.

Sub-index 2 (transfer type) = 253:

The Transmit PDO is sent after receipt of a RTR frame with the identifier of the respective Transmit PDO.

7.2.6 Receive PDOs

7.2.6.1 1st Receive PDO (RPDO1)

The first Receive PDO contains 2 user data bytes on which the status word of the AG03 is mapped.

The control word in the Receive PDO1 serves for controlling the operation transitions of the state machine. The Receive PDO1 serves for getting the state machine into the OPERATION ENABLED state or for commanding travel interruption or cancellation of travel during running drive movement, respectively.

The drive controller processes the Receive PDO1 asynchronously as a standard. Together with the Transmit PDO1 on which the control word of the state machine is mapped it forms a handshake connection (acknowledgement operation) between the higher-order control and the drive controller.

It is, therefore not recommended to change the transfer type of the RPDO1.

The COB-ID of the first Receive PDO is programmed to 200_h + Node-ID by default.

The communication parameters are set via the object 1400_h (1st Receive PDO parameter).

1 st Receive PDO		
11 / 29 bit identifier	byte 1	byte 2
	LSB	MSB
	control word (object 6040 _h)	

Fig. 20: 1st Receive PDO

7.2.6.2 3rd Receive PDO (RPDO3)

The third Receive PDO is assigned to the operation mode 'Profile Position Mode' (positioning mode) and contains 6 user data bytes on which the control word as well as the current target value for the AG03 is mapped.

The position transferred is taken over as the absolute target position. Drive movement in the positioning mode can be executed from the 'OPERATION ENABLED' state of the state machine only.

The drive controller processes the Receive PDO3 asynchronously as a standard.

Together with the Transmit PDO1 on which the status word of the state machine is mapped, it forms a handshake connection (acknowledgement operation) between the higher-order control and the drive controller.

Synchronous transfer type (value 0) can be set to enable synchronous start of more than one drive. The data of the RPDO3 is processed only after receipt of the next SYNC telegram in this case (see chapter 10.2.3: Sync object).

The COB-ID of the third Transmit PDO is programmed to 400_h + Node-ID by default.

The communication parameters are set via the object 1402_h (3rd Receive PDO parameter).

3 rd Receive PDO						
11/29 bit identifier	byte 1	byte 2	byte 3	byte 4	byte 5	byte 6
	LSB	MSB	LSB	NSB	NSB	MSB
	control word (object 6040 _h)			target value (object 607A _h)		

Fig. 21: 3rd Receive PDO

7.2.6.3 4th Receive PDO (RPDO4)

The fourth Receive PDO is assigned to the operation mode 'Velocity Mode' and contains 6 user data bytes on which the control word as well as the current target velocity for the AG03 are mapped.

A driving movement in positive or negative sense of rotation is started via the control word in the Receive PDO4. Drive movement in the velocity mode can be executed from the 'OPERATION ENABLED' state of the state machine only.

The drive controller processes the Receive PDO4 asynchronously as a standard.

Together with the Transmit PDO1 onto which the status word of the state machine is mapped, it forms a handshake connection (acknowledgement operation) between the higher-order control and the drive controller.

Synchronous transfer type (value 0) can be set to enable synchronous start of more than one drive. The data of the RPDO4 is processed only after receipt of the next SYNC telegram in this case (see chapter 7.2.3: Sync object).

The COB-ID of the fourth Transmit PDO is programmed to 500_h + Node-ID by default.

The communication parameters are set via the object 1403_h (4th Receive PDO parameter).

4 th Receive PDO						
11/29 bit identifier	byte 1	byte 2	byte 3	byte 4	byte 5	byte 6
	LSB	MSB	LSB	NSB	NSB	MSB
	control word (object 6040 _h)			target velocity (object 60FF _h)		

Fig. 22: 4th Receive PDO

7.2.6.4 Transfer types of the Receive PDOs

Different transfer types can be set for the individual PDOs via objects 1400_h until 1403_h 'Receive PDO Parameter' sub-index 2 (see chapter 7.12.2: Description of objects).

Synchronous:

Sub-index 2 (transfer type) = 0...240

In the synchronous transfer type, the Receive PDOs are processed only after receipt of a SYNC telegram.

Asynchronous:

Sub-index 2 (transfer type) = 254...255

In the asynchronous transfer type, the Receive PDOs are processed by the AG03 immediately after receipt of the Receive PDO.

7.2.7 Service Data Objects (SDOs)

Service Data Objects (SDOs) serve in the first place for transferring device configuration parameters.

8 bytes of user data are always transferred in a SDO. The identifier is set to 11 bits and cannot be changed.



The exchange of SDOs is enabled in the NMT statuses 'PRE-OPERATIONAL' as well as 'OPERATIONAL'!

There is each one COB ID for data transfer from the master to the AG03 (COB-ID 600_h + Node ID) and one COB ID for data transfer from the AG03 to the master (COB-ID 580_h + Node-ID).

Data transfer is always initiated and controlled by the master.

The COB IDs for the Service Data Objects cannot be changed.

SDO-Telegramm								
11 bit identifier	byte 1	byte 2	byte 3	byte 4	byte 5	byte 6	byte 7	byte 8
	command	parameter index	sub-index	data 1	data 2	data 3	data 4	

Fig. 23: Setup of the SDO telegram

Byte 1: Command code

The first byte contains the command code of the SDO telegram. The following table lists the available commands and describes their meaning.

Command	Command code hexadecimal	Command code decimal	Meaning
Write Request	23 _h	35	send parameters to the AG03 (4 data byte)
Write Request	2B _h	43	send parameters to the AG03 (2 data byte)
Write Request	2F _h	47	send parameters to the AG03 (1 data byte)
Write Response	60 _h	96	response of the AG03 to Write Request
Read Request	40 _h	64	request of a parameter by the AG03
Read Response	43 _h	67	response to the request (4 data byte)
Read Response	4B _h	75	response to the request (2 data byte)
Read Response	4F _h	79	response to the request (1 data byte)
Error Response	80 _h	128	error message

Table 18: Command codes

Bytes 2/3: Parameter index

The parameter index is entered in the user data byte 2 (low byte) and in the user data byte 3 (high byte) using their Intel data format.

Here, the index of the object to be parameterized is entered (see chapter 7.12.2: Description of objects).

Byte 4: Sub-index

The sub-index indicates the number of the fields for objects realized as an array.

Bytes 5...8: Data area

In the data area, the value of the parameter is entered in left-aligned Intel notation.

Byte 5 = low-Byte ... Byte 8 = high Byte

7.2.7.1 Error code

The AG03 sends an error response (byte 1 = 80_h) if a communication error has occurred. An error code is entered in the user data bytes (bytes 5 ... 8).

The table below shows the supported error codes of the AG03.

Command code	Data 1	Data 2	Data 3	Data 4	Meaning
80 _h	11 _h	00 _h	09 _h	06 _h	Sub-index does not exist.
80 _h	02 _h	00 _h	01 _h	06 _h	Attempt to write read-only object.
80 _h	01 _h	00 _h	01 _h	06 _h	Attempt to read write-only object.
80 _h	30 _h	00 _h	09 _h	06 _h	Value range of parameter exceeded.
80 _h	36 _h	00 _h	09 _h	06 _h	Maximum value is less than minimum value.
80 _h	00 _h	00 _h	02 _h	06 _h	Object does not exist.
80 _h	00 _h	00 _h	01 _h	06 _h	Unsupported access to an object.
80 _h	22 _h	00 _h	00 _h	08 _h	Data cannot be transferred to the application because of the present device state.

Table 19: Error codes

7.2.8 Example: Parameterization

The following 2 examples are intended to illustrate parameterization of the AG03 via Service Data Objects.



7.2.8.1 Example: Read parameter

The AG03 has device address 5 and the calibration value is to be read out!

Calculation of the identifier:

Identifier of the parameter channel to the AG03 = $600_h + \text{device address}$

$$600_h = 1536_{\text{dec}}$$

$$\text{Identifier} = 1536 + 5 = 1541 = 605_h$$

Command code = Read request (= request of a parameter from the AG03) = 40_h .

$$\text{Index} = 607C_h .$$

The index of the parameter 'Calibration value was taken from the directory of objects (*chapter 7.12.2: Description of objects*).

Sub-index = 0

The current calibration value is $2500 = 9C4_h$.

Telegram from the master to the AG03:

Identifier	Byte 1	Byte 2	Byte 3	Byte 4	Byte 5	Byte 6	Byte 7	Byte 8
605_h	40_h	$7C_h$	60_h	00_h	00_h	00_h	00_h	00_h

Response of the AG03:

Identifier	Byte 1	Byte 2	Byte 3	Byte 4	Byte 5	Byte 6	Byte 7	Byte 8
585_h	42_h	$7C_h$	60_h	00_h	$C4_h$	09_h	00_h	00_h

Command code = Read Response = 42_h

Calculation of the identifier:

Identifier of the parameter channel from the AG03 to the master = $580_h + \text{device address}$

$$580_h = 1408_{\text{dec}}$$

$$\text{Identifier} = 1408 + 5 = 1413 = 585_h$$

7.2.8.2 Example: Write parameter

For the AG03 with device address 5 the limit 1 is to be set to 2000000!

Calculation of the identifier:

Identifier of the parameter channel to the AG03 = $600_h + \text{device address}$

$$600_h = 1536_{\text{dec}}$$

$$\text{Identifier} = 1536 + 5 = 1541 = 605_h$$

Command code = Write request (send parameter to the AG03) = 23_h

$$\text{Index} = 607D_h .$$

Sub-index = 2

The index and the sub-index of the parameter 'limit 1' were taken from the directory of objects (*chapter 7.12.2: Description of objects*).

$$2000000 = 1E8480_h$$

Telegram from the master to the AG03:

Identifier	Byte 1	Byte 2	Byte 3	Byte 4	Byte 5	Byte 6	Byte 7	Byte 8
605 _h	23 _h	7D _h	60 _h	02 _h	80 _h	84 _h	1E _h	00 _h

Response of the AG03 in the case of error-free execution:

Identifier	Byte 1	Byte 2	Byte 3	Byte 4	Byte 5	Byte 6	Byte 7	Byte 8
585 _h	60 _h	7D _h	60 _h	02 _h	00 _h	00 _h	00 _h	00 _h

Command code = Write Response = 60_h

Calculation of the identifier:

Identifier of the parameter channel from the AG03 to the master = 580_h + device address

$$580_{\text{h}} = 1408_{\text{dec}}$$

$$\text{Identifier} = 1408 + 5 = 1413 = 585_{\text{h}}$$

7.2.9 Emergency Object (EMCY)

In the case of an error, the node status is transferred via high-priority emergency messages (emergency telegrams). These telegrams have a data length of 8 bytes and contain error information.

The emergency telegram is transferred as soon as the AG03 goes into the fault state (*for the causes of faults refer to chapter 5.2: Faults*) or when a communication error has occurred (*see table 20 Error codes 8001 – 8120*).

Resolution of the cause of fault and resetting of the AG03 with undoing the fault state are signalled by sending of an emergency telegram with the error code 0000_h (no error) (not applicable to communication errors ⇒ Error codes 8001 – 8021).

The cause of the fault is deposited in the fault buffer (*see object 1003_h*).

Setup of the emergency telegram.

Identifier	Byte 0	Byte 1	Byte 2	Byte 3	Byte 4	Byte 5	Byte 6	Byte 7
11/29 Bit	Emergency Error Code (see chapter 7.2.9.1)		Error Register (Object 1001 _h)	Manufacturer-specific error field (not used)				

Fig. 24: Emergency protocol

The identifier of the emergency object is set to 128 + Node-ID by default; however, it can be changed via object 1014_h (*see chapter 7.12.2: Description of objects*).

Transfer of an emergency telegram is enabled in the NMT statuses 'OPERATIONAL' or 'PRE-OPERATIONAL' only!

7.2.9.1 Error Code

The following table contains the possible error codes of the emergency telegram:

Error Code		Meaning
Byte 0 (Highbyte)	Byte 1 (Lowbyte)	
00	00 _h	No error (no fault present) Is sent after clearing the fault state. (see chapter 5.2: Faults)

Error Code		Meaning
Byte 0 (Highbyte)	Byte 1 (Lowbyte)	
21	00 _h	Current on device input side (<i>overcurrent: see chapter 5.2.1 P value 'C'</i>) The state machine was set to the 'Fault' state. Fault is deposited in the fault buffer.
31	20 _h	Mains under voltage (<i>Undervoltage: see chapter 5.2.1 P value 'A'</i>) The state machine was set to the 'Fault' state. Fault is deposited in the fault buffer.
32	10 _h	DC link over-voltage (<i>Overvoltage: see chapter 5.2.1 P value 'G'</i>) The state machine was set to the 'Fault' state. Fault is deposited in the fault buffer.
43	10 _h	Excess temperature drive (<i>Overtemperature in output stage: see chapter 5.2.1 P value 'D'</i>) The state machine was set to the 'Fault' state. Fault is deposited in the fault buffer.
71	21 _h	Motor blocked (<i>Drive shaft blocked: see chapter 5.2.1 P value 'B'</i>) The state machine was set to the 'Fault' state. Fault is deposited in the fault buffer.
80	01 _h	Bus Error Ack: The message transferred has not been acknowledged by another node. Is not deposited in the fault buffer.
80	02 _h	Bus Error Form: A portion of the telegram received has the wrong format. Is not deposited in the fault buffer.
80	03 _h	Bus Error CRC: The checksum of the cyclical block check is incorrect. Is not deposited in the fault buffer.
80	04 _h	Bus Error Stuff: More than 5 equal bits in a row are present in a portion of the telegram received where this is not permitted. Is not deposited in the fault buffer.
81	20 _h	The bus status has changed to 'Error Passive' mode. Communication via CANopen is no longer enabled! Will not be stored in the failure buffer.
FF	00 _h	Manufacturer-specific reserved
FF	01 _h	Manufacturer-specific (<i>Internal error: see chapter 5.2.1 P value 'F'</i>) The state machine is set to the 'Fault' state. Fault is deposited in the fault buffer.
FF	02 _h	Manufacturer-specific During active positioning, the bus status 'Error Passive' has occurred. The State Machine was set to the 'Fault' state. Cause of failure is stored in the failure buffer. <i>See chapter 5.2.1. P value 'H'.</i> Communication via CANopen is no longer enabled!
FF	03 _h	Manufacturer-specific Bus Status has changed to 'Bus Off' The State Machine was set to the 'Fault' state. Cause of failure is stored in the failure buffer. <i>See chapter 5.2.1. P value 'I'.</i> Communication via CANopen is no longer enabled!

Tab. 20: Error Code

7.2.10 Heartbeat protocol

The master monitors the state of the AG03 via heartbeat protocol. While doing this, the AG03 sends cyclically its NMT status.

The AG03 sends the heartbeat telegram independently, without request via RTR frame. The AG03 is a heartbeat producer, it does not receive nor process heartbeat protocols.

The cycle time of the heartbeat telegram is set via object 1017_h (see chapter 7.12.1: Objects of the AG03).

The heartbeat protocol is deactivated if the cycle time is 0.

The heartbeat protocol consists of one byte.

Identifier	Byte1
11 bit	status

Fig. 25: Heartbeat protocol

Status = 0: 'INITIALISATION'
 Status = 4: 'STOPPED'
 Status = 5: 'OPERATIONAL'
 Status = 127: 'PRE-OPERATIONAL'

The identifier of the heartbeat protocol is permanently set to 1792 + Node-ID and cannot be changed.

Heartbeat telegram are sent in the NMT statuses 'OPERATIONAL', 'PRE-OPERATIONAL' or 'STOPPED'.



The heartbeat protocol is only enabled when node guarding is deactivated!

7.2.11 Node Guarding

Node-guarding or life-guarding mechanisms are available for failure monitoring of the CANopen network. Via node guarding the nodes are monitored that can detect a failure of the master. During guarding, the master transmits remote frames (remot transmit request, message request telegrams) on the guarding identifiers of the nodes to be monitored. The latter respond with the guarding message containing the current status of the slave as well as a toggle bit which must change after each message.

The master assumes that a node error as occurred if status or toggle bits do not correspond with those expected by the master.

Via the objects 100C_h (Guard Time), 100D_h (Life Time Factor) the time interval (life time) is set within which the AG03 expects a node query (RTR frame with the COB-ID 1792 + Node-ID) by the NMT master.

The time interval 'Life time' is calculated from the cycle time 'Guard time' multiplied with the factor 'Life Time Factor'.

The AG03 State Machine switches to the 'SWITCH ON DISABLED' state if the AG03 receives no RTR frame from the master during the 'Life Time'.

By sending the first RTR frame of the master to the AG03, Node Guarding of the AG03 is activated after switching on.

Node Guarding is deactivated if the value of either object (100C_h/100D_h) is zero.

The response of the AG03 to the RTR frame of the master consists of one byte of user data.

Identifier	Byte 1	
11 bit	bit 7: toggle Bit	bit 6 ... 0: status

Fig. 26: Node-Guarding Telegram

Toggle Bit:

The toggle bit must alternate between two subsequent responses of the AG03. The value of the toggle bit with the first response of the AG03 is 0 after activation of the guarding protocol.

Status:

Status = 0: 'INITIALISATION'
 Status = 4: 'STOPPED'
 Status = 5: 'OPERATIONAL'
 Status = 127: 'PRE-OPERATIONAL'

The identifier of the heartbeat protocol is permanently set to 1792 + Node-ID and cannot be changed.

A node guard telegram can be sent in the NMT statuses 'OPERATIONAL', 'PRE-OPERATIONAL' or 'STOPPED'.



The node-guard protocol is only enabled when the heartbeat protocol is deactivated!

7.3 State Machine

In the status word, the CANopen state machine indicates operational and error states of the drive resulting from operational transitions.

The states of the state machine can change via control word (see chapter 7.5) or due to internal events (e.g., occurrence of a fault). The current state of the state machine can be read via the status word (see chapter 7.4: Table 22).



The states of the state machine can be set via PDOs only!

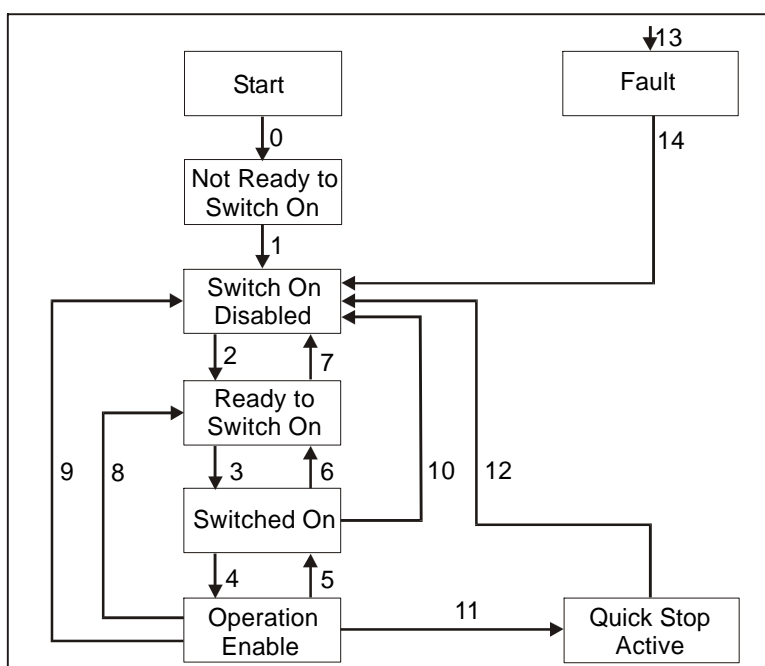

Fig. 27: State machine



The following states of the state machine of the AG03 are available:

- 'NOT READY TO SWITCH ON'
The AG03 is being initialized after switching on.
No travel commands can be accepted.
Motor is enabled
- 'SWITCH ON DISABLED'
Initialization completed.
No travel commands can be accepted.
Motor is enabled
- 'READY TO SWITCH ON'
No travel commands can be accepted.
Motor is enabled
- 'SWITCHED ON'
No travel commands can be accepted.
Motor is enabled
- 'OPERATION ENABLED'
Travel commands can be accepted.
Motor is in control state.
- 'QUICK STOP ACTIVE'
The Quick Stop command was executed.
Motor decelerates with maximum deceleration and stops with stop torque.
Current positioning is cancelled.
No travel commands can be accepted.
- 'FAULT'
An error has occurred.
Motor is enabled
Current positioning is cancelled.
No travel commands can be accepted.

The states of the State Machine can be changed via internal events or through commands of the master via control word (see *table 24*).

- State change 0: START ⇒ NOT READY TO SWITCH ON
Power on or software reset of the AG03
- State change 1: NOT READY TO SWITCH ON ⇒ SWITCH ON DISABLED
Initialization and self-test of the AG03 successfully completed.
- State change 2: SWITCH ON DISABLED ⇒ READY TO SWITCH ON
'Shut-down' command by master
- State change 3: READY TO SWITCH ON ⇒ SWITCHED ON
'Switch-On' command by master
- State change 4: SWITCHED ON ⇒ OPERATION ENABLE
'Enable Operation' command by master
- State change 5: OPERATION ENABLE ⇒ SWITCHED ON
'Disable Operation' command by master
- State change 6: SWITCHED ON ⇒ READY TO SWITCH ON
'Shut-down' command by master



- State change 7: READY TO SWITCH ON ⇒ SWITCH ON DISABLED
'Disable Voltage' command by master
- State change 8: OPERATION ENABLE ⇒ READY TO SWITCH ON
'Shut-down' command by master
- State change 9: OPERATION ENABLE ⇒ SWITCH ON DISABLED
'Disable Voltage' command by master
- State change 10: SWITCHED ON ⇒ SWITCH ON DISABLED
'Disable Voltage' command by master
- State change 11: OPERATION ENABLE ⇒ QUICK STOP ACTIVE
'Quick-Stop' command by master
- State change 12: QUICK STOP ACTIVE ⇒ SWITCH ON DISABLED
'Disable Voltage' command by master
- State change 13: All states ⇒ FAULT
A fault has occurred
- State change 14: FAULT ⇒ SWITCH ON DISABLED
'Fault Reset' command by master

7.4 Status word

The status word reflects the current status of the AG03. It consists of 16 bits and is mapped on object 6041_h and on the 3 Transmit PDO's.

Status word																
15	14	13	12	11	10	9	8	7	6	5	4	3	2	1	0	
MSB								Low Byte								LSB

Fig. 28: Status word

The following table lists the designations of the individual bits of the status word and their meanings.

Bit	Designation	Description
0	Ready to switch on	indicates the state of the State Machine (see table 22)
1	Switched on	indicates the state of the State Machine (see table 22)
2	Operation enabled	indicates the state of the State Machine (see table 22)
3	Fault	indicates the state of the State Machine (see table 22)
4	Voltage enabled	bit 4 is set when the supply voltage is within the tolerance limit
5	Quick stop	indicates the state of the State Machine (see table 22) bit 5 is set when the AG03 is not in the 'QUICK STOP ACTIVE' state.
6	Switch on disabled	indicates the state of the State Machine (see table 22)
7	Warning	bit 7 is set when a warning is active (see chapter 5.1: Warnings).
8	Profile Position Mode: show readiness for travel	bit 8 is set if the State Machine is in the 'OPERATION ENABLED' state und the following conditions are met: <ul style="list-style-type: none"> • no fault present • the enable input is active • no limit have been exceeded • no active travel job

Bit	Designation	Description
	Profile Velocity Mode: show readiness for travel	Bit 8 is set if the State Machine is in the 'OPERATION ENABLED' state und the follwing conditions are met: <ul style="list-style-type: none"> no fault present no active travel job the enable input is active
9	Remote	Bit 9 is set when the AG03 is in the NMT status 'OPERATIONAL' or 'STOPPED'. The AG03 receives commands via CAN interface in this case.
10	Profile Position Mode: Target reached	Bit 10 is set when the drive has come to a stop at the pre-defined target position within the defined window after a successfully executed positioning command.
	Profile Velocity Mode: Target reached	Bit 10 is set when the actual speed is within the defined window of the target speed.
11	internal Limit	Bit 11 is set when the upper or lower limits have been exceeded.
12	Profile Position Mode: Set Point Acknowledged	Bit 12 is set when the drive controller has started a travel command in the positioning mode. A travel job is started via bit 'New Setpoint' in the control word (<i>object 6040h, control word bit 4</i>) (value 0 ⇒ 1). Subsequently, the controller firmware plausibilizes the target position, the operation and control parameters and the local state of the drive and sets bit 12 after the check has been passed successfully. Bit 12 is deleted when bit 4 in the control word has been reset to zero following a positioning job (Clear new setpoint).
	Profile Velocity Mode: Speed	Bit 12 is set when the drive stands still.
13	reserved	statically on 0
14	Profile Position Mode: Pos active	Bit 14 is set when there is an active positioning job in the operation mode 'Profile Position Mode' (positioning mode). Attention! No new setpoint is accepted and travelling in inching operation is disabled as long as bit 14 is set!
	Profile Velocity Mode:	no meaning, statically on 0
15	Profile Position Mode: drive travels	The drive shaft of the AG03 is moving if bit 15 is set.
	Profile Velocity Mode:	statically on 0

Table 21: Bit description of the status word

The following table represents the possible states of the state machine and the resulting bit values.

The field containing an x are irrelevant for the states of the state machine.

State	Bit 7	Bit 6	Bit 5	Bit 4	Bit 3	Bit 2	Bit 1	Bit 0
Not Ready to Switch On	x	0	x	x	0	0	0	0
Switch On Disabled	x	1	x	x	0	0	0	0
Ready to Switch On	x	0	1	x	0	0	0	1
Switched On	x	0	1	x	0	0	1	1
Operation Enabled	x	0	1	x	0	1	1	1
Quick Stop Activ	x	0	0	x	0	1	1	1
Fault	x	0	x	x	1	0	0	0

Table 22: Low byte status word States of the state machine

7.5 Control word

The control word consists of 16 bits and is mapped on the object 6040_h, and in the 3 Receive PDOs.

It contains bits for controlling the state machine as well as controlling the operational modes, Profile Position Mode (positioning mode) and Profile Velocity Mode (velocity mode).

Control word															
15	14	13	12	11	10	9	8	7	6	5	4	3	2	1	0
MSB								LSB							
High Byte								Low Byte							

Fig. 29: Control word

The following table lists the designations of the individual bits of the control word and their meanings.

Bit	Designation	Description
0	Switch on	controls the state of the State Machine (<i>see table 24</i>)
1	Disable voltage	controls the state of the State Machine (<i>see table 24</i>)
2	Quick stop	controls the state of the State Machine (<i>see table 24</i>)
3	Enable operation	controls the state of the State Machine (<i>see table 24</i>)
4	Profile Position Mode: New Setpoint	By bit 4, positioning is triggered in the drive controller in the OPERATION ENABLED state (value 0 \Rightarrow 1). The drive controller acknowledges the travel command via bit 12 'Setpoint acknowledged' in the status word (<i>see chapter 7.4</i>).
	Profile Velocity Mode:	no meaning
5	reserved	
6	reserved	
7	Fault reset	If the state machine of the AG03 is in the FAULT state, the fault is reset by an edge on bit 7 (0 \Rightarrow 1) and the state machine is set to the SWITCH ON DISABLED state on the condition that the cause of the fault has been resolved in advance (<i>see chapter 5.2: Faults</i>).
8	Profile Position Mode: Stop	By setting bit 8 on value 1, interruption of travel can be triggered during a running positioning event. Motor runs out with programmed deceleration and stops in the control state. Positioning is resumed and completed after resetting the bit (value 1 \Rightarrow 0).
	Profile Velocity Mode: Stop	By bit 8, drive movement is triggered in the velocity mode in the OPERATION ENABLED state (value 1 \Rightarrow 0).
9	reserved	
10	reserved	
11	reserved	
12	reserved	
13	Profile Position Mode: Inching operation 1	Inching operation 1 is started by an edge change (value 0 \Rightarrow 1) on bit 13 (<i>see chapter 2.2.1.2: Inching operation</i>).
	Profile Velocity Mode:	no meaning
14	Profile Position Mode: Inching operation 2 positive	Inching operation 2 is started in positive travel direction by an edge change (value 0 \Rightarrow 1) on bit 14 (<i>see chapter 2.2.1.2: Inching operation</i>). The drive travels in positive direction until bit 14 has been deleted.
	Profile Velocity Mode:	no meaning
15	Profile Position Mode: Inching operation 2 negative	Inching operation 2 is started in negative travel direction by an edge change (value 0 \Rightarrow 1) on bit 15 (<i>see chapter 2.2.1.2: Inching operation</i>). The drive travels in negative direction until bit 15 has been deleted.
	Profile Velocity Mode:	no meaning

Table 23: Bit description of the control word

The following table shows the control of the state machine with the bit combinations of the control word required.

The fields containing an x are irrelevant for the control of the state machine.

Command	Bit 7	Bit 6	Bit 5	Bit 4	Bit 3	Bit 2	Bit 1	Bit 0
Shutdown	0	x	x	x	x	1	1	0
Switch On	0	x	x	x	0	1	1	1
Disable Voltage	0	x	x	x	x	x	0	x
Quick Stop	0	x	x	x	x	0	1	x
Disable Operation	0	x	x	x	0	1	1	1
Enable Operation	0	x	x	x	1	1	1	1
Fault Reset	0 ⇒ 1	x	x	x	x	x	x	x

Table 24: Low Byte Control word_h control of state machine



- The states of the state machine can be changed via PDOs only.
- PDOs are enabled in the NMT status ,OPERATIONAL' only.
- Travel commands are enabled in the ,OPERATION ENABLED' state of the State machine.



7.6 Flowchart of the Profile Position Mode (positioning mode)

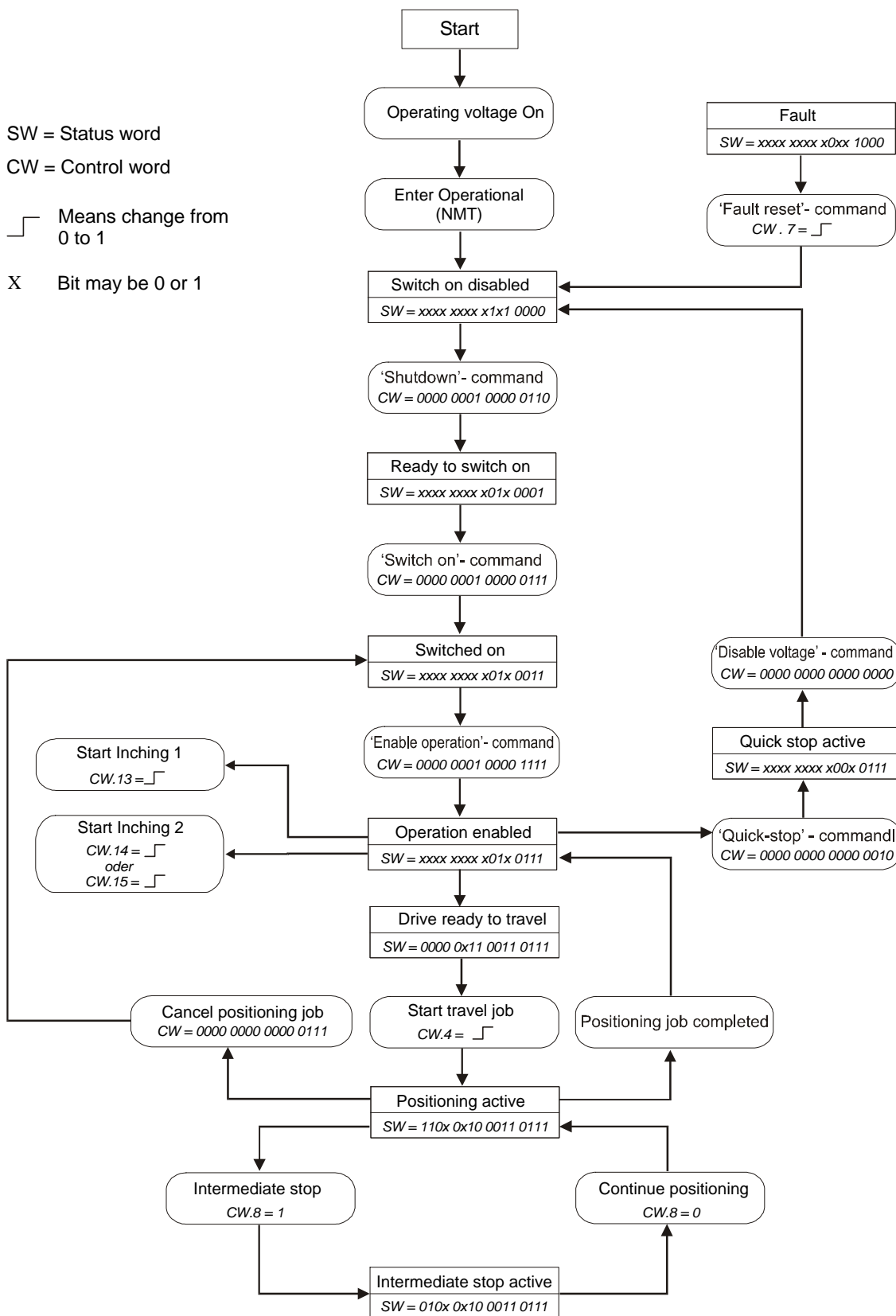

Fig. 30: Flowchart of the Profile Position Mode (positioning mode)



7.7 Flowchart of the Profile Velocity Mode operation mode (velocity mode)

SW = Status word
 CW = Control word

┐ Means change from 1 to 0

└ Means change from 0 to 1

X Bit may be 0 or 1

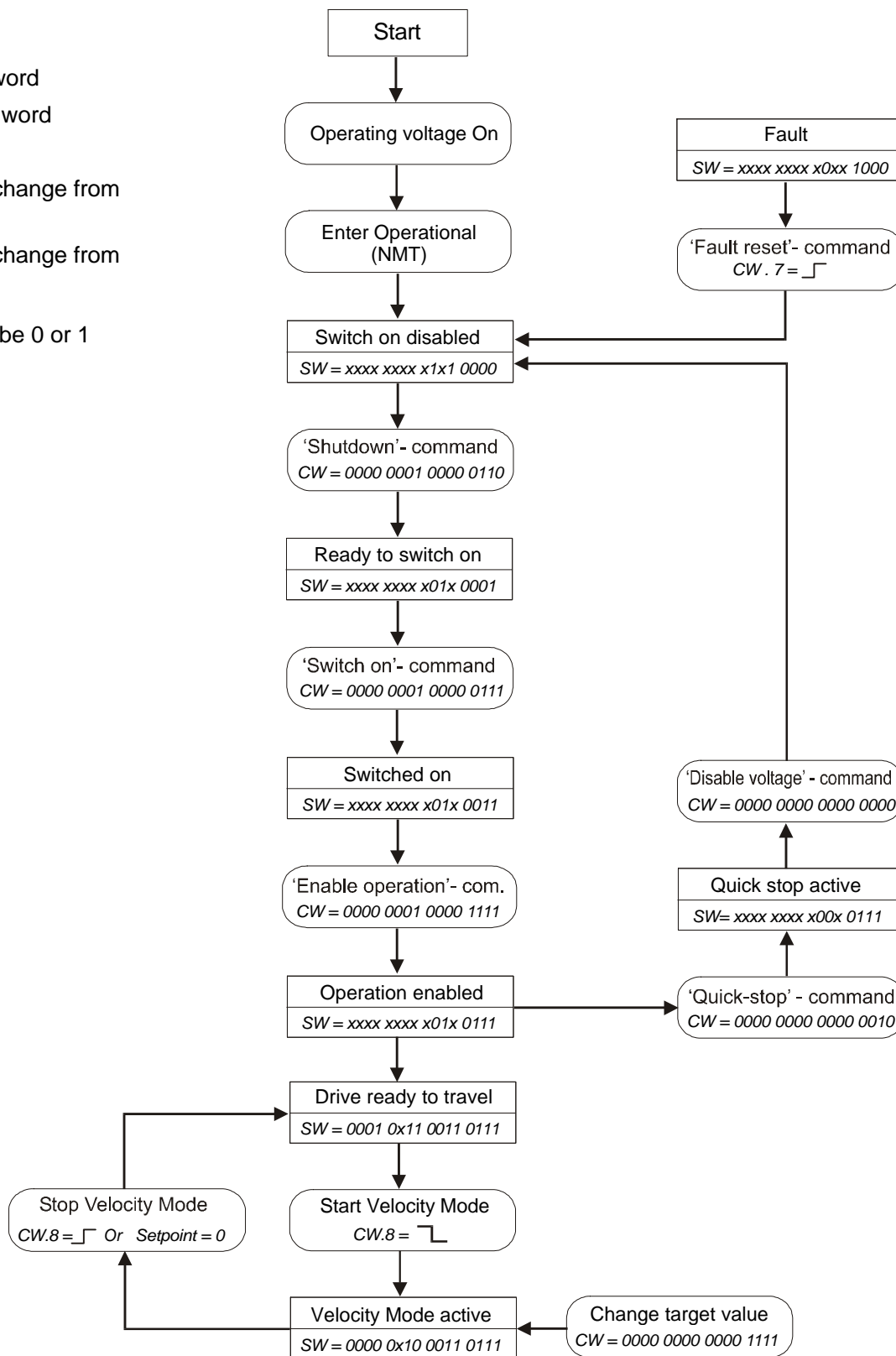

Fig. 31: Flowchart of the Profile Velocity Mode (velocity mode)

7.8 Examples

7.8.1 Example of the Profile Position Mode (positioning mode)

In the following table a positioning example in the Profile Position Mode (positioning mode) is represented.

The node address of the AG03 is 5 in this example.

Identifier	Message	Meaning
0x000	0x01 0x05	NMT: Enter OPERATIONAL
0x205	0x06 0x01	RPDO1: Shutdown command
0x205	0x07 0x01	RPDO1: Switch On command
0x205	0x0F 0x01	RPDO1: Enable Operation command
0x405	0x1F 0x00 0x88 0x13 0x00 0x00	RPDO3: Travel to position +5000
-	-	wait until target position has been reached
0x205	0x0F 0x01	RPDO1: clear New Setpoint
0x405	0x1F 0x00 0x78 0xEC 0xFF 0xFF	RPDO3: Travel to position -5000
0x205	0x1F 0x01	RPDO1: Intermediate stop
0x205	0x1F 0x00	RPDO1: continue positioning
-	-	wait until target position has been reached
0x205	0x0F 0x01	RPDO1: clear New Setpoint
0x205	0x07 0x01	RPDO1: Disable Operation command
0x205	0x06 0x01	RPDO1: Shutdown command
0x205	0x00 0x01	RPDO1: Disable Voltage command
0x000	0x80 0x05	NMT: Enter PRE-OPERATIONAL

Table 25: Positioning example in Profile Position Mode:

7.8.2 Example of the Profile Velocity Mode (velocity mode)

In the following table an example in the Profile Velocity Mode (velocity mode) is represented.

The node address of the AG03 is 5 in this example.

Operating mode change via parameter 20, chapter 6 parameter description (Default: Profile Position Mode).

Identifier	Message	Meaning
0x000	0x01 0x05	NMT: Enter OPERATIONAL
0x205	0x06 0x01	RPDO1: Shutdown command
0x205	0x07 0x01	RPDO1: Switch On command
0x205	0x0F 0x01	RPDO1: Enable Operation command
0x505	0x0F 0x00 0x44 0x00 0x00 0x00	RPDO4: Start of velocity mode with the target speed of +68 rev/min positive sense of rotation
-	-	wait until target speed has been reached
0x505	0x0F 0x00 0x1E 0x00 0x00 0x00	RPDO4: Change of velocity to +30 rev/min
0x205	0x0F 0x01	RPDO1: Stop drive movement
0x505	0x0F 0x00 0xB8 0xFF 0xFF 0xFF	RPDO4: Start of velocity mode with the target speed of -72 rev/min (negative sense of rotation)
-	-	wait until target speed has been reached
0x205	0x0F 0x01	RPDO1: Stop drive movement
0x205	0x07 0x01	RPDO1: Disable Operation command
0x205	0x06 0x01	RPDO1: Shutdown command
0x205	0x00 0x01	RPDO1: Disable Voltage command
0x000	0x80 0x05	NMT: Enter PRE-OPERATIONAL

Table 26: Example of Profile Velocity Mode

7.9 Overview of CANopen identifiers

The following table offers an overview of the identifiers used in the AG03.

Default identifier (hexadecimal)	Default identifier (decimal)	Description	Own setting
0	0	Network management (NMT)	
80	128	SYNC – Message	
80 + Node-ID	128 + Node-ID	Emergency Message	
180 + Node-ID	384 + Node-ID	TPDO1	
200 + Node-ID	512 + Node-ID	RPDO1	
380 + Node-ID	896 + Node-ID	TPDO3	
400 + Node-ID	1024 + Node-ID	RPDO3	
480 + Node-ID	1152 + Node-ID	TPDO4	
500 + Node-ID	1280 + Node-ID	RPDO4	
580 + Node-ID	1408 + Node-ID	SDO (tx)	
600 + Node-ID	1536 + Node-ID	SDO (rx)	
700 + Node-ID	1792 + Node-ID	Heartbeat Message	
700 + Node-ID	1792 + Node-ID	Node-Guard Message	

Table 27: Overview of identifiers

7.10 Setting the CAN baud rate

The CAN baud rate is entered via Object 2100h (CAN baud rate).
The baud rate is factory-set to 500kbaud.

7.11 EDS file

The EDS file SIKOAG03.EDS (electronic data sheet) is available for the AG03.
This file enables easy integration and configuration of the AG03 in a CANopen network using commercial CANopen configurations.

7.12 Directory of objects

Every CANopen device keeps a directory of objects where all parameters of the device are deposited in the form of object entries. The object entries can be accessed via SDO communication services (see chapter 7.2.7). Thus, a parameter can be read (SDO upload) and written (SDO download) if permitted by the object entry access rights or the state of the device, respectively.

The following index ranges are used:

1000 _h - 1FFF _h	objects of the communication profile CIA DS-301 V4.0.
2000 _h - 5FFF _h	manufacturer-specific object entries.
6000 _h - 9FFF _h	objects of the device profile CIA DSP-402 V2.0.

7.12.1 Overview of objects

The following table offers an overview of the objects of the AG03.

Index	Name	Description
1000 _h	Device type	The object indicates the device profile number of the AG03.
1001 _h	Error register	The object shows error states of the AG03.
1002 _h	Manufacturer Status Register	Contains the system status word of the AG03 (<i>see chapter 2.1</i>)
1003 _h	Pre-Defined Error Field	The object stores up to 10 error messages.
1005 _h	COB-ID Sync Message	Setting of the COB ID of the SYNC object.
1008 _h	Manufacturer Device Name	Indicates the device name.
100A _h	Manufacturer Software Version	Indicates the software version of the controller firmware.
100C _h	Guard Time	Setting of the 'Guard Time' for the Node Guarding protocol (<i>see chapter 7.2.11</i>).
100D _h	Life Time Factor	Setting of the time interval 'Life Time' (<i>see chapter 7.2.11</i>).
1011 _h	Restore Default Parameters	Restoration of factory-set states of the changeable parameters and calibration of the AG03 (<i>see chapter 3: Calibration</i>).
1014 _h	COB-ID Emergency Message	Setting of the COB ID of the Emergency object.
1017 _h	Producer Heartbeat Time	Setting of the cycle time for the heartbeat protocol (<i>see chapter 7.2.10</i>).
1018 _h	Identity Objekt	Contains the Vendor ID of the device manufacturer.
1200 _h	Server SDO Parameter	Contains the COB IDs of the default server SDO.
1400 _h	1 st Receive PDO Parameter	Setting of the communication parameters of the RPDO1.
1402 _h	3 rd Receive PDO Parameter	Setting of the communication parameters of the RPDO3.
1403 _h	4 th Receive PDO Parameter	Setting of the communication parameters of the RPDO4.
1600 _h	1 st Receive PDO Mapping Parameter	Contains the objects mapped on the RPDO1 (<i>see chapter 7.2.6.1</i>).
1601 _h	2 nd Receive PDO Mapping Parameter	Compatibility entry
1602 _h	3 rd Receive PDO Mapping Parameter	Contains the objects mapped on the RPDO3 (<i>see chapter 7.2.6.2</i>).
1603 _h	4 th Receive PDO Mapping Parameter	Contains the objects mapped on the RPDO4 (<i>see chapter 7.2.6.3</i>).
1800 _h	1 st Transmit PDO parameter	Setting of the communication parameters of the TPDO1.
1801 _h	2 nd Transmit PDO Parameter	Compatibility entry
1802 _h	3 rd Transmit PDO Parameter	Setting of the communication parameters of the TPDO3.
1803 _h	4 th Transmit PDO Parameter	Setting of the communication parameters of the TPDO4.
1A00 _h	1 st Transmit PDO Mapping Parameter	Contains the objects mapped on the TPDO1 (<i>see chapter 7.2.5.1</i>).
1A01 _h	2 nd Transmit PDO Mapping Parameter	Compatibility entry
1A02 _h	3 rd Transmit PDO Mapping Parameter	Contains the objects mapped on the TPDO3 (<i>see chapter 7.2.5.2</i>).

Index	Name	Description
1A03 _h	4 th Transmit PDO Mapping Parameter	Contains the objects mapped on the TPDO4 (see chapter 7.2.5.3).
2100 _h	Can-Baud rate	Setting of the CAN baud rate of the AG03.
2101 _h	Node-ID	Setting of the node address of the AG03.
2102 _h	Transfer reduction	Contains the gear reduction of the AG03.
2410 _h	Motor Parameter Set	Setting of the control parameters of the drive controller (see chapter 6: Parameter description).
2412 _h	Spindle Pitch Set	Setting of the spindle pitch (see chapter 6: Parameter 13).
2413 _h	Pos Type Set	Setting of the positioning type (see chapter 6: Parameter 19).
2415 _h	Delta Jog Set	Setting of the travel distance in inching operation 1 (see chapter 6: Parameter 17).
2416 _h	Stop Mode Inching Mode 2	Setting of the stop behaviour in inching operation 2.
2417 _h	Inpos Mode	Setting of the behaviour upon reaching the positioning window.
2418 _h	Loop Length	Setting the loop length (see chapter 6: Parameter 27).
2420 _h	Generic Status Register	Represents the status of the enable entry and of torque deactivation.
2421 _h	Torque Deactivation	Setting of torque deactivation.
2422 _h	Torque Deactivation State	State of torque deactivation.
2500 _h	Production Date	Contains the drive's production date.
6040 _h	Controlword	Contains the control word of the state machine for drives
6041 _h	Statusword	Contains the status word of the state machine for drives.
6060 _h	Modes of Operation	Setting of the operation mode: Profile Position Mode / Profile Velocity Mode (see chapter 6: Parameter 20).
6064 _h	Position Actual Value	Contains the absolute actual position in the operation mode Profile Position Mode (positioning mode).
6067 _h	Position Window	Setting of the tolerance window (see chapter 6: Parameter 10).
606C _h	Velocity Actual Value	Contains the actual velocity in the operation mode Profile Velocity Mode (velocity mode).
607A _h	Target Position	Contains the target position in the operation mode Profile Position Mode (positioning mode).
607C _h	Calibration Value	Calibration of the AG03 (see chapter 6: Parameter 14 and chapter 3: Calibration).
607D _h	Software Position Limit	Setting of the limits (see chapter 6: Parameter 15/16).
607E _h	Polarity	Setting of the polarity (sense of rotation) of the AG03 (see chapter 6: Parameter 18).
6091 _h	Gear Ratio	Setting of gear ratio (see chapter 6: Parameter 11/12).
60FF _h	Target Velocity	Contains the target velocity in the operation mode Profile Velocity Mode (velocity mode).

Table 28: Overview of objects

7.12.2 Description of objects

Below, all objects of the positioning drive AG03 are described sorted by their indexes.



7.12.2.1 1000_h: Device Type

Object 1000_h indicates the device profile number.

Subindex	00 _h
Description	Information on the device profile
Access	read-only
PDO mapping	no
Data type	Unsigned32
Default	00000192 _h
EEPROM	no

Format description:

Bit 31 - 24	Manufacturer-specific (not used)
Bit 23 - 16	drive type (not used)
Bit 15 - 0	device profile number

7.12.2.2 1001_h: Error Register

Object 1001_h indicates the error state of the device.

Subindex	00 _h
Description	current error code
Access	read-only
PDO mapping	no
Data type	Unsigned8
Default	no
EEPROM	no

Format description:

Bit 7	Manufacturer-specific error
Bit 6	reserved (statically 0)
Bit 5	Drive shaft blocked
Bit 4	Error during data transfer
Bit 3	Temperature
Bit 2	Voltage
Bit 1	Current
Bit 0	General error (is set when error is present)

A detailed error evaluation can be attained via object 1003h (Predefined Error Field). Faults and errors are signalled at the time of their occurrence by an emergency message (see *chapter 7.2.9: Emergency Object*).

7.12.2.3 1002_h: Manufacturer Status Register

Object 1002_h indicates the system status word of the AG03 (see chapter 2.1: System Status Word).

Subindex	00 _h
Description	Manufacturer-specific status register
Access	read-only
PDO mapping	no
Data type	Unsigned16
Default	no
EEPROM	no

Format description:

Bit 31 -16	not used
Bit 15 - 0	see chapter 2.1: System Status Word

7.12.2.4 1003_h: Pre-defined Error Field

Object 1003_h stores the last 10 causes of faults.

The entry under sub-index 00_h contains the number of faults currently stored.

The latest fault message is stored under sub-index 01_h.

Writing a '0' on sub-index 00_h resets the fault buffer.

Subindex	00 _h
Description	number of fault messages
Access	read-write
PDO mapping	no
Data type	Unsigned8
Default	0
EEPROM	no
Value range	0 ... 10

Subindex	01 _h ... 0A _h
Description	faults that occurred
Access	read-only
PDO mapping	no
Data type	Unsigned16
Default	no
EEPROM	yes

Format description:

Bit 31 - 16	not used
Bit 15 - 8	error code high byte (see chapter 7.2.9.1)
Bit 7 - 0	error code low byte (see chapter 7.2.9.1)

7.12.2.5 1005_h: COB-ID Sync Message

The COB-ID of the SYNC object is set via object 1005_h.
The SYNC message is sent to all network participant (broadcast object).

Subindex	00 _h
Description	COB ID SYNC message
Access	read-write
PDO mapping	no
Data type	Unsigned32
Default	80 _h
EEPROM	yes

Format description:

Bit 31 - 30	not used
Bit 29	0 = 11-bit identifier (CAN 2.0A) 1 = 29-bit identifier (CAN 2.0B)
Bit 28 - 11	if bit 29=1, bit 28 ... 11 of the 29-bit identifier
Bit 10 - 0	bit 10 ...0 of the identifier



The COB-ID of the Sync message can be changed in the NMT status 'PREOPERATIONAL' only!

7.12.2.6 1008_h: Manufacturer Device Name

Object 1008_h indicates the device name.

Subindex	00 _h
Description	Device name in ASCII characters
Access	read-only
PDO mapping	no
Data type	Unsigned32 (max. 4 characters)
Default	no
EEPROM	no

Format description (example):

Bit 7 - 0	41 _h = ' A ' (ASCII character, ISO 8859)
Bit 15 - 8	47 _h = ' G ' (ASCII character, ISO 8859)
Bit 23 - 16	30 _h = ' 0 ' (ASCII character, ISO 8859)
Bit 31 - 24	33 _h = ' 3 ' (ASCII character, ISO 8859)

Device name = AG03

7.12.2.7 100A_h: Manufacturer Software Version

Object 100A_h indicates the software version of the controller firmware.

Subindex	00 _h
Description	Software version as ASCII characters
Access	read-only
PDO mapping	no
Data type	Unsigned32 (max. 4 characters)
Default	no
EEPROM	no

Format description (example):

Bit 7 - 0	31 _h = ' 1 ' (ASCII character, ISO 8859)
Bit 15 - 8	2E _h = ' . ' (ASCII character, ISO 8859)
Bit 23 - 16	30 _h = ' 0 ' (ASCII character, ISO 8859)
Bit 31 - 24	30 _h = ' 0 ' (ASCII character, ISO 8859)

Software version = V.1.00

7.12.2.8 100C_h: Guard Time

The cycle time 'Guard Time' for node guarding is set via object 100C_h.
The cycle time 'Guard Time' is given in milliseconds (see chapter 7.2.11: Node Guarding).

Subindex	00 _h
Description	Guard Time
Access	read-write
PDO mapping	no
Unit	milliseconds
Data type	Unsigned16
Default	no
EEPROM	yes

Data description:

Value '0' means that node guarding is deactivated.

7.12.2.9 100D_h: Life Time Factor

The time interval 'Life Time' for life guarding is set via object 100D_h (see chapter 7.2.11: Node Guarding).

Subindex	00 _h
Description	Life Time Factor
Access	read-write
PDO mapping	no
Data type	Unsigned8
Default	0
EEPROM	yes

Data description:

Value '0' means that Life Guarding is deactivated.

7.12.2.10 1011_h: Restore Default Parameters

The default values of the changeable parameters can be retrieved via object 1011_h. Parameter ranges are specified by selecting the respective subindex.

Sub-index 01_h: set all parameters to default values

Sub-index 02_h: set only standard parameters to default values.

Sub-index 03_h: set only control parameters to default values.

Sub-index 04_h: calibrate the AG03

Subindex	00 _h
Description	Number of subindexes
Access	read-only
PDO mapping	no
Data type	Unsigned8
Default	4
EEPROM	no

Subindex	01 _h
Description	set all parameters to default values
Access	write-only
PDO mapping	no
Data type	Unsigned32
Default	no
EEPROM	no

Subindex	02 _h
Description	set standard parameters to default values
Access	write-only
PDO mapping	no
Data type	Unsigned32
Default	no
EEPROM	no

Subindex	03 _h
Description	set controller parameters to default values
Access	write-only
PDO mapping	no
Data type	Unsigned32
Default	no
EEPROM	no

Subindex	04 _h
Description	calibrate the AG03
Access	write-only
PDO mapping	no
Data type	Unsigned32
Default	no
EEPROM	no

Format description sub-index 01_h – 04_h:

Bit 31 - 24	64 _h = ' d ' (ASCII character, ISO 8859)
Bit 23 - 16	61 _h = ' a ' (ASCII character, ISO 8859)
Bit 15 - 8	6F _h = ' o ' (ASCII character, ISO 8859)
Bit 7 - 0	6C _h = ' l ' (ASCII character, ISO 8859)

By writing the signature 'load' to a sub-index 0...3, the factory settings (see *chapter 6: Parameter description P Default column*) of the respective parameters are retrieved. By writing the signature 'load' to sub-index 04, the AG03 is calibrated (see *chapter 3: Calibration*).



Parameter Bus address or CAN baud rate are not changed by retrieval of the factory settings!

7.12.2.11 1014_h: COB-ID Emergency Message

The COB-ID of the Emergency object is set via object 1014_h (see *chapter 7.2.9: Emergency Object*).

Subindex	00 _h
Description	COB ID of the Emergency Message
Access	read-write
PDO mapping	no
Data type	Unsigned32
Default	80 _h + Node-ID
EEPROM	yes

Format description:

Bit 31	0 = EMCY existed / is valid 1 = EMCY does not exist / is not valid
Bit 30	reserved (always 0)
Bit 29	0 = 11-bit identifier (CAN 2.0A) 1 = 29-bit identifier (CAN 2.0B)
Bit 28 -11	if bit 29=1, bit 28 ... 11 of the 29-bit identifier
Bit 10 - 0	bit 10 ...0 of the identifier



The COB ID of the Emergency message can be changed in the NMT status 'PREOPERATIONAL' only!

7.12.2.12 1017_h: Producer Heartbeat Time

The cycle time 'Heartbeat Time' for the heartbeat protocol is set via object 1017_h. The 'Heartbeat Time' is given in milliseconds (see *chapter 7.2.10: Heartbeat protocol*).

Subindex	00 _h
Description	Producer Heartbeat Time
Access	read-write
PDO mapping	no
Unit	milliseconds
Data type	Unsigned16
Default	0
EEPROM	yes

Data description:

Value '0' means that the heartbeat protocol is deactivated.

7.12.2.13 1018_h: Identity Objekt

The Vendor ID of the manufacturer is indicated via object 1018_h.

Subindex	00 _h
Description	Number of subindexes
Access	read-only
PDO mapping	no
Data type	Unsigned8
Default	1
EEPROM	no

Subindex	01 _h
Description	Vendor ID
Access	read-only
PDO mapping	no
Data type	Unsigned32
Default	195 _h (SIKO GmbH)
EEPROM	no

Subindex	02 _h
Description	Product Code (no function: Compatibility entry)
Access	read-only
PDO mapping	no
Data type	Unsigned32
Default	0
EEPROM	no

Subindex	03 _h
Description	Revision Number (no function: Compatibility entry)
Access	read-only
PDO mapping	no
Datentyp	Unsigned32
Data type	0
EEPROM	no



Subindex	04 _h
Description	Serial Number
Access	read-only
PDO mapping	no
Data type	Unsigned32
Default	no
EEPROM	no

Vendor ID:

The Vendor ID is assigned by the CAN user organization CiA e.V. (CAN in Automation). Vendor ID '195_h' has been assigned to the company SIKO GmbH.

7.12.2.14 1200_h: Server SDO Parameter

The COB IDs for the Default Server SDO are indicated via object 1200_h (see also chapter 7.2.7: Service Data Objects).

Subindex	00 _h
Description	Number of subindexes
Access	read-only
PDO mapping	no
Data type	Unsigned8
Default	2
EEPROM	no

Subindex	01 _h
Description	COB ID Master ⇒ AG03 (rx)
Access	read-only
PDO mapping	no
Data type	Unsigned32
Default	600 _h + Node-ID
EEPROM	no

Subindex	02 _h
Description	COB-ID AG03 ⇒ Master (tx)
Access	read-only
PDO mapping	no
Data type	Unsigned32
Default	580 _h + Node-ID
EEPROM	no

Format description:

Bit 31	0 = SDO valid 1 = SDO not valid
Bit 30	reserved (statically 0)
Bit 29	0 = 11-bit identifier (CAN 2.0A) 1 = 29-bit identifier (CAN 2.0B)
Bit 28 - 11	if bit 29=1, bit 28 ... 11 of the 29-bit identifier
Bit 10 - 7	4 bit function code of the identifier
Bit 6 - 0	7 bit Node ID of the identifier

Data description:

The default DSO cannot be changed (according to the CiA DS-301 Predefined Connection Set).

7.12.2.15 1400_h: 1st Receive PDO Parameter

The communication parameters of the first Receive PDO (RPDO1) are set via object 1400_h.

Subindex	00 _h
Description	largest sub-index supported
Access	read-only
PDO mapping	no
Data type	Unsigned8
Default	2
EEPROM	no

Subindex	01 _h
Description	COB-ID
Access	read-write
PDO mapping	no
Data type	Unsigned32
Default	200 _h + Node-ID
EEPROM	no

Subindex	02 _h
Description	Transfer type (see chapter 7.2.6.4: Transfer types of Receive PDOs)
Access	read-write
PDO mapping	no
Data type	Unsigned8
Default	255
EEPROM	no

Subindex	03 _h
Description	Inhibit Time (no function: Compatibility entry)
Access	read
PDO mapping	no
Data type	Unsigned16
Default	0
EEPROM	no

Subindex	05 _h
Description	Event Timer (no function: Compatibility entry)
Access	read
PDO mapping	no
Data type	Unsigned16
Default	0
EEPROM	no

Format description sub-index 01_h:

Bit 31	not used
Bit 30	not used
Bit 29	0 = 11-bit identifier (CAN 2.0A) 1 = 29-bit identifier (CAN 2.0B)
Bit 28 - 11	if bit 29=1, bit 28 ... 11 of the 29-bit identifier
Bit 10 - 7	4 bit function code of the identifier
Bit 6 - 0	7 bit Node ID of the identifier



Data description sub-index 02_h:

0	synchronous: RPDO1 is processed only after a SYNC message has been received
1 ... 240	synchronous: identical with value 0
241 ... 251	reserved
252	reserved
253	reserved
254	identical with value 255
255	asynchronous: RPDO1 is immediately processed

PDO mapping:

see object 1600_h (1st receive PDO mapping parameter).

Processing of PDOs:

Receive PDOs are processed in the NMT status 'OPERATIONAL' only. It is not recommended to change the transfer type of the RPDO1 since otherwise the functioning of the state machine would no longer be ensured.

Changing PDO parameters:

PDO parameters can be changed in the NMT status 'PRE-OPERATIONAL' only.

7.12.2.16 1401_h: 2nd Receive PDO Parameter

Object 1401h was implemented for compatibility reasons only and has no function.

Subindex	00 _h
Description	largest sub-index supported
Access	read-only
PDO mapping	no
Data type	Unsigned8
Default	5
EEPROM	no

Subindex	01 _h
Description	COB-ID (no function: Compatibility entry)
Access	read-only
PDO mapping	no
Data type	Unsigned32
Default	301 _h
EEPROM	no

Subindex	02 _h
Description	Transmission type (no function: Compatibility entry)
Access	read-only
PDO mapping	no
Data type	Unsigned8
Default	255
EEPROM	no

Subindex	03 _h
Description	Inhibit Time (no function: Compatibility entry)
Access	read-only
PDO mapping	no
Data type	Unsigned16
Default	0
EEPROM	no

Subindex	05 _h
Description	Event Timer (no function: Compatibility entry)
Access	read-only
PDO mapping	no
Data type	Unsigned16
Default	0
EEPROM	no

7.12.2.17 1402_h: 3rd Receive PDO Parameter

The communication parameters of the third Receive PDO (RPDO3) are set via object 1402_h.

Subindex	00 _h
Description	largest sub-index supported
Access	read-only
PDO mapping	no
Data type	Unsigned8
Default	5
EEPROM	no

Subindex	01 _h
Description	COB-ID
Access	read-write
PDO mapping	no
Data type	Unsigned32
Default	400 _h + Node-ID
EEPROM	no

Subindex	02 _h
Description	Transfer type (see chapter 7.2.6.4: Transfer types of Receive PDOs)
Access	read-write
PDO mapping	no
Data type	Unsigned8
Default	255
EEPROM	no

Subindex	03 _h
Description	Inhibit Time (no function: Compatibility entry)
Access	read
PDO mapping	no
Data type	Unsigned16
Default	0
EEPROM	no



Subindex	05 _h
Description	Event Timer (no function: Compatibility entry)
Access	read
PDO mapping	no
Data type	Unsigned16
Default	0
EEPROM	no

Format description sub-index 01_h:

Bit 31	not used
Bit 30	not used
Bit 29	0 = 11-bit identifier (CAN 2.0A) 1 = 29-bit identifier (CAN 2.0B)
Bit 28 - 11	if bit 29=1, bit 28 ... 11 of the 29-bit identifier
Bit 10 - 7	4 bit function code of the identifier
Bit 6 - 0	7 bit Node ID of the identifier

Data description sub-index 02_h:

0	synchronous: RPDO1 is processed only after a SYNC message has been received
1 ... 240	synchronous: identical with value 0
241 ... 251	reserved
252	reserved
253	reserved
254	identical with value 255
255	asynchronous: RPDO1 is immediately processed

PDO mapping:

see object 1602_h (3rd receive PDO mapping parameter).

Processing of PDOs:

Receive PDOs are processed in the NMT status 'OPERATIONAL' only.

Changing PDO parameters:

PDO parameters can be changed in the NMT status 'PRE-OPERATIONAL' only.

7.12.2.18 1403_h: 4th Receive PDO Parameter

The communication parameters of the fourth Receive PDO (RPDO4) are set via object 1403_h.

Subindex	00 _h
Description	largest sub-index supported
Access	read-only
PDO mapping	no
Data type	Unsigned8
Default	5
EEPROM	no

Subindex	01 _h
Description	COB ID
Access	read-write
PDO mapping	no
Data type	Unsigned32
Default	500 _h + Node-ID
EEPROM	no

Subindex	02 _h
Description	Transfer type (see chapter 7.2.6.4: Transfer types of Receive PDOs)
Access	read-write
PDO mapping	no
Data type	Unsigned8
Default	255
EEPROM	no

Subindex	03 _h
Description	Inhibit Time (no function: Compatibility entry)
Access	read
PDO mapping	no
Data type	Unsigned16
Default	0
EEPROM	no

Subindex	05 _h
Description	Event Timer (no function: Compatibility entry)
Access	read
PDO mapping	no
Data type	Unsigned16
Default	0
EEPROM	no

Format description sub-index 01_h:

Bit 31	not used
Bit 30	not used
Bit 29	0 = 11-bit identifier (CAN 2.0A) 1 = 29-bit identifier (CAN 2.0B)
Bit 28 - 11	if bit 29=1, bit 28 ... 11 of the 29-bit identifier
Bit 10 - 7	4 bit function code of the identifier
Bit 6 - 0	7 bit Node ID of the identifier

Data description sub-index 02_h:

0	synchronous: RPDO1 is processed only after a SYNC message has been received
1 ... 240	synchronous: identical with value 0
241 ... 251	reserved
252	reserved
253	reserved
254	identical with value 255
255	asynchronous: RPDO1 is immediately processed

PDO mapping:

see object 1603_h (4th receive PDO mapping parameter).

Processing of PDOs:

Receive PDOs are processed in the NMT status 'OPERATIONAL' only.

Changing PDO parameters:

PDO parameters can be changed in the NMT status 'PRE-OPERATIONAL' only.

7.12.2.19 1600_h: 1st Receive PDO Mapping Parameter

Object 1600_h determines the objects that are mapped on the first Receive PDO (RPDO1).

Subindex	00 _h
Description	Number of mapped application objects in RPDO 1
Access	read-only
PDO mapping	no
Data type	Unsigned8
Default	1
EEPROM	no

Subindex	01 _h
Description	first object mapped
Access	read-only
PDO mapping	no
Data type	Unsigned32
Default	60400010 _h
EEPROM	no

Format description sub-index 01_h:

Bit 31 - 16	Index 16 bits
Bit 15 - 8	Sub-index 8 bits
Bit 7 - 0	8 bits object length

Data description

The object cannot be changed (static mapping).

Mapped objects:

- object 6040_h (control word) in bytes 0 and 1.

7.12.2.20 1601_h: 2nd Receive PDO Mapping Parameter

Object 1601_h was implemented for compatibility reasons only and has no function.

Subindex	00 _h
Description	Number of mapped application objects in RPDO 2
Access	read-only
PDO mapping	no
Data type	Unsigned8
Default	0
EEPROM	no

7.12.2.21 1602_h: 3rd Receive PDO Mapping Parameter

Object 1602_h determines the objects that are mapped on the third Receive PDO (RPDO3).

Subindex	00 _h
Description	Number of mapped application objects in RPDO 3
Access	read-only
PDO mapping	no
Data type	Unsigned8
Default	2
EEPROM	no

Subindex	01 _h
Description	first object mapped
Access	read-only
PDO mapping	no
Data type	Unsigned32
Default	60400010 _h
EEPROM	no

Subindex	02 _h
Description	second object mapped
Access	read-only
PDO mapping	no
Data type	Unsigned32
Default	607A0020 _h
EEPROM	no

Format description sub-index 01_h – 02_h:

Bit 31 -16	index 16 Bit
Bit 15 -8	sub-index 8 bits
Bit 7 0	8 bits object length

Data Description:

The object cannot be changed (static mapping).

Mapped objects:

- object 6040_h (control word) in bytes 0 and 1.
- object 607A_h (target position) in bytes 2 to 5.

7.12.2.22 1603_h: 4th Receive PDO Mapping Parameter

Object 1603_h determines the objects that are mapped on the fourth Receive PDO (RPDO4).

Subindex	00 _h
Description	Number of mapped application objects in RPDO 4
Access	read-only
PDO mapping	no
Data type	Unsigned8
Default	2
EEPROM	no

Subindex	01 _h
Description	first object mapped
Access	read-only
PDO mapping	no
Data type	Unsigned32
Default	60400010 _h
EEPROM	no

Subindex	02 _h
Description	second object mapped
Access	read-only
PDO mapping	no
Data type	Unsigned32
Default	60FF0020 _h
EEPROM	no

Format description sub-index 01_h – 02_h:

Bit 31 - 16	index 16 bits
Bit 15 - 8	sub-index 8 bits
Bit 7 - 0	8 bits object length

Data description:

The object cannot be changed (static mapping).

Mapped objects:

- object 6040_h (control word) in bytes 0 and 1.
- object 60FF_h (target velocity) in bytes 2 to 5.

7.12.2.23 1800_h: 1st Transmit PDO Parameter

The communication parameters of the first Transmit PDO (TPDO1) are set via object 1800_h.

Subindex	00 _h
Description	largest sub-index supported
Access	read-only
PDO mapping	no
Data type	Unsigned8
Default	5
EEPROM	no

Subindex	01 _h
Description	COB-ID
Access	read-write
PDO mapping	no
Data type	Unsigned32
Default	180 _h + Node-ID
EEPROM	no

Subindex	02 _h
Description	Transfer type (see chapter 7.2.5.4: Transfer types of Transmit PDOs)
Access	read-write
PDO mapping	no
Data type	Unsigned8
Default	255
EEPROM	no

Subindex	03 _h
Description	Inhibit Time (no function: Compatibility entry)
Access	read
PDO mapping	no
Data type	Unsigned16
Default	0
EEPROM	no

Subindex	05 _h
Description	Event Timer
Access	read-write
PDO mapping	no
Unit	milliseconds
Data type	Unsigned16
Default	100
EEPROM	yes
Value range	10 ... 65535



Format description sub-index 01_h:

Bit 31	0 = PDO existed / is valid 1 = PDO does not exist / is not valid
Bit 30	0 = request via RTR frame enabled 1 = request via RTR frame disabled
Bit 29	0 = 11-bit identifier (CAN 2.0A) 1 = 29-bit identifier (CAN 2.0B)
Bit 28 - 11	if bit 29=1, bit 28 ... 11 of the 29-bit identifier
Bit 10 - 7	4 bit function code of the identifier
Bit 6 - 0	7 bit Node-ID of the identifier

Data description sub-index 02_h:

0	synchronous: acyclic, PDO is sent after each SYNC message.
1 ... 240	synchronous: cyclic, PDO is sent after 1...240 SYNC messages received.
241 ... 251	reserved
252	reserved
253	asynchronous: on request (RTR frame). PDO is sent immediately after receipt of the RTR frame. Attention! Must have been enabled via bit 30 of sub-index 1.
254	identical with value 255
255	asynchronous: time-triggered

PDO mapping:

see object 1A00_h (*1st transmit PDO mapping parameter*).

Event Timer:

The 'Event Timer' parameter serves for setting a cycle time (in milliseconds) for time-triggered transfer of the Transmit PDO1.

Processing of PDOs:

Transmit PDOs are transferred in the NMT status 'OPERATIONAL' only.
It is not recommended to change the transfer type of the TPDO1 since otherwise the functioning of the state machine would no longer be ensured.

Changing PDO parameters:

PDO parameters can be changed in the NMT status 'PRE-OPERATIONAL' only.

7.12.2.24 1801_h: 2nd Transmit PDO Parameter

Object 1801h was implemented for compatibility reasons only and has no function.

Subindex	00 _h
Description	largest sub-index supported
Access	read-only
PDO mapping	no
Data type	Unsigned8
Default	5
EEPROM	no

Subindex	01 _h
Description	COB-ID
Access	read-only
PDO mapping	no
Data type	Unsigned32
Default	281 _h
EEPROM	no

Subindex	02 _h
Description	Transmission type (no function: Compatibility entry)
Access	read-only
PDO mapping	no
Data type	Unsigned8
Default	255
EEPROM	no

Subindex	03 _h
Description	Inhibit Time (no function: Compatibility entry)
Access	read-only
PDO mapping	no
v	Unsigned16
Default	0
EEPROM	no

Subindex	05 _h
Description	Event Timer (no function: Compatibility entry)
Access	read-only
PDO mapping	no
Unit	milliseconds
Data type	Unsigned16
Default	100
EEPROM	no

7.12.2.25 1802_h: 3rd Transmit PDO Parameter

The communication parameters of the third Transmit PDO (TPDO3) are set via object 1802_h (TPDO3) eingestellt.

Subindex	00 _h
Description	largest sub-index supported
Access	read-only
PDO mapping	no
Data type	Unsigned8
Default	5
EEPROM	no

Subindex	01 _h
Description	COB-ID
Access	read-write
PDO mapping	no
Data type	Unsigned32
Default	380 _h + Node-ID
EEPROM	no

Subindex	02 _h
Description	Transfer type (see chapter 7.2.5.4: Transfer types of Transmit PDOs)
Access	read-write
PDO mapping	no
Data type	Unsigned8
Default	253
EEPROM	no

Subindex	03 _h
Description	Inhibit Time (no function: Compatibility entry)
Access	read-only
PDO mapping	no
Data type	Unsigned16
Default	0
EEPROM	no

Subindex	05 _h
Description	Event Timer
Access	read-write
PDO mapping	no
Unit	milliseconds
Data type	Unsigned16:
Default	100
EEPROM	no
Value range	10 ... 65535



Format description sub-index 01_h:

Bit 31	0 = PDO existed / is valid 1 = PDO does not exist / is not valid
Bit 30	0 = request via RTR frame enabled 1 = request via RTR frame disabled
Bit 29	0 = 11-bit identifier (CAN 2.0A) 1 = 29-bit identifier (CAN 2.0B)
Bit 28 - 11	if bit 29=1, bit 28 ... 11 of the 29-bit identifier
Bit 10 - 7	4 bit function code of the identifier
Bit 6 - 0	7 bit Node-ID of the identifier

Data description sub-index 02_h:

0	synchronous: acyclic, PDO is sent after each SYNC message.
1 ... 240	synchronous: cyclic, PDO is sent after 1 ... 240 SYNC messages received.
241 ... 251	reserved
252	reserved
253	asynchronous: on request (RTR frame). PDO is sent immediately after receipt of the RTR frame. Attention! Must have been enabled via bit 30 of sub-index 1.
254	asynchronous: event-triggered (with every change of the position value)
255	asynchronous: time-triggered

PDO mapping:

see object 1A02_h (3rd transmit PDO mapping parameter).

Event Timer:

The 'Event Timer' parameter serves for setting a cycle time (in milliseconds) for time-triggered transfer of the Transmit PDO3.

Processing of PDOs:

Transmit PDOs are transferred in the NMT status 'OPERATIONAL' only.

Changing PDO parameters:

PDO parameters can be changed in the NMT status 'PRE-OPERATIONAL' only.

7.12.2.26 1803_h: 4th Transmit PDO Parameter

The communication parameters of the fourth Transmit PDO (TPDO4) are set via object 1803_h.

Subindex	00 _h
Description	largest sub-index supported
Access	read-only
PDO mapping	no
Data type	Unsigned8
Default	5
EEPROM	no



Subindex	01 _h
Description	COB-ID
Access	read-write
PDO mapping	no
Data type	Unsigned32
Default	480 _h + Node-ID
EEPROM	no

Subindex	02 _h
Description	Transfer type (see chapter 7.2.5.4: Transfer types of Transmit PDOs)
Access	read-write
PDO mapping	no
Data type	Unsigned8
Default	253
EEPROM	no

Subindex	03 _h
Description	Inhibit Time (no function: Compatibility entry)
Access	read-only
PDO mapping	no
Data type	Unsigned16
Default	0
EEPROM	no

Subindex	05 _h
Description	Event Timer
Access	read-write
PDO mapping	no
Unit	milliseconds
Data type	Unsigned16:
Default	100
EEPROM	no
Value range	10 ... 65535

Format description sub-index 01_h:

Bit 31	0 = PDO existed / is valid 1 = PDO does not exist / is not valid
Bit 30	0 = request via RTR frame enabled 1 = request via RTR frame disabled
Bit 29	0 = 11-bit identifier (CAN 2.0A) 1 = 29-bit identifier (CAN 2.0B)
Bit 28 - 11	if bit 29=1, bit 28 ... 11 of the 29-bit identifier
Bit 10 - 7	4 bit function code of the identifier
Bit 6 - 0	7 bit Node-ID of the identifier

Data description sub-index 02_h:

0	synchronous: acyclic, PDO is sent after each SYNC message.
1 ... 240	synchronous: cyclic, PDO is sent after 1 ... 240 SYNC messages received.
241 ... 251	reserved



252	reserved
253	asynchronous: on request (RTR frame). PDO is sent immediately after receipt of the RTR frame. Attention! Must have been enabled via bit 30 of sub-index 1.
254	asynchronous: Event-triggered (with every change of actual velocity).
255	asynchronous: time-triggered

PDO mapping:

see object 1A03_h (4th transmit PDO mapping parameter).

Event Timer:

The 'Event Timer' parameter serves for setting a cycle time (in milliseconds) for time-triggered transfer of the Transmit PDO4.

Processing of PDOs:

Transmit PDOs are transferred in the NMT status 'OPERATIONAL' only.

Changing PDO parameters:

PDO parameters can be changed in the NMT status 'PRE-OPERATIONAL' only.

7.12.2.27 1A00_h: 1st Transmit PDO Mapping Parameter

Object 1A00_h determines the objects that are mapped on the first Transmit PDO (TPDO1).

Subindex	00 _h
Description	Number of mapped application objects in TPDO 1
Access	read-only
PDO mapping	no
Data type	Unsigned8
Default	1
EEPROM	no

Subindex	01 _h
Description	first object mapped
Access	read-only
PDO mapping	no
Data type	Unsigned32
Default	60410010 _h
EEPROM	no

Format description sub-index 01_h:

Bit 31 - 16	index 16 bits
Bit 15 - 8	sub-index 8 bits
Bit 7 - 0	8 bits object length

Data description:

The object cannot be changed (static mapping).

Mapped objects:

- object 6041_h (status word) in bytes 0 and 1.

7.12.2.28 1A01_h: 2nd Transmit PDO Mapping Parameter

Object 1A01_h was implemented for compatibility reasons only and has no function.

Subindex	00 _h
Description	Number of mapped application objects in TPDO 2
Access	read-only
PDO mapping	no
Data type	Unsigned8
Default	0
EEPROM	no

7.12.2.29 1A02_h: 3rd Transmit PDO Mapping Parameter

Object 1A02_h determines the objects that are mapped on the third Transmit PDO (TPDO3).

Subindex	00 _h
Description	Number of mapped application objects in TPDO 3
Access	read-only
PDO mapping	no
Data type	Unsigned8
Default	2
EEPROM	no

Subindex	01 _h
Description	first object mapped
Access	read-only
PDO mapping	no
Data type	Unsigned32
Default	60410010 _h
EEPROM	no

Subindex	02 _h
Description	second object mapped
Access	read-only
PDO mapping	no
Data type	Unsigned32
Default	60640020 _h
EEPROM	no

Format description sub-index 01_h – 02_h:

Bit 31 - 16	index 16 bits
Bit 15 - 8	sub-index 8 bits
Bit 7 - 0	8 bits object length



Data description:

The object cannot be changed (static mapping).

Mapped objects:

- object 6041_h (status word) in bytes 0 and 1.
- object 6064_h (position actual value) in bytes 2 to 5.

7.12.2.30 1A03_h: 4th Transmit PDO Mapping Parameter

Object 1A03_h determines the objects that are mapped on the fourth Transmit PDO (TPDO4).

Subindex	00 _h
Description	Number of mapped application objects in TPDO 4
Access	read-only
PDO mapping	no
Data type	Unsigned8
Default	2
EEPROM	no

Subindex	01 _h
Description	first object mapped
Access	read-only
PDO mapping	no
Data type	Unsigned32
Default	60410010 _h
EEPROM	no

Subindex	02 _h
Description	second object mapped
Access	read-only
PDO mapping	no
Data type	Unsigned32
Default	606C0020 _h
EEPROM	no

Format description sub-index 01_h – 02_h:

Bit 31 - 16	index 16 bits
Bit 15 - 8	sub-index 8 bits
Bit 7 - 0	8 bits object length

Data description:

The object cannot be changed (static mapping).

Mapped objects:

- object 6041_h (status word) in bytes 0 and 1.
- object 606C_h (velocity actual value) in bytes 2 to 5.

7.12.2.31 2100_h: CAN baud rate

The CAN baud rate is set via object 2100_h.

Subindex	00 _h
Description	CAN baud rate (see chapter 6: Parameter description ⇒ parameter no. 23)
Access	read-write
PDO mapping	no
Data type	Unsigned8
Default	10
EEPROM	yes
Value range	0 ... 11

Data description:

Value = 0:	15,625	kBaud
Value = 1:	20	kBaud
Value = 2:	25	kBaud
Value = 3:	40	kBaud
Value = 4:	50	kBaud
Value = 5:	62,5	kBaud
Value = 6:	100	kBaud
Value = 7:	125	kBaud
Value = 8:	200	kBaud
Value = 9:	250	kBaud
Value = 10:	500	kBaud
Value = 11:	1000	kBaud



Baud rate change is only possible in PRO-OPERATIONAL NMT-status!



**The baud rate is taken over only after the next initialization of the positioning drive!
The Master must be adjusted to the new baud rate as well!**

7.12.2.32 2101_h: Node-ID

The set node ID of the AG03 can be read via object 2101_h.

Subindex	00 _h
Description	Node-ID (see chapter 6: Parameter description ⇒ parameter no. 22)
Access	read
PDO mapping	no
Data type	Unsigned8
Default	1
EEPROM	yes
Value range	1 ... 127



7.12.2.33 2102_h: Gear reduction

The gear reduction of the AG03 can be read out via object 2102_h.

Subindex	00 _h
Description	Gear reduction
Access	read
PDO mapping	no
Data type	Unsigned8
Default	no
EEPROM	no
Value range	2 ... 3

Data description:

Value = 2: Gear reduction 24:1

Value = 3: Gear reduction 48:1

7.12.2.34 2410_h: Motor Parameter Set

Object 2410_h contains all adjustable control parameters of the drive controller.

Subindex	00 _h
Description	largest sub-index supported
Access	read-only
PDO mapping	no
Data type	Unsigned8
Default	9
EEPROM	no

Subindex	01 _h
Description	Controller parameter P (see chapter 6: Parameter description <i>P</i> parameter no. 1)
Access	read-write
PDO mapping	no
Data type	Unsigned16:
Default	100
EEPROM	yes
Value range	1 ... 500

Subindex	02 _h
Description	Controller parameter I (see chapter 6: Parameter description <i>P</i> parameter no. 2)
Access	read-write
PDO mapping	no
Data type	Unsigned16
Default	5
EEPROM	yes

Subindex	03 _h
Description	Controller parameter D (see chapter 6: Parameter description P parameter no. 3)
Access	read-write
PDO mapping	no
Data type	Unsigned16
Default	0
EEPROM	yes
Value range	0 ... 500

Subindex	04 _h
Description	a- Pos (acceleration positioning mode) (see chapter 6: Parameter description P parameter no. 4)
Access	read-write
PDO mapping	no
Data type	Unsigned8
Default	50
EEPROM	yes
Value range	1 ... 100

Subindex	05 _h
Description	v- Pos (velocity positioning mode) (see chapter 6: Parameter description P parameter no. 5)
Access	read-write
PDO mapping	no
Data type	Unsigned8
Default	30
EEPROM	yes
Value range	Gear 24:1 ⇒ 1...200 Gear 48:1 ⇒ 1...100

Subindex	06 _h
Description	a – Rot (acceleration velocity mode) (see chapter 6: Parameter description P parameter no. 6)
Access	read-write
PDO mapping	no
Data type	Unsigned8
Default	50
EEPROM	yes
Value range	1 ... 100

Subindex	08 _h
Description	a – Inch (acceleration inching operation) (see chapter 6: Parameter description P parameter no. 8)
Access	read-write
PDO mapping	no
Data type	Unsigned8
Default	50
EEPROM	yes
Value range	1 ... 100

Subindex	09 _h
Description	v – Inch (velocity inching operation) (see chapter 8: Parameter description <i>P</i> parameter no. 9)
Access	read-write
PDO mapping	no
Data type	Unsigned8
Default	30
EEPROM	yes
Value range	Gear 24:1 ⇒ 1...200 Gear 48:1 ⇒ 1...100

7.12.2.35 2412_h: Spindle Pitch

Spindle pitch is set via object 2412_h.

Subindex	00 _h
Description	Spindle pitch (see chapter 6: Parameter description <i>P</i> parameter no. 13)
Access	read-write
PDO mapping	no
Data type	Unsigned16
Default	0
EEPROM	yes
Value range	0 ... 1000

7.12.2.36 2413_h: Pos Type

The positioning type is set via object 2413_h.

Subindex	00 _h
Description	Positioning type (see chapter 6: Parameter description <i>P</i> parameter no. 19)
Access	read-write
PDO mapping	no
Data type	Unsigned8
Default	0
EEPROM	yes
Value range	0 ... 2

Data description:

Value = 0: direct
Value = 1: loop +
Value = 2: loop –

7.12.2.37 2415_h: Delta Jog

The travel distance in inching operation 1 is set via object 2415_h.

Subindex	00 _h
Description	Travel distance inching operation 1 (see chapter 6: Parameter description <i>P</i> parameter no. 17)
Access	read-write
PDO mapping	no
Data type	Integer32
Default	1600
EEPROM	yes
Value range	- 1000000 ... + 1000000

7.12.2.38 2416_h: Stop Mode Inching Mode 2

The stop behaviour in inching mode 2 is set via object 2416_h.

Subindex	00 _h
Description	stop mode inching 2 (see chapter 6: Parameter description <i>P</i> parameter no. 25)
Access	read-write
PDO mapping	no
Data type	Unsigned8
Default	0
EEPROM	yes
Value range	0-1

7.12.2.39 2417_h: Inpos Mode

The drive's behaviour when reaching the positioning window is defined by object 2417_h.

Subindex	00 _h
Description	Inpos Mode (see chapter 6: Parameter description <i>P</i> parameter no. 26)
Access	read-write
PDO mapping	no
Data type	Unsigned8
Default	0
EEPROM	yes
Value range	0-2

7.12.2.40 2418_h: Loop Length

Loop length is determined by Object 2418_h.

Subindex	00 _h
Description	Loop Length (see chapter 6: Parameter description <i>P</i> parameter no. 27)
Access	read-write
PDO mapping	no
Data type	Unsigned16
Default	800
EEPROM	yes
Value range	0-10000

7.12.2.41 2420_h: Generic Status Register

The state of enable entry and torque deactivation can be read via object 2420_h.

Subindex	00 _h
Description	State of torque deactivation and enable entry
Access	read
PDO mapping	no
Data type	Unsigned8
Default	no
EEPROM	no

Format description:

Bit 7	State of torque deactivation 0 = inactive 1 = active
Bit 4	State of enable entry 0 = inactive 1 = active
Bit 0 - 3 ; 5 - 6	not used

7.12.2.42 2421_h: Torque Deactivation

Torque deactivation is set via object 2421_h.

Subindex	00 _h
Description	Torque deactivation (see chapter 6: Parameter description P parameter no. 29)
Access	read-write
PDO mapping	no
Data type	Unsigned8
Default	125
EEPROM	yes
Value range	20-125

7.12.2.43 2422_h: Torque Deactivation State

The state of torque deactivation can be read via object 2422_h.

Subindex	00 _h
Description	State of torque deactivation
Access	read
PDO mapping	no
Data type	Unsigned8
Default	no
EEPROM	no

Format description:

Bit 1-7	not used
Bit 0	State of torque deactivation 0 = inactive 1 = active

7.12.2.44 2500_h: Production Date

Object 2500_h indicates the production date.

Subindex	00 _h
Description	date of production in readable hex notation
Access	read-only
PDO mapping	no
Data type	Unsigned32
Default	no
EEPROM	yes

Format description (example):

15 07 20 09_h = 15.07.2009 = DDMMJJJJ

7.12.2.45 6040_h: Control word

The object 6040_h is the control word of the state machine for drives according to the device profile CiA DSP-402.

Subindex	00 _h
Description	control word
Access	read-write
PDO mapping	yes
Data type	Unsigned16
Default	no
EEPROM	no

Format description:

see chapter: 7.5: Control word

PDO mapping:

The control word is mapped on the three Receive PDOs (see objects 1600_h – 1603_h).

7.12.2.46 6041_h: Status word

The object 6041_h is the status word of the state machine for drives according to the device profile CiA DSP-402.

Subindex	00 _h
Description	Status word
Access	read-only
PDO mapping	yes
Data type	Unsigned16
Default	no
EEPROM	no

Format description:

see chapter: 7.4: Status word

PDO mapping:

The status word is mapped on the three Transmit PDOs (see objects 1A00_h – 1A03_h).

7.12.2.47 6060_h: Modes of Operation

The operation mode of the AG03 is set via object 6060_h.

Subindex	00 _h
Description	Operating mode (see chapter 6: Parameter description <i>P</i> parameter no. 20)
Access	read-write
PDO mapping	no
Data type	Unsigned8
Default	1
EEPROM	yes
Value range	1 ... 2

Data description

Value = 1: Profile Position Mode (positioning mode)
 Value = 2: Profile Velocity Mode (velocity mode)

7.12.2.48 6064_h: Position Actual Value

Object 6064_h contains the actual position value in the Profile Position Mode (positioning mode).

Subindex	00 _h
Description	absolute position value in the positioning mode
Access	read-only
PDO mapping	yes
Data type	Integer32
Default	no
EEPROM	no

PDO mapping:

The absolute position value and the status word of the state machine are mapped on the Transmit PDO3, see object 1A02_h (3rd Transmit PDO mapping parameter).

7.12.2.49 6067_h: Position Window

A symmetric range of tolerable positions for standstill monitoring in the target point of positioning is set via object 6067_h.

Subindex	00 _h
Description	Pos- window (see chapter 6: Parameter description <i>P</i> parameter no. 10)
Access	read-write
PDO mapping	no
Data type	Unsigned16
Default	10
EEPROM	yes
Value range	0 ...1000

7.12.2.50 606C_h: Velocity Actual Value

Object 606C_h contains the actual velocity in the Profile Velocity Mode (velocity mode).

Subindex	00 _h
Description	Actual velocity in velocity mode
Access	read-only
PDO mapping	yes
Data type	Integer32
Default	no
EEPROM	no

PDO mapping:

The actual velocity and the status word of the state machine are mapped on the Transmit PDO4, see object 1A03_h (4th Transmit PDO mapping parameter).

7.12.2.51 607A_h: Target Position

The target position of a drive movement in the operation mode Profile Position Mode (position mode) is entered via object 607A_h.

Subindex	00 _h
Description	setpoint in the positioning mode
Access	read-write
PDO mapping	yes
Data type	Integer32
Default	no
EEPROM	no
Value range	± 9999999

PDO mapping:

The target position and the control word of the state machine are mapped on the Receive PDO3, see object 1602_h (3rd Receive PDO mapping parameter).

7.12.2.52 607C_h: Calibration Value

The calibration value is programmed and the programmed calibration value taken over as the absolute position value via object 607C_h.

Subindex	00 _h
Description	Calibration value (see chapter 6: Parameter description <i>P</i> parameter no. 14 and chapter 3: Calibration)
Access	read-write
PDO mapping	no
Data type	Integer32
Default	0
EEPROM	yes
Value range	± 9999999

7.12.2.53 607D_h: Software Position Limit

Via object 607D_h, the software limit switches defining the working range of the drive are set.

Subindex	00 _h
Description	Number of subindexes
Access	read-only
PDO mapping	no
Data type	Integer32
Default	2
EEPROM	no

Subindex	01 _h
Description	Limit 2 (see chapter 6: Parameter description <i>P</i> parameter no. 16)
Access	read-write
PDO mapping	no
Data type	Integer32
Default	-1000000
EEPROM	yes
Value range	± 9999999

Subindex	02 _h
Description	Limit 1 (see chapter 6: Parameter description <i>P</i> parameter no. 15)
Access	read-write
PDO mapping	no
Data type	Integer32
Default	+1000000
EEPROM	yes
Value range	± 9999999

7.12.2.54 607E_h: Polarity

The polarity of the drive's sense of rotation is set via object 607E_h.

Subindex	00 _h
Description	Sense of rotation (see chapter 6: Parameter description <i>P</i> parameter no. 18)
Access	read-write
PDO mapping	no
Data type	Unsigned8
Default	0
EEPROM	yes
Value range	0 ... 1

Data description

Value '0' = sense of rotation 'i'
Value '1' = sense of rotation 'e'

7.12.2.55 6091_h: Gear Ratio

A gear ratio can be programmed via object 6091_h.

Subindex	00 _h
Description	Number of subindexes
Access	read-only
PDO mapping	no
Data type	Unsigned16
Default	2
EEPROM	no

Subindex	01 _h
Description	Numerator gear ratio (see chapter 6: Parameter description <i>P</i> parameter no. 11)
Access	read-write
PDO mapping	no
Data type	Unsigned16
Default	1
EEPROM	yes
Value range	1 ... 10000

Subindex	02 _h
Description	Denominator gear ratio (see chapter 6: Parameter description <i>P</i> parameter no. 12)
Access	read-write
PDO mapping	no
Data type	Unsigned16
Default	1
EEPROM	yes
Value range	1 ... 10000

see also chapter 4: External gear unit.

7.12.2.56 60FF_h: Target Velocity

The target velocity of a drive movement in the operation mode Profile Velocity Mode (velocity mode) is entered via object 60FF_h.

Subindex	00 _h
Description	Target velocity in the velocity mode of operation
Access	read-write
PDO mapping	yes
Data type	Integer32
Default	no
EEPROM	no
Value range	Gear 24:1 ⇒ ± 200 Gear 48:1 ⇒ ± 100

PDO mapping:

The target velocity and the control word of the state machine are mapped on the Receive PDO4, see object 1603_h (4th Receive PDO mapping parameter).

7.13 Setting the node address of the AG03.

The node address can only be set via DIP switches.

After removing the screw plug from the cover of the housing the 10-pin DIP switch will be visible.

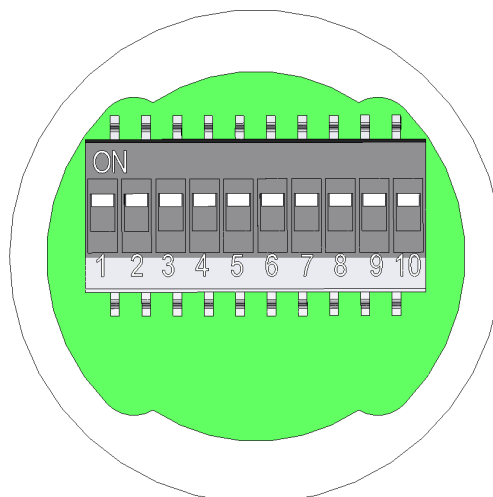

The node address is entered via switches 1 – 7 in binary format.
The setting of address 0 is internally set into address 1.

This is illustrated in the following table:

SW1 [2 ⁰]	SW2 [2 ¹]	SW3 [2 ²]	SW4 [2 ³]	SW5 [2 ⁴]	SW6 [2 ⁵]	SW7 [2 ⁶]	Set slave address
OFF	OFF	OFF	OFF	OFF	OFF	OFF	1!
ON	OFF	OFF	OFF	OFF	OFF	OFF	1
OFF	ON	OFF	OFF	OFF	OFF	OFF	2
ON	ON	OFF	OFF	OFF	OFF	OFF	3
:	:	:	:	:	:	:	:
OFF	OFF	ON	ON	ON	ON	ON	124
ON	OFF	ON	ON	ON	ON	ON	125
OFF	ON	ON	ON	ON	ON	ON	126
ON	ON	ON	ON	ON	ON	ON	127



The DIP switch settings are only read when the supply voltage is switched on. Changing the slave address during operation has no effect.

7.14 Diagnosis LEDs

Various operational states are signalled via the diagnosis LEDs.

	State	Meaning
Status LED (green)	blinking	Drive out of order, meaning: see chapter 5.2.1
	ON	Enable applied
	OFF	No enable or no power supply
BUS LED (orange)	blinking 2.5Hz	Drive is in the pre-operational mode
	ON	Drive is in the operational mode
	blinking (scan ratio 1:5)	Drive is in the stopped mode

7.15 CAN bus termination

The internal bus terminator can be switched in via DIP switches 9 + 10:

SW9	SW10	Bus terminator
OFF	OFF	deactivated
ON	ON	active



It should be noted that both DIP switches are always required for correct funktion of bus termination.