

A-5-4.2 HS Series



(1) Features

1. High motion accuracy

High motion accuracy is achieved in both narrow and wide ranges by adopting ultra-long ball slides and optimum design features for the ball recirculation component.

2. Ball passage vibration reduced to one-third of our conventional models

Tests show ball passage vibration has been reduced to one-third of our conventional models, dramatically improving straightness in table unit.

3. Installation of rail with greater accuracy

Increased counterbore depth of the rail mounting hole reduces rail deflection, which is caused by bolt tightening when fixing the rail to the base component, to 50% or less. This feature restrains the pitching motion of ball slide whose frequency matches to the mounting hole pitch.

In addition, the length of mounting hole pitch has been reduced by one-half of the conventional models, so the rail can be more accurately installed in position.

4. High rigidity and load capacity with lower friction

High rigidity, high load capacity and low friction are achieved by increasing the number of balls.

5. Compact design

Reduced body size enables more compact compact machinery.

6. High load carrying capacity to vertical direction

The contact angle is set at 50 degrees, increasing load carrying capacity as well as rigidity against the load in vertical direction.

7. High resistance against impact load

The bottom ball groove is formed in Gothic arch and the center of the top and bottom grooves are offset as shown in Fig. 2. The vertical load is usually carried by top 2 rows at where balls are contacting at two points. Because of this design, the bottom rows will carry the load when a large impact load is applied as shown in Fig. 3. This assures high

resistance to the impact load.

8. High accuracy at manufacturing

As showing in Fig. 4, fixing the measuring rollers is simple thanks to the Gothic arch groove. This makes easy and accurate measuring of ball grooves.

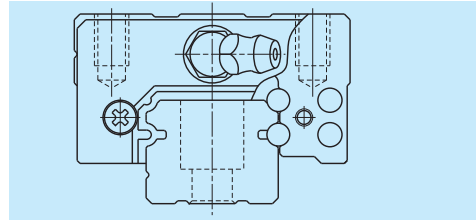

Fig. 1 HS Series

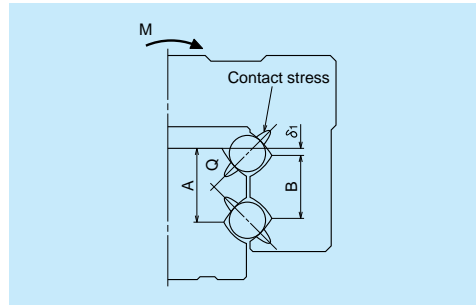

Fig. 2 Enlarged illustration: Offset Gothic arch

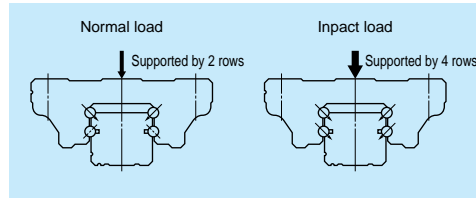

Fig. 3 When load is applied

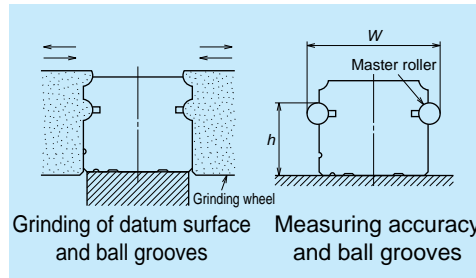

Fig. 4 Rail-grinding and measuring

Measurement results of ball passage vibration

Ball passage vibration can translate into posture changes in the ball slide which result from ball passage (circulation). In the HS Series, this vibration has been substantially reduced to one-third of conventional models.

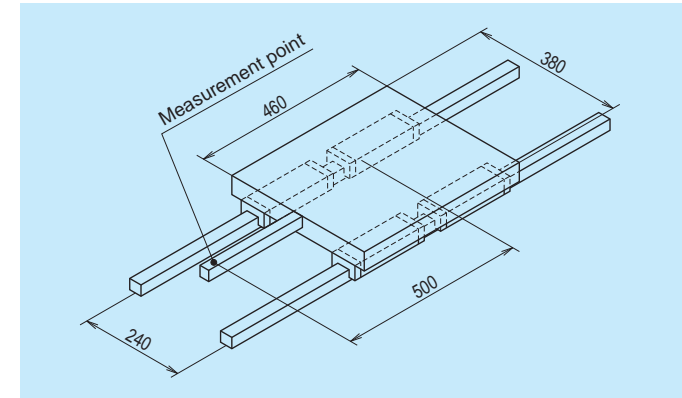

Fig. 5 Schematic view of measurement of ball passage vibration

HS Series

Model No.: HS30

Preload: Z1

Table dimensions: 460 mm x 380 mm

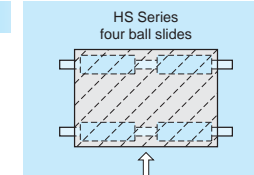

The same table is used.

Straightness

0.12 μm

Strokes: 200 mm

Conventional Series

Model No.: LS30

Preload: Z1

Table dimensions: 460 mm x 380 mm

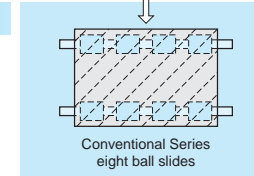

Straightness

0.36 μm

Strokes: 200 mm

Fig. 6 Measurement results of HS Series and conventional Series

(2) Ball slide shape

Ball slide Model	Shape/installation method	Type
AL		
EM		

(3) Accuracy and preload

1. Running parallelism of ball slide

Table 1 Unit: μm

Rail over all length (mm) over or less	Preloaded assembly		
	Ultra precision P3	Super precision P4	High precision P5
- 200	2	2	4
200 - 250	2	2.5	5
250 - 315	2	2.5	5
315 - 400	2	3	6
400 - 500	2	3	6
500 - 630	2	3.5	7
630 - 800	2	4.5	8
800 - 1 000	2.5	5	9
1 000 - 1 250	3	6	10
1 250 - 1 600	4	7	11
1 600 - 2 000	4.5	8	13
2 000 - 2 500	5	10	15
2 500 - 3 150	6	11	17
3 150 - 4 000	9	16	23

2. Accuracy Standard

Three accuracy grades are available: ultra precision P3, super precision P4 and high precision P5.

Table 2 Unit: μm

Characteristics	Ultra precision P3	Super precision P4	High precision P5
Mounting height H	± 10	± 10	± 20
Variation of H (All ball slides on a set of rails)	3	5	7
Mounting width W_2 or W_3	± 15	± 15	± 25
Variation of W_2 or W_3 (All ball slides on reference rail)	3	7	10
Running parallelism of face C to face A Running parallelism of face D to face B	Refer to Table 1 and Fig. 7		

3. Assembled accuracy

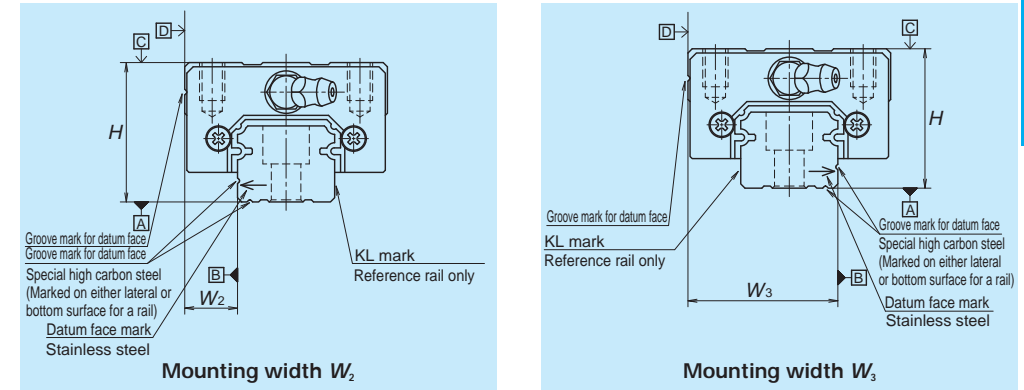

Fig. 7

4. Preload and rigidity

Slight preload Z1 and medium preload Z3 are available for preload, which can be selected for specific applications.

Table 3

Model No.	Preload (N)		Rigidity (N/ μm)	
	Slight preload (Z1)	Medium preload (Z3)	Slight preload (Z1)	Medium preload (Z3)
HS15	98	785	260	530
HS20	147	1 030	305	600
HS25	245	1 620	385	735
HS30	390	2 550	505	965
HS35	590	3 550	610	1 140

(4) Available length of rail

Table 4 shows the limitation of rail length (maximum length). The dimension in parenthesis is for stainless. However, the limitations vary by accuracy grade.

Table 4 Unit: mm

Series	Size	15	20	25	30	35
HS		2000 (1700)	3960 (3500)	3960 (3500)	4000 (3500)	4000 (3500)

Note: Rails can be butted if user requirement exceeds the rail length shown in the Table. Please consult NSK.

(5) Installation

1. Permissible values of mounting error

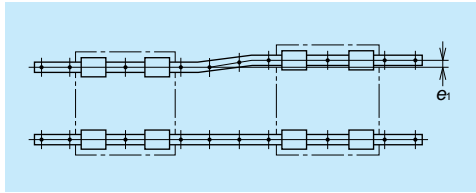

Fig. 8

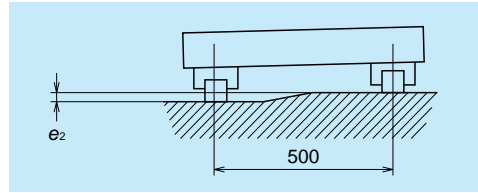

Fig. 9

Table 5

Unit: μm

Value	Preload	Model No.				
		HS15	HS20	HS25	HS30	HS35
Permissible values of parallelism in two rails e_1	Z1	18	20	26	31	37
	Z3	12	14	18	22	26
Permissible values of parallelism (height) in two rails e_2	Z1, Z3	330 $\mu\text{m}/500 \text{ mm}$				

2. Shoulder height of the mounting face and corner radius r

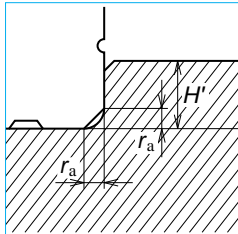

Fig. 10 Shoulder for the rail datum face

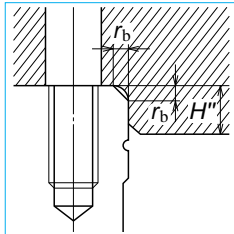

Fig. 11 Shoulder for the ball slide datum face

Table 6 Height of the shoulder and corner radius of the mounting face

Unit: mm

Model No.	Corner radius (maximum)		Shoulder height	
	r_a	r_b	H'	H''
HS15	0.5	0.5	4	4
HS20	0.5	0.5	4.5	5
HS25	0.5	0.5	5	5
HS30	0.5	0.5	6	6
HS35	0.5	0.5	6	6

(6) Lubrication components

Refer to Page A38 and D13 for linear guide lubrication.

1. Types of lubrication accessories

Figure 12 and Table 7 show grease fittings and tube fittings.

We provide lubrication accessories with extended thread body length (L) for the addition of dust proof accessories such as NSK K1 lubrication unit, double seal and protector.

We provide a suitable lubrication accessory for the special requirement on dust proof accessories.

Consult NSK for a lubrication accessory with extended length of thread body for your convenience of replenishing lubricant.

Please ask NSK for stainless lubrication accessories.

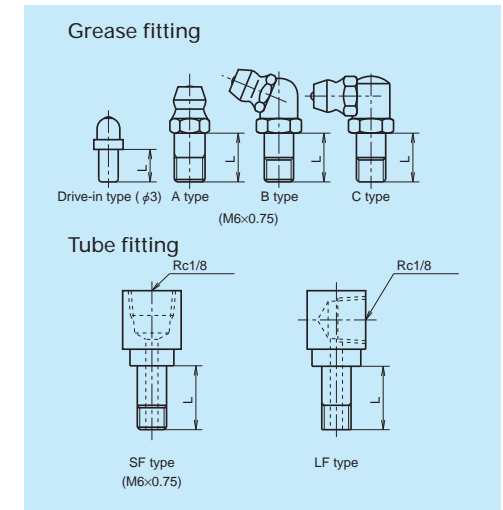

Fig. 12 Grease fitting and tube fitting

2. Mounting position of lubrication accessories

The standard position of grease fittings is the end face of ball slide. We mount them on a side of end cap for an option.

Please consult NSK for installation of grease or tube fittings to the ball slide body or side of end cap.

When using a piping unit with thread of M6 \times 1, you require a connector to connect to a grease fitting mounting hole with M6 \times 0.75. The connector is available from NSK.

Table 7

Unit: mm

Model No.	Dust-proof specification	Grease fitting	Tube fitting
		Drive-in Thread body length L	Thread body length L
HS15	Standard	5	-
	With NSK K1	10	-
	Double seal	*	-
	Protector	*	-
HS20	Standard	5	-
	With NSK K1	10	-
	Double seal	8	-
	Protector	8	-
HS25	Standard	5	6
	With NSK K1	12	11
	Double seal	10	9
	Protector	10	9
HS30	Standard	5	6
	With NSK K1	14	13
	Double seal	12	11
	Protector	12	11
HS35	Standard	5	6
	With NSK K1	14	13
	Double seal	12	11
	Protector	12	11

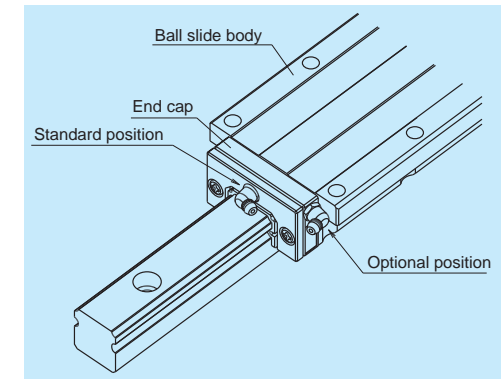

Fig. 13 Mounting position of lubrication accessories

*) Please contact NSK as a connector is required.

(7) Dust-proof components

1. Standard Specification

To keep foreign matters from entering inside the ball slide, HS Series has an end seal on both ends.

Bottom seal is equipped on bottom as an option.

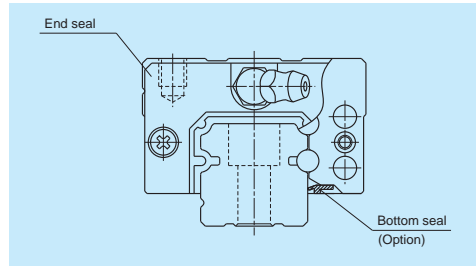

Fig. 14

Table 8 Seal friction per ball slide (maximum): end seal only

		Unit: N				
Series	Size	15	20	25	30	35
HS		3	3	3	3	4

2. NSK K1™

Refer to Table 9 for dimension of linear guides equipped with the NSK K1.

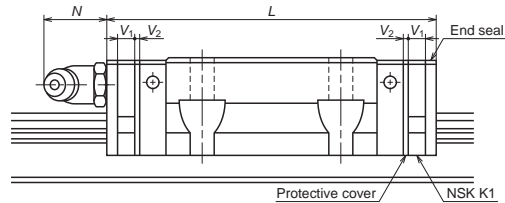

Table 9

		Unit: mm				
Model No.	Ball slide model	Standard ball slide length	Ball slide length installed with two NSK K1 L	Per NSK K1 thickness V ₁	Protective cover thickness V ₂	Protruding area of the grease fitting N
HS15	AL, EM	106	115.6	4.0	0.8	(5)
HS20	AL, EM	119.7	130.3	4.5	0.8	(14)
HS25	AL, EM	148	158.6	4.5	0.8	(14)
HS30	AL, EM	176.1	188.1	5.0	1.0	(14)
HS35	AL, EM	203.6	216.6	5.5	1.0	(14)

Note: Ball slide length equipped with NSK K1 = (Standard ball slide length) + (Thickness of NSK K1, V₁ × Number of NSK K1) + (Thickness of the protective cover V₂ × 2)

3. Double seal and protector

For HS series, double seal and protector can be installed only before shipping from the factory. Please consult with NSK.

Table 10 shows the increased thickness of V₁, and V₂ when end seal and protector are installed.

Table 10

		Unit: mm	
Model No.	Thickness of end seal: V ₁	Thickness of protector: V ₂	
HS15	2.8	3	
HS20	2.5	2.7	
HS25	2.8	3.2	
HS30	3.6	4.2	
HS35	3.6	4.2	

4. Caps to cover the bolt hole for rail mounting

Table 12 shows size of the bolts for the each model number as well as reference number of the cap.

Table 11 Caps to cover rail bolt hole

Model No.	Bolt to secure rail	Cap reference No.	Quantity /case
HS15	M3	LG-CAP/M3	20
HS15	M4	LG-CAP/M4	20
HS20	M5	LG-CAP/M5	20
HS25, HS30	M6	LG-CAP/M6	20
HS35	M8	LG-CAP/M8	20

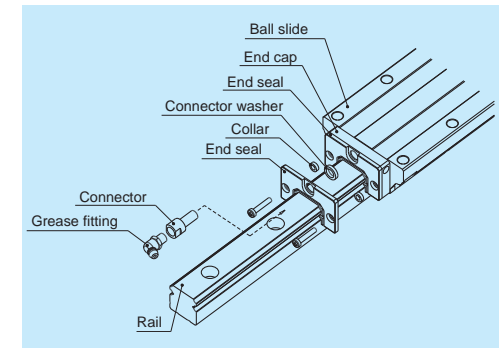

Fig. 15 Double seal

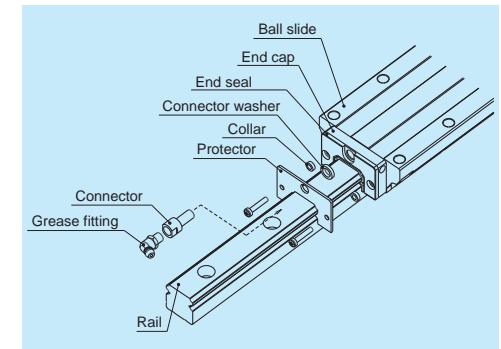

Fig. 16 Protector

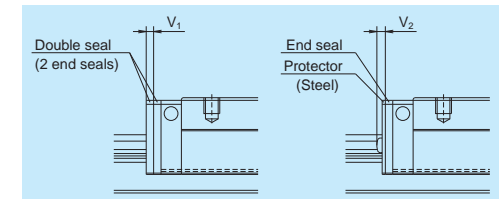

Fig. 17

(8) Reference number

Reference numbers shall be set to individual NSK linear guide when its specifications are finalized, and it is indicated on its specification drawing.

Please specify the reference number, except design serial number, to identify the product when ordering, requiring estimates, or inquiring about specifications from NSK.

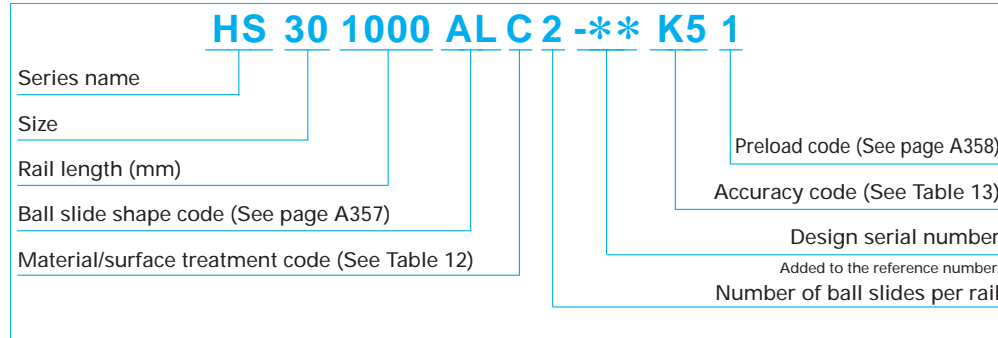

Table 12 Material/surface treatment code

Code	Description
C	Special high carbon steel (NSK standard)
K	Stainless steel
D	Special high carbon steel with surface treatment
H	Stainless steel with surface treatment
Z	Other, special

Table 13 Accuracy code

Accuracy	Standard (Without NSK K1)	With NSK K1
Ultra precision grade	P3	K3
Super precision grade	P4	K4
High precision grade	P5	K5

Note: Refer to Page A38 for NSK K1 lubrication unit.

(9) Dimensions

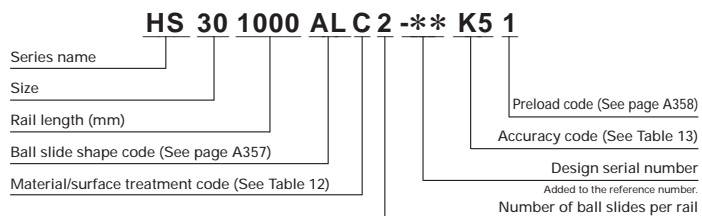

Front view of AL types

Side view of AL type

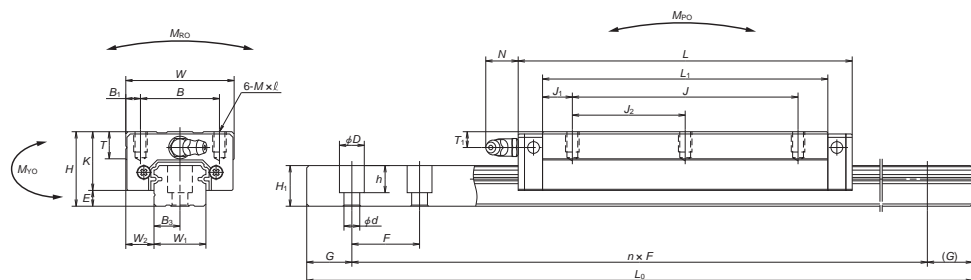

Model No.	Assembly			Ball slide													
	Height H	E	W_2	Width W	Length L	Mounting hole								Grease fitting			
						B	J	J_2	$M \times \text{pitch} \times \ell$	B_1	L_1	J_1	K	T	Hole size	T_1	N
HS15AL	24	4.6	9.5	34	106	26	60	30	M4×0.7×6	4	89.2	14.6	19.4	10	$\phi 3$	6	3
HS20AL	28	6	11	42	119.7	32	80	40	M5×0.8×7	5	102.5	11.25	22	12	M6×0.75	5.5	11
HS25AL	33	7	12.5	48	148	35	100	50	M6×1×9	6.5	126.4	13.2	26	12	M6×0.75	7	11
HS30AL	42	9	16	60	176.1	40	120	60	M8×1.25×12	10	150.7	15.35	33	13	M6×0.75	8	11
HS35AL	48	10.5	18	70	203.6	50	140	70	M8×1.25×12	10	175.6	17.8	37.5	14	M6×0.75	8.5	11

Remarks: 1) HS Series does not have a ball retainer. Be aware that balls fall out when the ball slider is withdrawn from the rail.
 2) The external appearance of stainless steel ball slides differ from those of standard material ball slide.

Unit: mm

Rail							Basic load rating					Ball dia.	Weight	
Width W_1	Height H_1	Pitch F	Mounting Bolt hole $d \times D \times h$	B_3	G	Maximum length L_{max} (1) for stainless	Dynamic C (N)	Static C_0 (N)	Static moment			Ball slide D_w	Ball (g)	Rail (kg/m)
					(Reference)				M_{Ro}	M_{Po}	M_{Vo}			
15	12.5	30	*3.5×6×8.5 4.5×7.5×8.5	7.5	20	2 000 (1 700)	15 300	40 000	199	395	335	2.778	0.34	1.4
20	15.5	30	6×9.5×10.5	10	20	3 960 (3 500)	20 400	52 000	350	590	495	3.175	0.52	2.3
23	18	30	7×11×12	11.5	20	3 960 (3 500)	32 000	78 000	605	1 090	910	3.968	0.85	3.1
28	23	40	7×11×16	14	20	4 000 (3 500)	51 500	127 000	1 190	2 120	1 780	4.762	1.7	4.8
34	27.5	40	9×14×20	17	20	4 000 (3 500)	71 500	172 000	1 980	3 350	2 820	5.556	2.5	7.0

3) The basic dynamic load rating is a load that furnishes 50 km rating fatigue life; it is a vertical and constant load to the ball slide mounting surface. When converting the basic dynamic load rating C to the dynamic load rating C_{100} for 100 km rating fatigue life, divide the C by 1.26.

*) The standard rail mounting bolt hole for HS15 is specified as the hole for M3 (3.5×6×8.5). Please contact us to request a different hole for M4 (4.5×7.5×8.5).

Parenthesized dimensions are applicable to stainless steel products.

HS 30 1000 EMC 2 - K5 1**

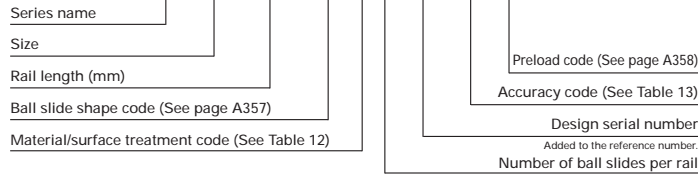

Front view of EM type

Side view of EM type

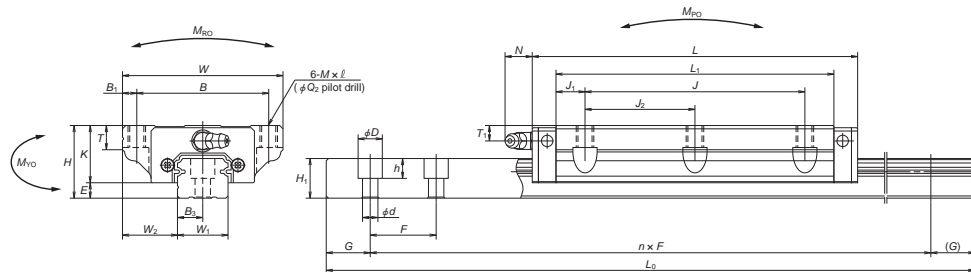

Model No.	Assembly			Ball slide														
	Height H	E	W ₂	Width W	Length L	Mounting hole						Grease fitting						
						B	J	J ₂	M x pitch x l	Q ₂	B ₁	L ₁	J ₁	K	T	Hole size	T ₁	N
HS15EM	24	4.6	18.5	52	106	41	60	30	M5x0.8x7	4.4	5.5	89.2	14.6	19.4	8	φ 3	6	3
HS20EM	28	6	19.5	59	119.7	49	80	40	M6x1x9 (M6x1x9.5)	5.3	5	102.5	11.25	22	10	M6x0.75	5.5	11
HS25EM	33	7	25	73	148	60	100	50	M8x1.25x10 (M8x1.25x11.5)	6.8	6.5	126.4	13.2	26	11 (12)	M6x0.75	7	11
HS30EM	42	9	31	90	176.1	72	120	60	M10x1.5x12 (M10x1.5x14.5)	8.6	9	150.7	15.35	33	11 (15)	M6x0.75	8	11
HS35EM	48	10.5	33	100	203.6	82	140	70	M10x1.5x13 (M10x1.5x14.5)	8.6	9	175.6	17.8	37.5	12 (15)	M6x0.75	8.5	11

Remarks: 1) HS Series does not have a ball retainer. Be aware that balls fall out when the ball slider is withdrawn from the rail.
 2) The external appearance of stainless steel ball slides differ from those of standard material ball slide.
 3) Parenthesized dimensions are applicable to stainless steel products.

Unit: mm

Rail							Basic load rating					Ball dia.	Weight	
Width W ₁	Height H ₁	Pitch F	Mounting Bolt hole d x D x h	B ₃	G	Maximum length L _{0max} (1) for stainless	Dynamic C (N)	Static C ₀ (N)	Static moment			D _w	Ball slide (kg)	Rail (kg/m)
									M _{Ro} (N·m)	M _{po} (N·m)	M _{vo} (N·m)			
15	12.5	30	*3.5x6x8.5 4.5x7.5x8.5	7.5	20	2 000 (1 700)	15 300	40 000	199	395	335	2.778	0.45	1.4
20	15.5	30	6x9.5x10.5	10	20	3 960 (3 500)	20 400	52 000	350	590	495	3.175	0.67	2.3
23	18	30	7x11x12	11.5	20	3 960 (3 500)	32 000	78 000	605	1 090	910	3.968	1.3	3.1
28	23	40	7x11x16	14	20	4 000 (3 500)	51 500	127 000	1 190	2 120	1 780	4.762	2.4	4.8
34	27.5	40	9x14x20	17	20	4 000 (3 500)	71 500	172 000	1 980	3 350	2 820	5.556	3.4	7.0

4) The basic dynamic load rating is a load that furnishes 50 km rating fatigue life; it is a vertical and constant load to the ball slide mounting surface. When converting the basic dynamic load rating C to the dynamic load rating C₁₀₀ for 100 km rating fatigue life, divide the C by 1.26.
 *) The standard rail mounting bolt hole for HS15 is specified as the hole for M3 (3.5x6x8.5). Please contact us to request a different hole for M4 (4.5x7.5x8.5).
 Parenthesized dimensions are applicable to stainless steel products.