

### A-5-1.4 LS Series

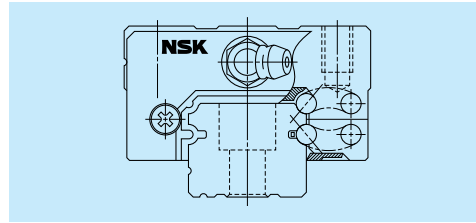
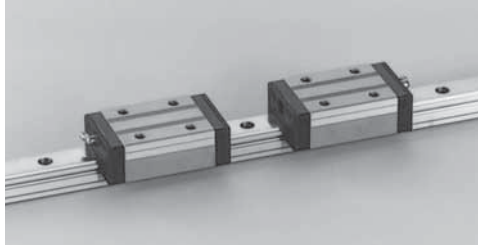

Fig. 1 LS Series

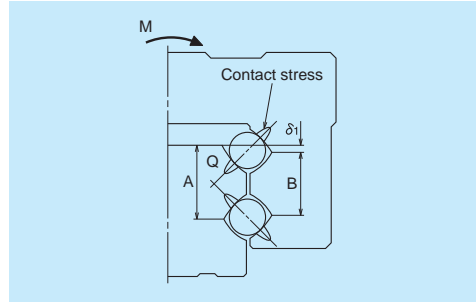

Fig. 2 Enlarged illustration of the offset Gothic arch groove

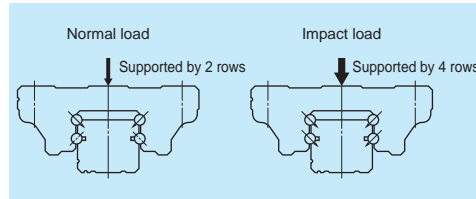

Fig. 3 When load is applied

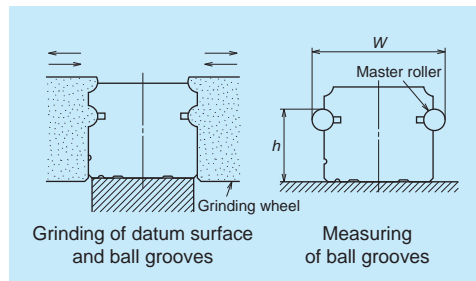

Fig. 4 Rail-grinding and measuring

#### (1) Features

##### 1. High self aligning capability (rolling direction)

Same as the DF combination in angular contact bearings, self-aligning capability is high because the cross point of the contact lines of balls and grooves comes inside, reducing moment rigidity. This increases the capacity to absorb errors in installation.

##### 2. High load carrying capacity to vertical direction

The contact angle is set at 50 degrees, increasing load carrying capacity as well as rigidity against the load in vertical direction.

##### 3. High resistance against impact load

The bottom ball groove is formed in Gothic arch and the center of the top and bottom grooves are offset as shown in Fig. 2. The vertical load is usually carried by top 2 rows, where balls are contacting at two points. Because of this design, the bottom rows will carry the load when a large impact load is applied as shown in Fig. 3. This assures high resistance to the impact load.

##### 4. High accuracy

As showing in Fig. 4, fixing the measuring rollers is simple thanks to the Gothic arch groove. This makes easy and accurate measuring of ball-grooves.

##### 5. Easy to handle, and designed with safety in mind.

Balls are retained in the retainer and do not fall out when the ball slide is withdrawn from the rail.

##### 6. Abundant models and sizes come in series.

Each series has several ball slide models, rendering the linear guide available for numerous uses. The LS Series also has standardized long stainless-steel rail (maximum: 3 500 mm).

##### 7. Fast delivery

Lineup of random-matching rails and ball slides supports and facilitates fast delivery.

#### (2) Ball slide shape

Ball slide Model	Shape/installation method	Type	
		Medium-load type	High-load type
AL CL		CL 	AL 
EL JL		JL 	EL 
FL KL		KL 	FL 
EM JM		JM 	EM 

(3) Accuracy and preload

1. Running parallelism of ball slide

Table 1

Unit:  $\mu\text{m}$

Rail over all length (mm) over or less	Preloaded assembly (not random matching)						Random-matching type
	Ultra precision P3	Super precision P4	High precision P5	Precision grade P6	Normal grade PN	Normal grade PC	
- 50	2	2	2	4.5	6	6	
50 - 80	2	2	3	5	6	6	
80 - 125	2	2	3.5	5.5	6.5	6.5	
125 - 200	2	2	4	6	7	7	
200 - 250	2	2.5	5	7	8	8	
250 - 315	2	2.5	5	8	9	9	
315 - 400	2	3	6	9	11	11	
400 - 500	2	3	6	10	12	12	
500 - 630	2	3.5	7	12	14	14	
630 - 800	2	4.5	8	14	16	16	
800 - 1000	2.5	5	9	16	18	18	
1000 - 1250	3	6	10	17	20	20	
1250 - 1600	4	7	11	19	23	23	
1600 - 2000	4.5	8	13	21	26	26	
2000 - 2500	5	10	15	22	29	29	
2500 - 3150	6	11	17	25	32	32	
3150 - 4000	9	16	23	30	34	34	

2. Accuracy standard

The preloaded assembly has five accuracy grades; Ultra precision P3, Super precision P4, High precision P5, Precision P6 and Normal PN grades, while the random-matching type has Normal PC grade.

• Tolerance of preloaded assembly

Table 2

Unit:  $\mu\text{m}$

Characteristics	Accuracy grade	Ultra precision P3	Super precision P4	High precision P5	Precision grade P6	Normal grade PN
Mounting height $H$ Variation of $H$ (All ball slides on a set of rails)		$\pm 10$ 3	$\pm 10$ 5	$\pm 20$ 7	$\pm 40$ 15	$\pm 80$ 25
Mounting width $W_2$ or $W_3$ Variation of $W_2$ or $W_3$ (All ball slides on reference rail)		$\pm 15$ 3	$\pm 15$ 7	$\pm 25$ 10	$\pm 50$ 20	$\pm 100$ 30
Running parallelism of face C to face A Running parallelism of face D to face B		See Table 1, Fig. 5 and Fig. 6				

• Tolerance of random-matching type: Normal grade PC

Table 3

Unit:  $\mu\text{m}$

Characteristics	Model No.	LS15, 20, 25, 30, 35
Mounting height $H$		$\pm 20$
Variation of mounting height $H$		15 <sup>①</sup> 30 <sup>②</sup>
Mounting width $W_2$ or $W_3$		$\pm 30$
Variation of mounting width $W_2$ or $W_3$		25
Running parallelism of face C to face A Running parallelism of face D to face B		See Table 1, Fig. 5 and Fig. 6

Note: ① Variation on the same rail  
② Variation on multiple rails

3. Combinations of accuracy and preload

Table 4

	Accuracy grade						
	Ultra precision	Super precision	High precision	Precision grade	Normal grade	Normal grade	
Without NSK K1 lubrication unit	P3	P4	P5	P6	PN	PC	
With NSK K1 lubrication unit	K3	K4	K5	K6	KN	KC	
With NSK K1 for food and medical equipment	F3	F4	F5	F6	FN	FC	
Preload	Fine clearance Z0	○	○	○	○	○	—
	Slight preload Z1	○	○	○	○	○	—
	Medium preload Z3	○	○	○	○	—	—
	Random-matching type with fine clearance ZT	—	—	—	—	—	○
	Random-matching type with slight preload ZZ	—	—	—	—	—	○

4. Assembled accuracy

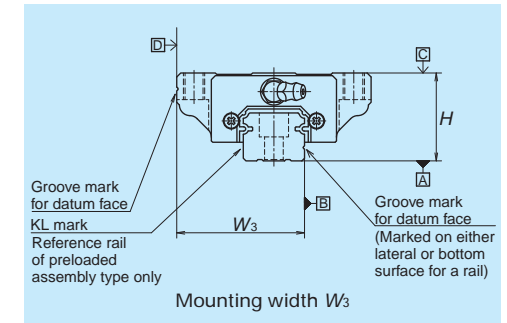
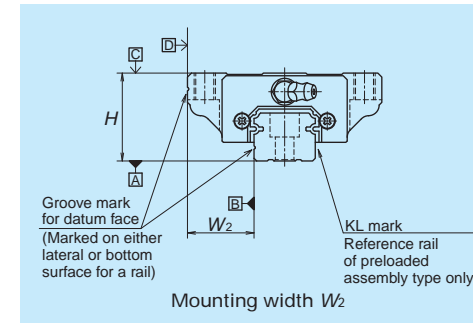

Fig. 5 Special high carbon steel

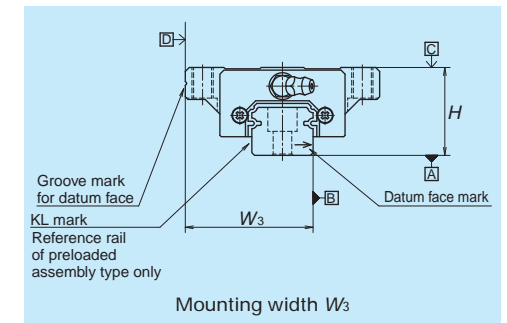
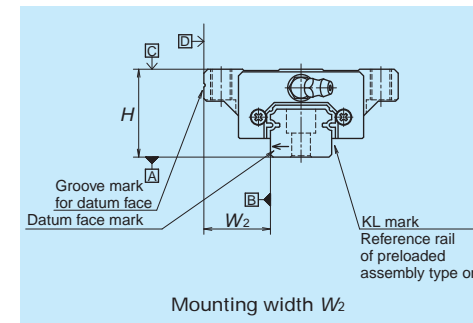

Fig. 6 Stainless steel

### 5. Preload and rigidity

We offer five levels of preload: slight preload Z1, medium preload Z3 and fine clearance Z0, along with random-matching type of fine clearance ZT and slight preload ZZ. Values for preload and rigidity of the preloaded assembly are shown in Table 5. Rigidities are for the median of the preload range.

• Preload and rigidity of preloaded assembly

Table 5

Model No.	Preload (N)		Rigidity (N/μm)			
	Slight preload Z1	Medium preload Z3	Vertical direction		Lateral direction	
			Slight preload Z1	Medium preload Z3	Slight preload Z1	Medium preload Z3
High-load type LS15 AL, EL, FL, EM LS20 AL, EL, FL, EM LS25 AL, EL, FL, EM LS30 AL, EL, FL, EM LS35 AL, EL, FL, EM	69	390	127	226	88	167
	88	540	147	284	108	206
	147	880	206	370	147	275
	245	1370	255	460	186	345
	345	1960	305	550	216	400
Medium-load type LS15 CL, JL, KL, JM LS20 CL, JL, KL, JM LS25 CL, JL, KL, JM LS30 CL, JL, KL, JM LS35 CL, JL, KL, JM	49	294	78	147	59	108
	69	390	108	186	78	137
	98	635	127	235	88	177
	147	980	147	275	108	206
	245	1370	186	335	137	245

Note: Clearance for fine clearance Z0 is 0 to 3μm. Therefore, preload is zero. However, Z0 of PN grade is 0 to 15μm.

• Clearance and preload of random-matching type

Table 6

Unit: μm

Model No.	Fine clearance	Slight preload
	ZT	ZZ
LS15	-4 - 15	-4 - 0
LS20	-4 - 15	-4 - 0
LS25	-5 - 15	-5 - 0
LS30	-5 - 15	-5 - 0
LS35	-5 - 15	-6 - 0

Note: Minus sign denotes that a value is an amount of preload (elastic deformation of balls).

### (4) Available length of rail

Table 7 shows the limitations of rail length (maximum length). However, the limitations vary by accuracy grade.

Table 7 Length limitations of rails

Unit: mm

Series	Material	Size				
		15	20	25	30	35
LS	Special high carbon steel	2000	3960	3960	4000	4000
	Stainless steel	1700	3500	3500	3500	3500

Note: Rails can be butted if user requirement exceeds the rail length shown in the Table. Please consult NSK.

### (5) Installation

#### 1. Permissible values of mounting error

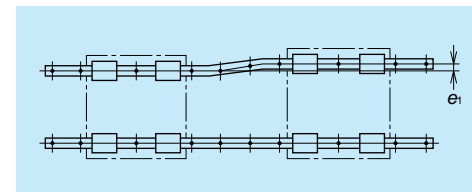

Fig. 7

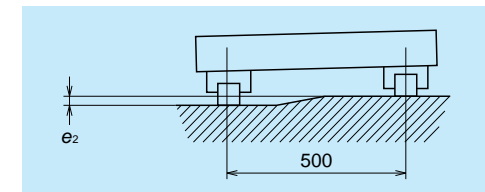

Fig. 8

Table 8

Unit: μm

Value	Preload	Model No.				
		LS15	LS20	LS25	LS30	LS35
Permissible values of parallelism in two rails e <sub>1</sub>	Z0, ZT	20	22	30	35	40
	Z1, ZZ	15	17	20	25	30
	Z3	12	15	15	20	25
Permissible values of parallelism (height) in two rails e <sub>2</sub>	Z0, ZT	375 μm/500 mm				
	Z1, ZZ, Z3	330 μm/500 mm				

#### 2. Shoulder height of the mounting face and corner radius r

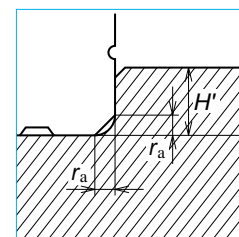

Fig. 9 Shoulder for the rail datum face

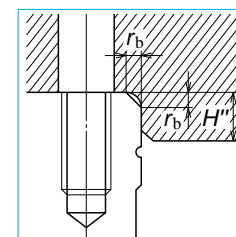

Fig. 10 Shoulder for the ball slide datum face

Table 9

Unit: mm

Model No.	Corner radius (maximum)		Shoulder height	
	r <sub>a</sub>	r <sub>b</sub>	H'	H''
LS15	0.5	0.5	4	4
LS20	0.5	0.5	4.5	5
LS25	0.5	0.5	5	5
LS30	0.5	0.5	6	6
LS35	0.5	0.5	6	6

## (6) Lubrication components

Refer to page A38 and D13 for the lubrication of linear guides.

### 1. Types of lubrication accessories

Figure 11 and Table 10 show grease fittings and tube fittings.

We provide lubrication accessories with extended thread body length (L) for the addition of dust proof accessories such as NSK K1 lubrication unit, double seal and protector.

We provide a suitable lubrication accessory for the special requirement on dust proof accessories.

Consult NSK for a lubrication accessory with extended length of thread body for your convenience of replenishing lubricant.

Please ask NSK for stainless lubrication accessories.

### 2. Mounting position of lubrication accessories

The standard position of grease fittings is the end face of ball slide. We mount them on a side of end cap for an option. (Fig. 12)

Please consult NSK for installation of grease or tube fittings to the ball slide body or side of end cap.

When using a piping unit with thread of M6×1, you require a connector to connect to a grease fitting mounting hole with M6 × 0.75. The connector is available from NSK.

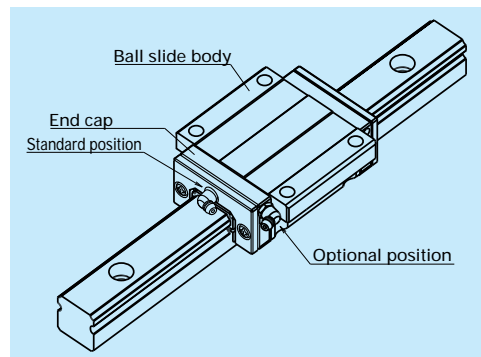

Fig. 12 Mounting position of lubrication accessories

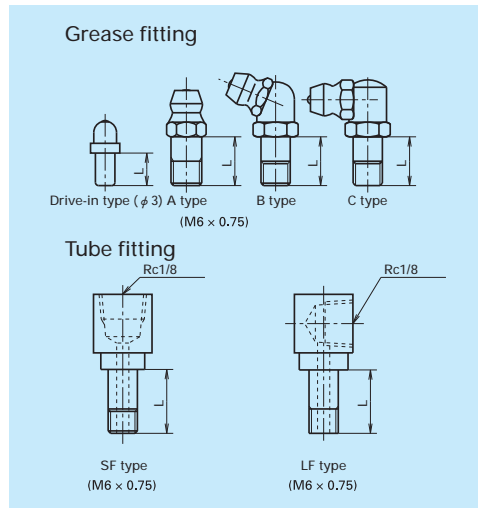

Fig. 11 Grease fitting and tube fitting

Model No.	Dust proof specification	Grease fitting	Tube fitting
		Thread body length L	Thread body length L
LS15	Standard	5	-
	With NSK K1	10	-
	Double seal	*	-
	Protector	*	-
LS20	Standard	5	-
	With NSK K1	10	-
	Double seal	8	-
	Protector	8	-
LS25	Standard	5	6
	With NSK K1	12	11
	Double seal	10	9
	Protector	10	9
LS30	Standard	5	6
	With NSK K1	14	13
	Double seal	12	11
	Protector	12	11
LS35	Standard	5	6
	With NSK K1	14	13
	Double seal	12	11
	Protector	12	11

\*) Please contact NSK as a connector is required.

## (7) Dust proof components

### 1. Standard specification

To keep foreign matters from entering inside the ball slide, LS Series has an end seal on both ends, and bottom seals at the bottom.

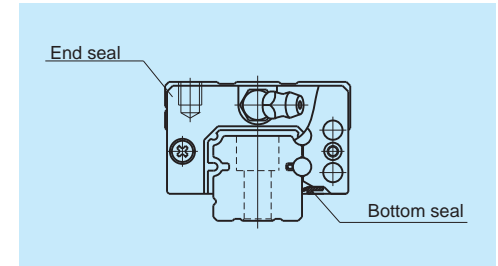

Fig. 13

Table 11 Seal friction per ball slide (maximum value)

Series	Size	Unit : N				
		15	20	25	30	35
LS		8	9	9	9	10

### 2. NSK K1™

Table 12 shows the dimension of linear guides equipped with the NSK K1.

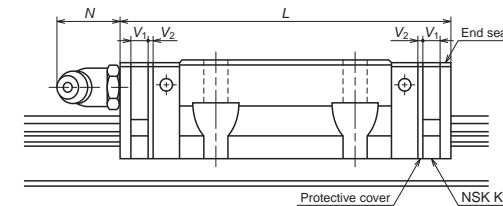

Table 12

Model No.	Ball slide length	Ball slide model	Standard ball slide length	Ball slide length installed with two NSK K1 L	Unit: mm		Protruding area of the grease fitting N
					Per NSK K1 thickness V <sub>1</sub>	Protective cover thickness V <sub>2</sub>	
LS15	Standard	AL, EL, FL, EM	56.8	66.4	4.0	0.8	(5)
	Short	CL, JL, KL, JM	40.4	50			
LS20	Standard	AL, EL, FL, EM	65.2	75.8	4.5	0.8	(14)
	Short	CL, JL, KL, JM	47.2	57.8			
LS25	Standard	AL, EL, FL, EM	81.6	92.2	4.5	0.8	(14)
	Short	CL, JL, KL, JM	59.6	70.2			
LS30	Standard	AL, EL, FL, EM	96.4	108.4	5.0	1.0	(14)
	Short	CL, JL, KL, JM	67.4	79.4			
LS35	Standard	AL, EL, FL, EM	108	121	5.5	1.0	(14)
	Short	CL, JL, KL, JM	77	90			

Note: Ball slide length equipped with NSK K1 = (Standard ball slide length) + (Thickness of NSK K1, V<sub>1</sub> × Number of NSK K1) + (Thickness of the protective cover, V<sub>2</sub> × 2)

### 3. Double seal

Use a double seal set as showing in Table 13, when installing an extra seal to completed standard products. (Fig. 14)

When installing a grease fitting after the installation of double seals, a connector is required.

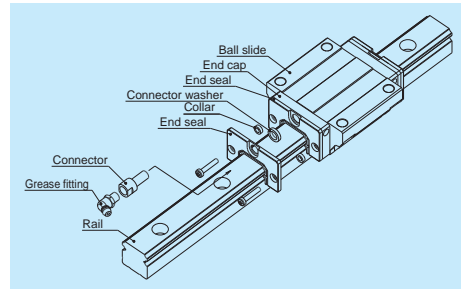

Fig. 14 Double seal

### 4. Protector

Use a protector set as showing Table 14, when installing a protector to completed standard products. (Fig.15)

When installing a grease fitting after the installation of protectors, a connector is required.

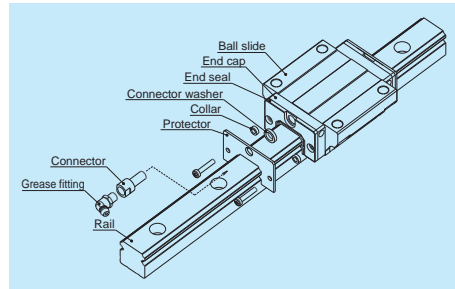

Fig. 15 Protector

Table 13 Double-seal set

Model No.	Reference No.		Increased thickness $V_1$
	Without connector	With connector	
LS15	LS15WS-01	*	2.8
LS20	LS20WS-01	LS20WSC-01	2.5
LS25	LS25WS-01	LS25WSC-01	2.8
LS30	LS30WS-01	LS30WSC-01	3.6
LS35	LS35WS-01	LS35WSC-01	3.6

Table 14 Protector set

Model No.	Reference No.		Increased thickness $V_2$
	Without connector	With connector	
LS15	LS15PT-01	*	3
LS20	LS20PT-01	LS20PTC-01	2.7
LS25	LS25PT-01	LS25PTC-01	3.2
LS30	LS30PT-01	LS30PTC-01	4.2
LS35	LS35PT-01	LS35PTC-01	4.2

\*) For installation of a connector to a drive-in type grease fitting, contact NSK.

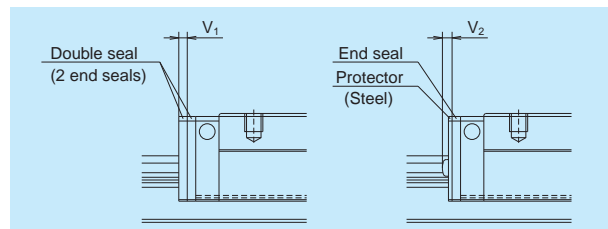

Fig. 16

### 5. Cap to cover the bolt hole for rail mounting

Table 15 Caps to cover rail bolt hole

Model No.	Bolt to secure rail	Cap reference No.	Quantity /case
LS15	M3	LG-CAP/M3	20
LS15	M4	LG-CAP/M4	20
LS20	M5	LG-CAP/M5	20
LS25, LS30	M6	LG-CAP/M6	20
LS35	M8	LG-CAP/M8	20

### 7. Bellows

Use a bellows fastener kit as showing Table 17, when installing bellows to completed standard products. A bellows fastener kit is supplied with one of bellows fastener, two of M1 set screws, two of M2 set screws, and two collars for M2 set screw.

### 6. Inner seal

Inner seal can be manufactured for models shown below.

Table 16

Series	Model No.
LS	LS20, LS25, LS30, LS35

Table 17 Bellows fastener kit reference No.

Model No.	Kit reference No.
LS15	LS15FS-01
LS20	LS20FS-01
LS25	LS25FS-01
LS30	LS30FS-01
LS35	LS35FS-01

Dimension tables of bellows  
LS Series

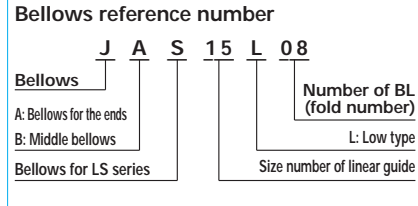
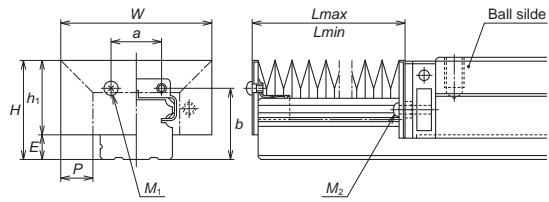

Fig. 17 Dimensions of bellows

Table 18 Dimensions of bellows

Unit: mm

Model No.	H	h <sub>1</sub>	E	W	P	a	b	BL minimum length	M <sub>1</sub> Tap x depth	M <sub>2</sub> Tap x depth
JAS15L	23.5	18.9	4.6	43	10	8	16.5	17	M3x5	M3x14
JAS20L	27	21	6	48	10	13	19.7	17	M3x5	M2.5x14
JAS25L	32	25	7	51	10	15	23.2	17	M3x5	M3x18
JAS30L	41	32	9	66	15	16	29	17	M4x6	M4x19
JAS35L	47	36.5	10.5	72	15	22	33.5	17	M4x6	M4x22

Table 19 Numbers of folds (BL) and lengths of bellows

Unit: mm

Model No.	Number of BL	2	4	6	8	10	12	14	16	18	20
		L <sub>min</sub>	34	68	102	136	170	204	238	272	306
JAS15L	Stroke	106	212	318	424	530	636	742	848	954	1060
	L <sub>max</sub>	140	280	420	560	700	840	980	1120	1260	1400
JAS20L	Stroke	106	212	318	424	530	636	742	848	954	1060
	L <sub>max</sub>	140	280	420	560	700	840	980	1120	1260	1400
JAS25L	Stroke	106	212	318	424	530	636	742	848	954	1060
	L <sub>max</sub>	140	280	420	560	700	840	980	1120	1260	1400
JAS30L	Stroke	176	352	528	704	880	1056	1232	1408	1584	1760
	L <sub>max</sub>	210	420	630	840	1050	1260	1470	1680	1890	2100
JAS35L	Stroke	176	352	528	704	880	1056	1232	1408	1584	1760
	L <sub>max</sub>	210	420	630	840	1050	1260	1470	1680	1890	2100

Remarks: Values of odd number BL (3, 5, 7, ...) can be obtained by adding two values of even number BLs on both side, then dividing the sum by two.

**(8) Reference number**

Reference numbers shall be set to individual NSK linear guide when its specifications are finalized, and it is indicated on its specification drawing.

Please specify the reference number, except design serial number, to identify the product when ordering, requiring estimates, or inquiring about specifications from NSK.

**1. Reference number for preloaded assembly**

**LS 30 1000 AL C 2 -\*\* P5 3**

Series name							
Size							Preload code (See page A188)
Rail length (mm)							Accuracy code (See Table 21)
Ball slide shape code (See page A186)							Design serial number
Material/surface treatment code (See Table 20)							Added to the reference number.
							Number of ball slides per rail

**2. Reference number for random-matching type**

**LAS 30 AL C -\*\*PCZ**

Ball slide							
Random-matching ball slide series code							Preload code
Size							T: Fine clearance. Z: Slight preload (See page A188)
Ball slide shape code (See page A186)							Accuracy code : PC
Material/surface treatment code (See Table 20)							PC: Normal grade is only available
							Design serial number
							Added to the reference number.

**L1S 30 1000 L C N -\*\* PC Z**

Rail							
Random-matching rail series code							Preload code
Size							T: Fine clearance. Z: Slight preload (See page A188)
Rail length (mm)							Accuracy code : PC
Rail shape code							PC: Normal grade is only available
Material/surface treatment code (See Table 20)							Design serial number
							Added to the reference number.
							*Butting rail specification
							N: Non-butting. L: Butting specification

\*Please consult with NSK for butting rail specification.

Reference number for assembly of random-matching ball slide and rail is the same as the coding of preloaded assembly. However, preload code is fine clearance "T" or slight preload "Z" (Refer to page A188).

**Table 20 Material/surface treatment code**

Code	Description
C	Special high carbon steel (NSK standard)
K	Stainless steel
D	Special high carbon steel with surface treatment
H	Stainless steel with surface treatment
Z	Other, special

**Table 21 Accuracy code**

Accuracy	Standard (Without NSK K1)	With NSK K1	With NSK K1 for food and medical equipment
Ultra precision grade	P3	K3	F3
Super precision grade	P4	K4	F4
High precision grade	P5	K5	F5
Precision grade	P6	K6	F6
Normal grade	PN	KN	FN
Normal grade (random-matching type)	PC	KC	FC

Note: Refer to Page A38 and A61 for NSK K1 lubrication unit.

(9) Dimensions  
 LS-CL (Medium-load type)  
 LS-AL (High-load type)

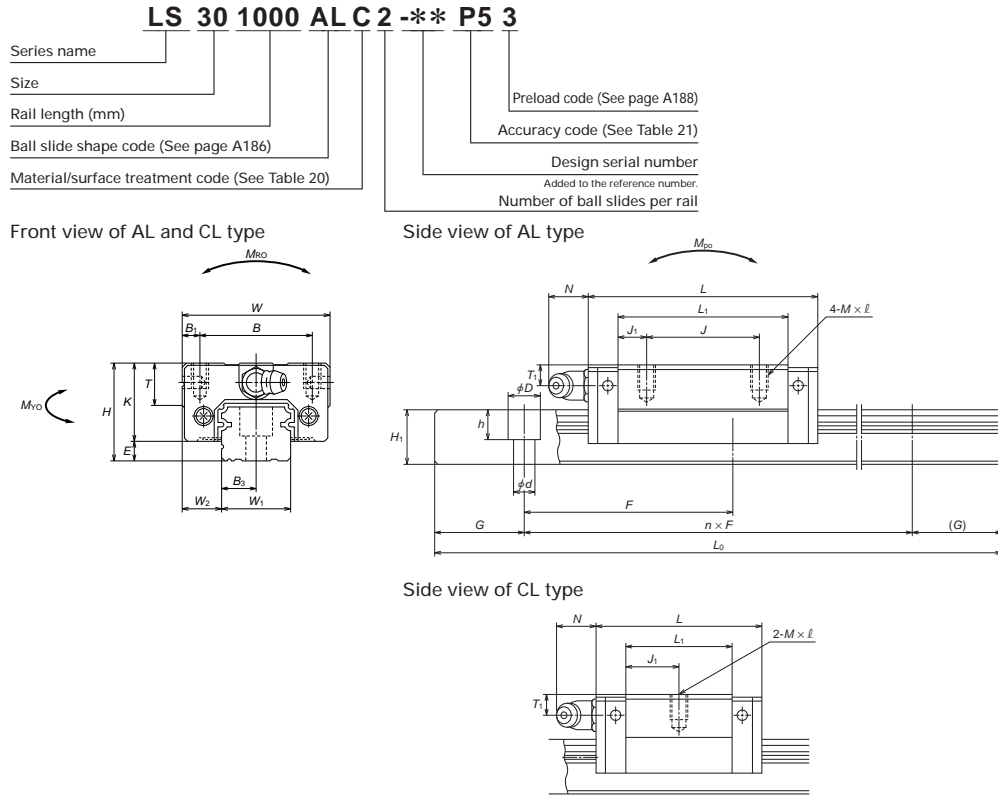

Model No.	Assembly					Ball slide										
	Height		Width	Length	Mounting hole						Grease fitting					
	H	E			B	J	M x pitch x l	B1	L1	J1	K	T	Hole size	T1	N	
LS15CL LS15AL	24	4.6	9.5	34	40.4 56.8	26	26	M4x0.7x6	4	23.6 40	11.8 7	19.4	10	phi 3	6	3
LS20CL LS20AL	28	6	11	42	47.2 65.2	32	32	M5x0.8x7	5	30 48	15 8	22	12	M6x0.75	5.5	11
LS25CL LS25AL	33	7	12.5	48	59.6 81.6	35	35	M6x1x9	6.5	38 60	19 12.5	26	12	M6x0.75	7	11
LS30CL LS30AL	42	9	16	60	67.4 96.4	40	40	M8x1.25x12	10	42 71	21 15.5	33	13	M6x0.75	8	11
LS35CL LS35AL	48	10.5	18	70	77 108	50	50	M8x1.25x12	10	49 80	24.5 15	37.5	14	M6x0.75	8.5	11

Remarks: 1) The external appearance of stainless steel ball slides differs from those of standard material ball slide.

Reference number for ball slide of random-matching type

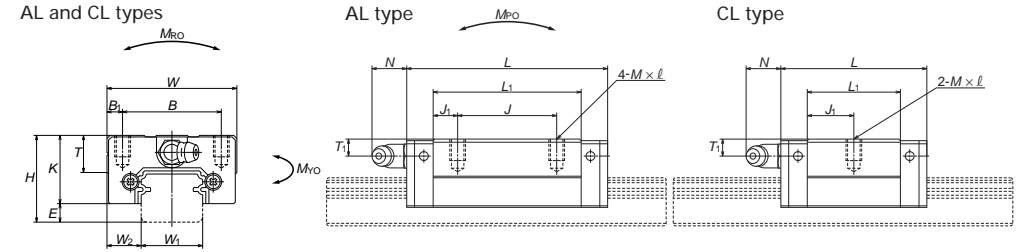
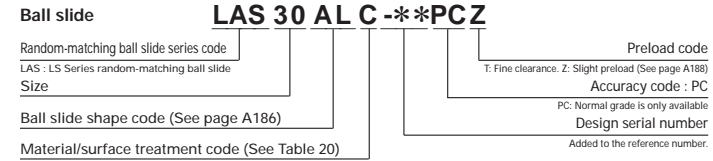

Reference number for rail of random-matching type

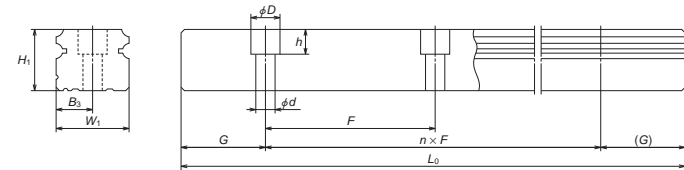
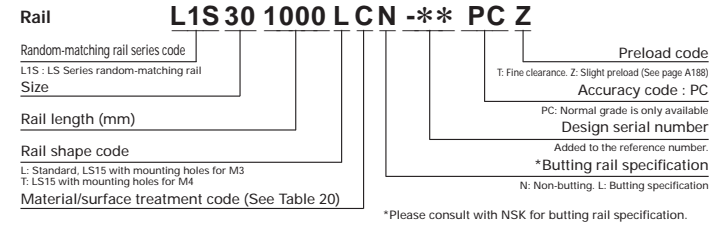

Rail										Basic load rating					Ball dia. Dw	Weight	
Width W1	Height H1	Pitch F	Mounting bolt hole d x D x h	B3	G (reference)	Max. length Lmax. ( ) for stainless	Dynamic C (N)	Static C0 (N)	Static moment Mro (N·m)	Mfo (N·m)	Mvo (N·m)	Ball slide (kg)	Rail (kg/m)				
15	12.5	60	*3.5x6x4.5 4.5x7.5x5.3	7.5	20	2000 (1700)	5400 8350	9100 16900	45.5 84.5	24.5 77	20.5 64.5	2.778	0.14 0.20	1.4			
20	15.5	60	6x9.5x8.5	10	20	3960 (3500)	7900 11700	13400 23500	91.5 160	46.5 133	39 111	3.175	0.19 0.28	2.3			
23	18	60	7x11x9	11.5	20	3960 (3500)	12700 18800	20800 36500	164 286	91 258	76 217	3.968	0.34 0.51	3.1			
28	23	80	7x11x9	14	20	4000 (3500)	18700 28800	29600 55000	282 520	139 435	116 365	4.762	0.58 0.85	4.8			
34	27.5	80	9x14x12	17	20	4000 (3500)	26000 40000	40000 74500	465 865	220 695	185 580	5.556	0.86 1.3	7.0			

2) The basic dynamic load rating is a load that furnishes 50 km rating fatigue life; it is a vertical and constant load to the ball slide mounting surface. When converting the basic dynamic load rating C to the dynamic load rating C100 for 100 km rating fatigue life, divide the C by 1.26.  
 \* Standard mounting hole of LS15 rail is for M3 bolts (Hole size: 3.5x6x4.5).  
 If you require the mounting hole for M4 bolts (Hole size: 4.5x7.5x5.3), please specify it when ordering.

LS-JL (Medium-load type)  
LS-EL (High-load type)

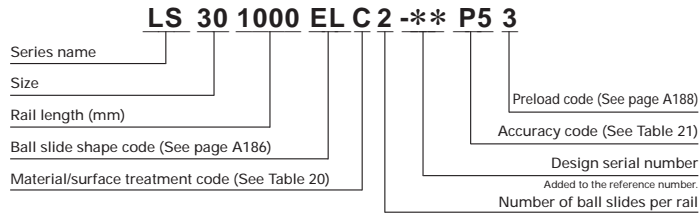

Front view of EL and JL type

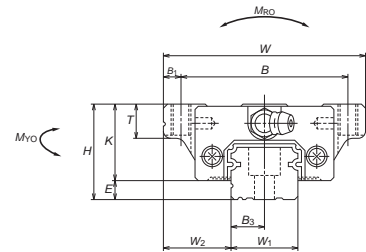

Side view of EL type

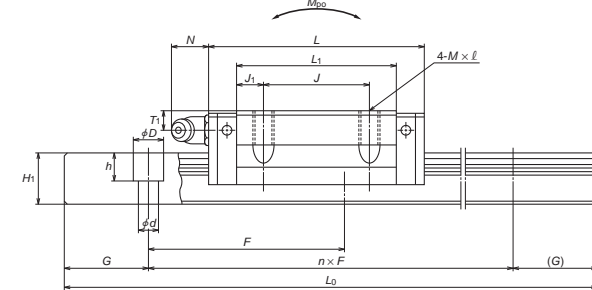

Side view of JL type

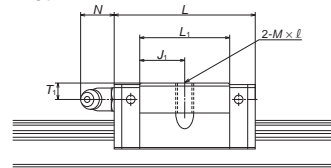

Reference number for ball slide of random-matching type

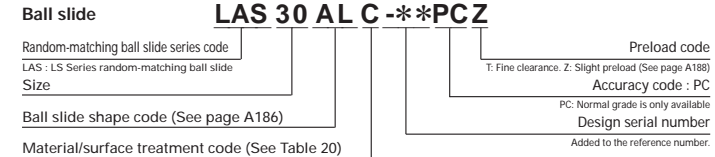

EL and JL types

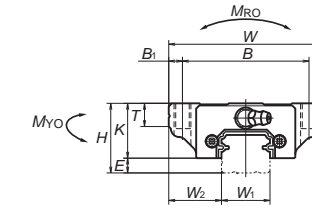

EL type

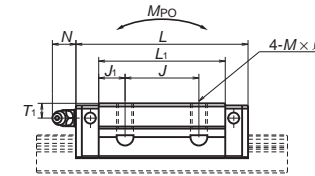

JL type

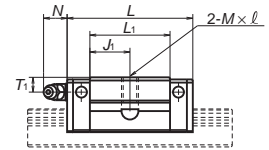

Reference number for rail of random-matching type

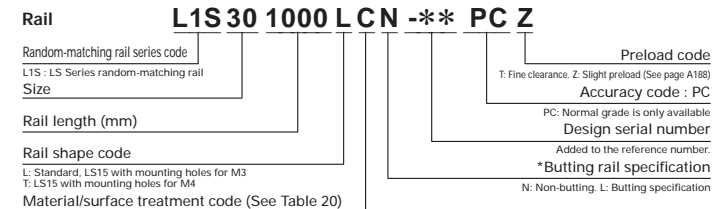

\*Please consult with NSK for butting rail specification.

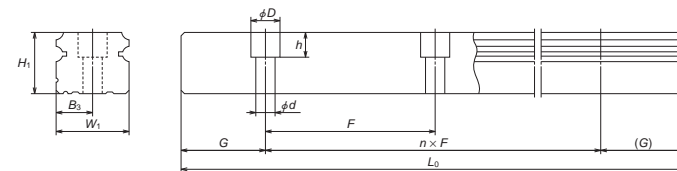

Model No.	Assembly			Ball slide											Grease fitting	
	Height	Width	Length	Mounting hole					B <sub>1</sub>	L <sub>1</sub>	J <sub>1</sub>	K	T	Hole size	T <sub>1</sub>	N
				B	J	M × pitch × l										
LS15JL LS15EL	24	4.6	18.5	52	40.4 56.8	41	26	M5×0.8×8	5.5	23.6 40	11.8 7	19.4	8	φ 3	6	3
LS20JL LS20EL	28	6	19.5	59	47.2 65.2	49	32	M6×1×10	5	30 48	15 8	22	10	M6×0.75	5.5	11
LS25JL LS25EL	33	7	25	73	59.6 81.6	60	35	M8×1.25×12	6.5	38 60	19 12.5	26	11 (12)	M6×0.75	7	11
LS30JL LS30EL	42	9	31	90	67.4 96.4	72	40	M10×1.5×18 (M10×1.5×15)	9	42 71	21 15.5	33	11 (15)	M6×0.75	8	11
LS35JL LS35EL	48	10.5	33	100	77 108	82	50	M10×1.5×20 (M10×1.5×15)	9	49 80	24.5 15	37.5	12 (15)	M6×0.75	8.5	11

Remarks: 1) The external appearance of stainless steel ball slides differs from those of standard material ball slide.  
 2) Parenthesized dimensions are for items made of stainless steel.

Unit: mm

Rail							Basic load rating					Ball dia. D <sub>w</sub>	Weight		
Width	Height	Pitch	Mounting bolt hole	B <sub>3</sub>	G	Max. length L <sub>max</sub> ( ) for stainless	Dynamic C	Static C <sub>0</sub>	Static moment				Ball slide (kg)	Rail (kg/m)	
W <sub>1</sub>	H <sub>1</sub>	F	d × D × h	B <sub>3</sub>	(reference)	(N)	(N)	M <sub>RO</sub>	M <sub>PO</sub>	M <sub>VO</sub>	(N·m)	(N·m)	(N·m)		
15	12.5	60	*3.5×6×4.5 4.5×7.5×5.3	7.5	20	2000 (1700)	5400 8350	9100 16900	45.5 84.5	24.5 77	20.5 64.5	2.778	0.17 0.26	1.4	
20	15.5	60	6×9.5×8.5	10	20	3960 (3500)	7900 11700	13400 23500	91.5 160	46.5 133	39 111	3.175	0.24 0.35	2.3	
23	18	60	7×11×9	11.5	20	3960 (3500)	12700 18800	20800 36500	164 286	91 258	76 217	3.968	0.44 0.66	3.1	
28	23	80	7×11×9	14	20	4000 (3500)	18700 28800	29600 55000	282 520	139 435	116 365	4.762	0.76 1.2	4.8	
34	27.5	80	9×14×12	17	20	4000 (3500)	26000 40000	40000 74500	465 865	220 695	185 580	5.556	1.2 1.7	7.0	

3) The basic dynamic load rating is a load that furnishes 50 km rating fatigue life; it is a vertical and constant load to the ball slide mounting surface.  
 When converting the basic dynamic load rating C to the dynamic load rating C<sub>100</sub> for 100 km rating fatigue life, divide the C by 1.26.

\* Standard mounting hole of LS15 rail is for M3 bolts (Hole size: 3.5×6×4.5).  
 If you require the mounting hole for M4 bolts (Hole size: 4.5×7.5×5.3), please specify it when ordering.

LS-KL (Medium-load type)  
LS-FL (High-load type)

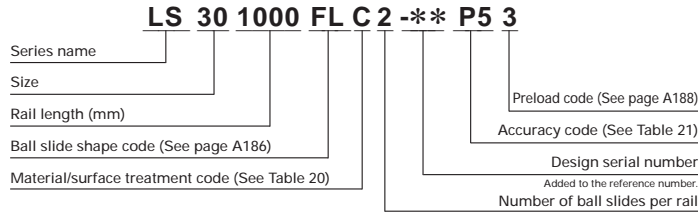

Front view of FL and KL type

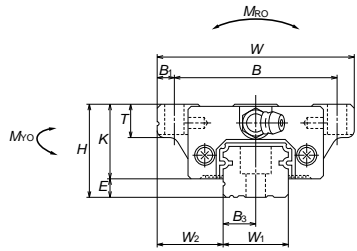

Side view of FL type

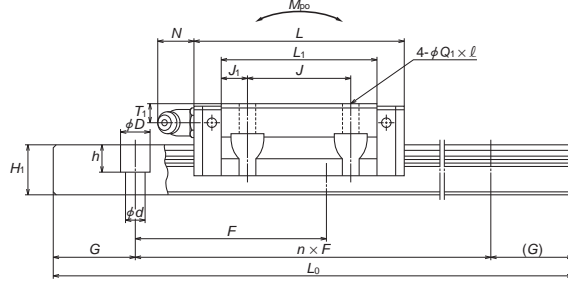

Side view of KL type

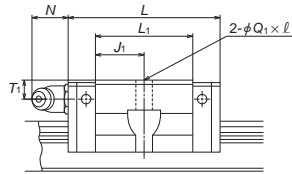

Reference number for ball slide of random-matching type

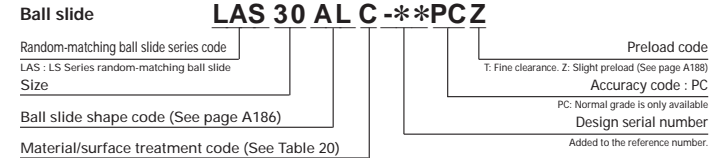

FL and KL types

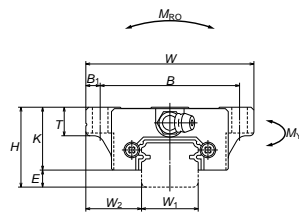

FL type

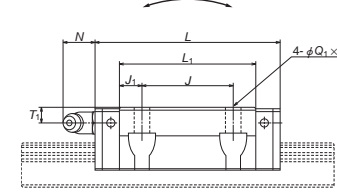

KL type

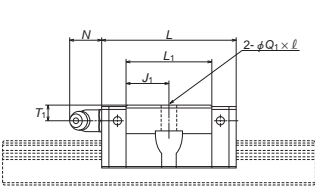

Reference number for rail of random-matching type

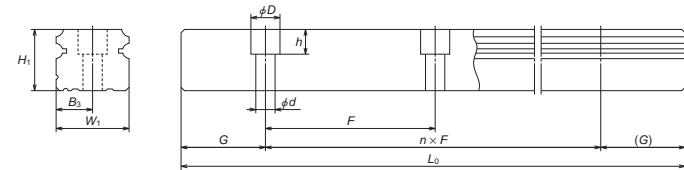
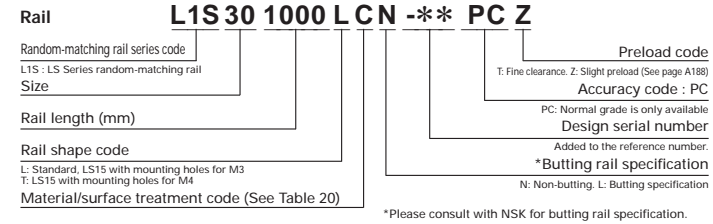

Model No.	Assembly			Ball slide											Grease fitting			
	Height H	E	W <sub>2</sub>	Width W	Length L	Mounting hole					B <sub>1</sub>	L <sub>1</sub>	J <sub>1</sub>	K	T	Hole size	T <sub>1</sub>	N
						B	J	Q <sub>1</sub> × l										
LS15KL LS15FL	24	4.6	18.5	52	40.4 56.8	41 26	—	4.5 × 7			5.5	23.6 40	11.8 7	19.4	8	φ 3	6	3
LS20KL LS20FL	28	6	19.5	59	47.2 65.2	49 32	—	5.5 × 9 (5.5 × 9.5)			5	30 48	15 8	22	10	M6 × 0.75	5.5	11
LS25KL LS25FL	33	7	25	73	59.6 81.6	60 35	—	7 × 10 (7 × 11.5)			6.5	38 60	19 12.5	26	11 (12)	M6 × 0.75	7	11
LS30KL LS30FL	42	9	31	90	67.4 96.4	72 40	—	9 × 12 (9 × 14.5)			9	42 71	21 15.5	33	11 (15)	M6 × 0.75	8	11
LS35KL LS35FL	48	10.5	33	100	77 108	82 50	—	9 × 13 (9 × 14.5)			9	49 80	24.5 15	37.5	12 (15)	M6 × 0.75	8.5	11

Remarks: 1) The external appearance of stainless steel ball slides differs from those of standard material ball slide.  
2) Parenthesized dimensions are for items made of stainless steel.

Rail							Basic load rating					Ball dia.		Weight	
Width W <sub>1</sub>	Height H <sub>1</sub>	Pitch F	Mounting bolt hole d × D × h	B <sub>3</sub>	G (reference)	Max. length L <sub>0max</sub> ( ) for stainless	Dynamic			Static		D <sub>w</sub>	Rail slide		
							C (N)	C <sub>0</sub> (N)	M <sub>RO</sub> (N·m)	M <sub>PO</sub> (N·m)	M <sub>VO</sub> (N·m)		Ball slide (kg)	Rail slide (kg/m)	
15	12.5	60	*3.5 × 6 × 4.5 4.5 × 7.5 × 5.3	7.5	20	2000 (1700)	5400 8350	9100 16900	45.5 84.5	24.5 77	20.5 64.5	2.778	0.17 0.26	1.4	
20	15.5	60	6 × 9.5 × 8.5	10	20	3960 (3500)	7900 11700	13400 23500	91.5 160	46.5 133	39 111	3.175	0.24 0.35	2.3	
23	18	60	7 × 11 × 9	11.5	20	3960 (3500)	12700 18800	20800 36500	164 286	91 258	76 217	3.968	0.44 0.66	3.1	
28	23	80	7 × 11 × 9	14	20	4000 (3500)	18700 28800	29600 55000	282 520	139 435	116 365	4.762	0.76 1.2	4.8	
34	27.5	80	9 × 14 × 12	17	20	4000 (3500)	26000 40000	40000 74500	465 865	220 695	185 580	5.556	1.2 1.7	7	

3) The basic dynamic load rating is a load that furnishes 50 km rating fatigue life; it is a vertical and constant load to the ball slide mounting surface. When converting the basic dynamic load rating C to the dynamic load rating C<sub>100</sub> for 100 km rating fatigue life, divide the C by 1.26.  
\* Standard mounting hole of LS15 rail is for M3 bolts (Hole size: 3.5 × 6 × 4.5).  
If you require the mounting hole for M4 bolts (Hole size: 4.5 × 7.5 × 5.3), please specify it when ordering.

LS-JM (Medium-load type)  
LS-EM (High-load type)

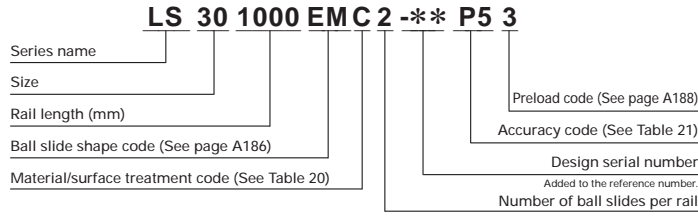

Front view of EM and JM type

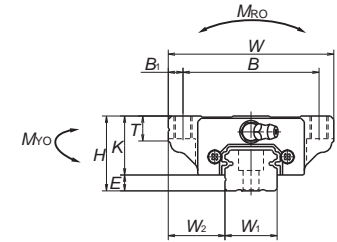

Side view of EM type

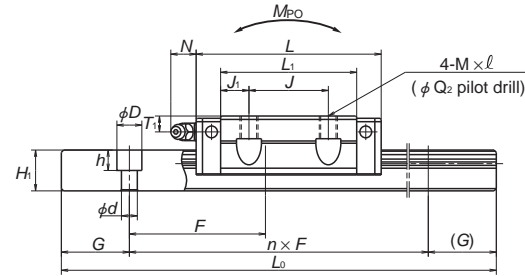

Side view of JM type

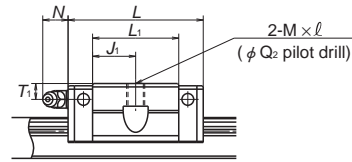

Reference number for ball slide of random-matching type

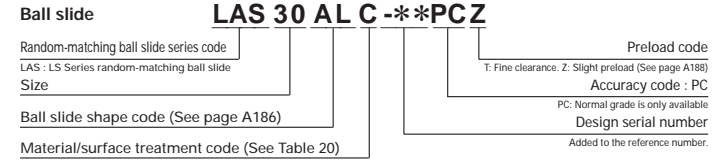

EM and JM types

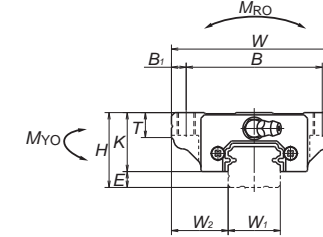

EM type

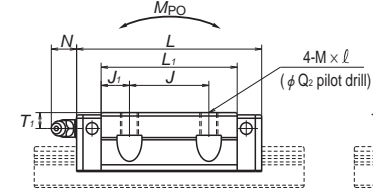

JM type

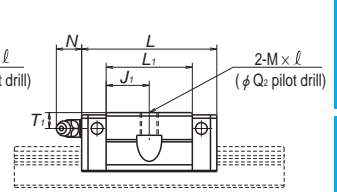

Reference number for rail of random-matching type

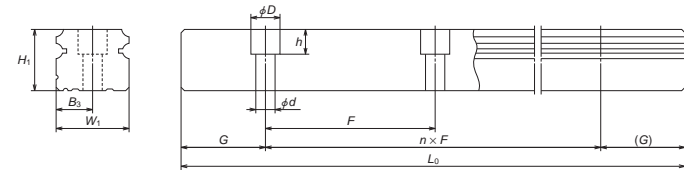
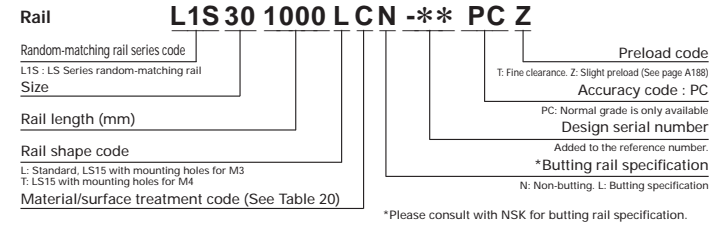

Model No.	Assembly		Ball slide														Grease fitting				
	Height	Width	Length	Mounting hole						Pitch	Pitch	Pitch	Pitch	Pitch	Pitch	Pitch	Pitch	Pitch	Hole size	T <sub>1</sub>	N
				B	J	M × pitch × l	Q <sub>2</sub>	B <sub>1</sub>	L <sub>1</sub>												
LS15JM LS15EM	24	4.6	18.5	52	40.4 56.8	41 26	—	M5×0.8×7	4.4	5.5	23.6 40	11.8 7	19.4	8	φ 3	6	3				
LS20JM LS20EM	28	6	19.5	59	47.2 65.2	49 32	—	M6×1×9 (M6×1×9.5)	5.3	5	30 48	15 8	22	10	M6×0.75	5.5	11				
LS25JM LS25EM	33	7	25	73	59.6 81.6	60 35	—	M8×1.25×10 (M8×1.25×11.5)	6.8	6.5	38 60	19 12.5	26	11 (12)	M6×0.75	7	11				
LS30JM LS30EM	42	9	31	90	67.4 96.4	72 40	—	M10×1.5×12 (M10×1.5×14.5)	8.6	9	42 71	21 15.5	33	11 (15)	M6×0.75	8	11				
LS35JM LS35EM	48	10.5	33	100	77 108	82 50	—	M10×1.5×13 (M10×1.5×14.5)	8.6	9	49 80	24.5 15	37.5	12 (15)	M6×0.75	8.5	11				

Remarks: 1) The external appearance of stainless steel ball slides differs from those of standard material ball slide.  
2) Parenthesized dimensions are for items made of stainless steel.

Rail							Basic load rating					Ball dia.	Weight	
Width	Height	Pitch	Mounting bolt hole	B <sub>3</sub>	G	Max. length L <sub>0max</sub> ( ) for stainless	Dynamic C	Static C <sub>0</sub>	Static moment			D <sub>w</sub>	Ball slide (kg)	Rail slide (kg/m)
W <sub>1</sub>	H <sub>1</sub>	F	d × D × h	B <sub>3</sub>	(reference)	( )	(N)	(N)	M <sub>RO</sub>	M <sub>PO</sub>	M <sub>VO</sub>			
15	12.5	60	*3.5×6×4.5 4.5×7.5×5.3	7.5	20	2000 (1700)	5400 8350	9100 16900	45.5 84.5	24.5 77	20.5 64.5	2.778	0.17 0.26	1.4
20	15.5	60	6×9.5×8.5	10	20	3960 (3500)	7900 11700	13400 23500	91.5 160	46.5 133	39 111	3.175	0.24 0.35	2.3
23	18	60	7×11×9	11.5	20	3960 (3500)	12700 18800	20800 36500	164 286	91 258	76 217	3.968	0.44 0.66	3.1
28	23	80	7×11×9	14	20	4000 (3500)	18700 28800	29600 55000	282 520	139 435	116 365	4.762	0.76 1.2	4.8
34	27.5	80	9×14×12	17	20	4000 (3500)	26000 40000	40000 74500	465 865	220 695	185 580	5.556	1.2 1.7	7

3) The basic dynamic load rating is a load that furnishes 50 km rating fatigue life; it is a vertical and constant load to the ball slide mounting surface. When converting the basic dynamic load rating C to the dynamic load rating C<sub>100</sub> for 100 km rating fatigue life, divide the C by 1.26.  
\* Standard mounting hole of LS15 rail is for M3 bolts (Hole size: 3.5×6×4.5).  
If you require the mounting hole for M4 bolts (Hole size: 4.5×7.5×5.3), please specify it when ordering.